



Amendment to the Public Environmental Report for the Nyrstar Port Pirie Smelter Transformation Proposal - Pre-Treatment Plant

Nyrstar Port Pirie
MAY 2022



EXECUTIVE SUMMARY

Nyrstar Port Pirie Pty Ltd (Nyrstar) is applying to vary the development approval granted for the Port Pirie Smelter redevelopment pursuant to s.115(8) of Planning, Development and Infrastructure Act 2016 (SA) (PDI Act).

The application is supported by this document titled “Amendment to the Public Environmental Report for the Nyrstar Port Pirie Smelter Transformation Proposal - Pre-Treatment Plant”. This document is presented as an amendment to the original Public Environment Report (PER) pursuant to s.114(1)) of the PDI Act, noting that a Public Environment Report is equivalent to an Environment Impact Assessment under this Act.

The primary objective of the original Port Pirie Smelter Transformation was to upgrade the smelter’s primary lead production facilities to make them more efficient and have significantly reduced lead and sulphur dioxide emissions. The Transformation will secure the facility’s long term future in Port Pirie and facilitate the next phase of emission and community blood lead reductions. The Transformation “Port Pirie Redevelopment Project” replaced the sinter plant with modern enclosed bath smelting technology i.e. a Top-Submerged Lance (TSL) furnace, installed a new sulphuric acid facility, and updated ancillary equipment. The original approval scope also included the eventual decommissioning of the sinter plant and associated acid plant at a later stage. Since the sinter plant was decommissioned in November 2019, a portion of this demolition has occurred such that the historical “sintering” process is no longer operable.

While anticipated reductions of sulphur dioxide have been achieved, further investments are required to achieve the full reduction to lead in air concentrations. An important contributor that continues to be addressed is the outdoor storage of lead bearing materials.

Under the current application, Nyrstar proposes to install a new “Pre-Treatment Plant” that will re-purpose some of the now redundant sinter plant equipment to create a new process to pre-treat material for use in the blast furnace. This new Pre-Treatment process will enable Nyrstar to process feed materials in parallel with the TSL furnace and maximise the use of the full Blast Furnace capacity in order to fast-track removal of secondary feed stockpiles on site within a 3 – 6 year timeframe. Without this project, the removal of these stockpiles is estimated to be 20+ years. The stockpiles accumulated when Nyrstar zinc smelters continued to generate secondary feed materials during the commissioning and ramp-up of the TSL Furnace. The TSL Furnace is still ramping up to full capacity. As such, the TSL Furnace is processing current arisings of secondary feed materials and would take an extended period of time to treat the backlog without the benefit of the Pre-Treatment Plant. Thus, operation of the Pre-Treatment Plant will accelerate depletion of external stockpiles and deliver associated lead in air improvements sooner.

The project benefits include improved environmental and economic outcomes. It will further enable Nyrstar’s continuing efforts to reduce emissions, bringing forward a sustainable improvement to air quality once materials are no longer stored outside. It is noted that

EXECUTIVE SUMMARY

this project is also part of an overarching lead in air reduction strategy that includes various projects and initiatives that will continue to improve air quality in Port Pirie over time, including a proposed Product Recycling Facility, covering stockpiles and erecting domes over material handling activities. These efforts also align with the South Australian Government's strategic priority to improve health outcomes for children, particularly in the first five years of life. The new process will aid in securing both a short- and long-term sustainable future for operations in Port Pirie, provide up to 40 additional local jobs and will aid Nyrstar's continued contribution to the economic development of Port Pirie and South Australia.

Nyrstar has demonstrated ongoing commitment to reducing lead emissions to air and improving the health of the community, thus delivering a sustainable future for the facility, Port Pirie and the wider region.

The key environmental impact from the project will be on air quality. Overall, the project is anticipated to deliver a significant long-term sustainable reduction in emissions (up to 28% for lead) from the project baseline of actual performance at 31 December 2020 (i.e. the relevant comparison year at the time the project was originally conceived). While there are anticipated to be some ongoing emissions during the plant operation, modelling has demonstrated the ongoing all-of-site emission reduction work mitigates these emissions.

Additionally, Nyrstar has been undertaking an EPA approved trial to understand and mitigate the potential impacts. As a result of the trial, a number of additional improvement initiatives have been identified and incorporated into the project design to minimise Lead and dust emissions to air that may result from operating the Pre-Treatment Plant and reclaiming the stockpiled materials.

A further sustainability platform for the proposal is its contribution to South Australia's circular economy by processing secondary feed materials (waste) from Zinc smelters to manufacture new products (Lead metal and Zinc Oxide fume). A circular economy refers to



EXECUTIVE SUMMARY

an economy that uses a systems-focused approach and involves industrial processes and economic activities that are restorative or regenerative by design, enable resources used in such processes and activities to maintain their highest value for as long as possible, and aim for the elimination of waste through the superior design of materials, products, and systems (including business models). It is a change to the model in which resources are mined, made into products, and then become waste. A circular economy reduces material use, redesigns materials to be less resource intensive, and recaptures “waste” as a resource to manufacture new materials and products.

The Nyrstar Port Pirie facility is uniquely placed in Australia to maximise resource use efficiency of the Australian non-ferrous metals industry and increase Australia’s economic benefits by capturing more value from raw materials mined in Australia. The Pre-treatment Plant will provide an enhanced capacity to treat residues and by-products from other non-ferrous metals plants (such as Nyrstar’s linked zinc smelter in Hobart). These materials can be considered ‘pre-consumer’ recycled feed materials. As such, the project has the ability to greatly increase the proportion of recovered/ recycled content in end products – including lead metal, zinc oxide, copper, gold and silver products, etc.





CONTENTS

Amendment to the Public Environmental Report for the Nyrstar Port Pirie Smelter Transformation Proposal - Pre-Treatment Plant.

Executive Summary	2
1. Introduction	9
1.1 Original Major Development Approval process	10
1.2 The Major Development Approval Variation Process	10
2. Description of Proposed Variation	11
2.1 Original Proposal	11
2.2 Proposed Variation	14
2.3 Project Benefits	15
3. Plant Operation and Infrastructure Modifications	26
3.1 Plant Operation	26
3.2 Infrastructure Modifications	28
4. Management of Potential Environmental Impacts	31
5. Environmental Performance for Current Trial to Date	36
6. Air Dispersion Modelling of Emission Scenarios	42
7. Variation from the 2013 Public Environment Report	50
8. Conclusion	52
9. Glossary of Technical Terms	53
Volume II - Amendment to the Public Environmental Report for the Nyrstar Port Pirie Smelter Transformation Proposal - Pre-Treatment Plant	54

CONTENTS

FIGURES

Figure 1: Overall Site Process Flow Diagram	17
Figure 2: Pre-Treatment Plant Process Flow Diagram	20
Figure 3: Current Feed System Layout	21
Figure 4: Final Layout	22
Figure 5: Nyrstar projects for recycled materials (secondary feeds) and greenhouse emissions reduction	24
Figure 6: Pre-Treatment Plant product on the Main Machine strand	26
Figure 7: Concrete Beton Blocks to be utilised for Building bunkers	30
Figure 8: Polar Plots of Metals in Air Analyser (MIAA) Lead (Pb) ng/m³ mean values during Pre-Treatment 'Off' and 'On'	38
Figure 9: Polar Plot of Ellen Street (EST) dust (PM10 real-time) ug/m³ mean values during Pre-Treatment 'Off' and 'On'	39
Figure 10: Predicted Lead monthly average concentration	46
Figure 11: Predicted absolute and percentage difference - lead	48

TABLES

Table 1: Differences between the Sintering Plant and Pre-Treatment processes	27
Table 2: Feed materials for the Pre-Treatment Plant	33
Table 3: Potential environmental impacts and control measures	34
Table 4: Summary Statistics for northerly wind during Pre-Treatment 'Off' and 'On'	37
Table 5: Current status and expected completion dates for improvement projects	40
Table 6: Pre-Treatment Plant Emission Scenarios (with estimated annualised total site emissions)	43
Table 7: Comparison of Pre-Treatment Plant Lead Emission Scenarios with the Public Environment Report (PER)	44





1. Introduction

Nyrstar Port Pirie Pty Ltd (Nyrstar) is applying to vary the current development approval granted for the Port Pirie Smelter Transformation. Under the current application, Nyrstar proposes to install a new “Pre-Treatment Plant” that will re-purpose some of the now redundant sinter plant equipment to create a new process to pre-treat material for use in the blast furnace. This new Pre-Treatment process will enable Nyrstar to process feed materials in parallel with the Top-Submerged Lance (TSL) furnace and maximise the use of the full Blast Furnace capacity in order to fast-track removal of primarily secondary feed stockpiles on site within a 3 – 6 year timeframe. Without this project, the removal of these stockpiles is estimated to be 20+ years.

1. INTRODUCTION

The stockpiles accumulated when Nyrstar zinc smelters continued to generate secondary feed materials during the commissioning and ramp-up of the TSL furnace. The TSL furnace is still ramping up to full capacity as further improvements are made to operating parameters and equipment reliability. As such, the TSL Furnace is processing current arisings of secondary feed materials and it would take an extended period of time to treat the backlog without the benefit of the Pre-Treatment Plant. Thus, operation of the Pre-Treatment Plant, in parallel with the TSL furnace, will accelerate depletion of the stockpiles and deliver associated lead in air improvements sooner. The Blast Furnace has capacity to receive feedstock from both plants and will operate more efficiently as a result.

1.1 Original Major Development Approval Process

The proposed Transformation was declared a Major Development requiring approval under Section 46C of the *Development Act 1993*. A Public Environment Report was developed in accordance with the *Guidelines for the preparation of a Public Environmental Report: Port Pirie Smelter Transformation (Mid North) (Guidelines)* issued by the South Australian Development Assessment Commission in May 2013. The Guidelines set out the matters requiring investigation and evaluation with regard to the Transformation. The Public Environment Report (PER) provided a framework for the government, industry and community to make informed decisions about the environmental, social and economic effects of the proposed Transformation.

A PER is equivalent to an Environment Impact Assessment under the current Planning, Development and Infrastructure Act 2016 (SA) (PDI Act) which was assented to on 17 April 2017. The development approval for the Port Pirie Smelter Transformation was subsequently granted. A number of minor variations to the development authorisation have previously been approved for: relocation of the oxygen plant (on 2/4/15); modifications to the design of the TSL furnace building (on 6/8/15); a new Paragoethite and Lead Sulphate leach concentrate storage pad (on 28/3/19), and; a briquetting plant (on 18/2/22).

1.2 The Major Development Approval Variation Process

Nyrstar Port Pirie Pty Ltd (Nyrstar) is applying to vary the current development authorisation (dated 18 February 2022) for the Port Pirie Smelter Transformation pursuant to s.115(8) of Planning, Development and Infrastructure Act 2016 (SA) which was assented to on 17 April 2017 and remains in effect at the time of writing. The application is supported by this document titled “Amendment to the Public Environmental Report for the Nyrstar Port Pirie Smelter Transformation Proposal - Pre-Treatment Plant”. This document is presented as an amendment to the original Public Environment Report (PER) pursuant to s.114(1) of the PDI Act, noting that a Public Environment Report is equivalent to an Environment Impact Assessment under the current Act.

2 DESCRIPTION OF PROPOSED VARIATION

2.1 Original Proposal

The primary objective of the original Port Pirie Smelter Transformation was to upgrade the smelter's primary lead production facilities to make them more efficient and have significantly reduced lead and sulphur dioxide emissions. The Transformation will secure the facility's long term future in Port Pirie and facilitate the next phase of emission and community blood lead reductions. The Transformation or "Port Pirie Redevelopment Project" sought to replace the sinter plant process with modern enclosed bath smelting technology i.e. a Top-Submerged Lance (TSL) furnace, installed a new sulphuric acid facility, and updated ancillary equipment.

The original approval scope also included eventual demolition of the sinter plant and associated acid plant at a later stage. A portion of this demolition has occurred such that the historical "sintering" process is no longer operable.

While anticipated reductions of sulphur dioxide have been achieved further investments are required to achieve the full reduction to lead in air concentrations. An important contributor that continues to be addressed is the outdoor storage of lead bearing materials. The original PER was based on the assumption of a production rate for the new TSL furnace that has not yet been achieved. As a result of the slower than anticipated ramp up, the volume of stockpiled material on site has increased since the original Development Approval. Although this increase was not envisaged, the original PER also acknowledged the need to continually investigate opportunities for recovery and reuse of lead-bearing materials in addition to the proposed Transformation changes. The reduction of outdoor storage of stockpiled materials will enable further elimination of sources for wind mobilisation and vehicle tracking of lead-bearing materials.

The original proposal included an expansion of the Co-Treatment Shed along the eastern boundary of the site to enable material handling operations in the Pit to be relocated under cover.



2. DESCRIPTION OF PROPOSED VARIATION

The Pre-Treatment Plant will utilise a travelling grate strand that is designed to accept high temperature material. The goal of the process is to remove chemically bound water while retaining sulphur in the dried material. This material will then be a supplementary feed for the blast furnace to ensure stable operation while providing a valuable sulphur source for the blast furnace. The plant will operate 24-hours per day and seven-days per week. The location of the proposed plant is shown in Attachment A. Drawings of the proposed plant layout are included in Attachment B.

BENEFITS

Improved emission stability from a Blast Furnace operating at optimal rate with consequent lower emissions of lead-in-air

Consumption of an additional 600 tonnes/ day of secondary feed materials which would reduce stockpiled volumes by an additional 146,000 tonnes per year allowing quicker depletion of stockpiles decreasing LIA impact from stockpiles

lower emissions

DIAGRAMS

A process flow diagram is provided in Figure 1 and a process flow diagram from the Pre-Treatment Plant is provided in Figure 2. The current layout is shown in Figure 3 and the final feed system arrangement is shown in Figure 4. The proposed implementation strategy is for the Pre-treatment Plant to begin operation in the current layout set up for the plant trials, allowing it continue to operate while incremental modifications are made until the final layout is achieved. The number and configuration of the Feed Hoppers within the shed shown in the final layout (Figure 4) is indicative and may change, based on operational requirements.

146,000t

BENEFITS

Contributing to additional flow-on economic activity in the area, including local businesses that supply Nyrstar

Employment opportunity for 40+ people, further improving the community employment rate

40+

2. DESCRIPTION OF PROPOSED VARIATION

2.2 Proposed Variation

Under the current application, Nyrstar is seeking to install a new “Pre-Treatment Plant” that will re-purpose some of the now redundant sinter plant equipment to create a new process to pre-treat material for use in the blast furnace. This new Pre-Treatment process will enable Nyrstar to process feed materials in parallel to the TSL furnace and maximise the use of the full Blast Furnace capacity in order to fast-track removal of primarily the leach product stockpiles on site within a 3 – 6 year timeframe.

Sand-like feedstock material (such as Paragoethite, containing Lead Sulphates and Zinc Sulphates) is loaded onto a conveyor / strand with fuel (coke fines) that passes through an oven that heats the material to remove moisture and fuse the material into gravel sized lumps. This process converts the material into a drier and more consistent feedstock for the blast furnace, which will increase its efficiency and reduce emissions.

The Pre-Treatment Plant will only be operated to accelerate the processing of accumulated secondary feed stockpiles. The Pre-Treatment Plant will not operate when stockpile backlogs have been consumed and the TSL furnace can process leach products at a rate that provides sufficient feed to supply the Blast Furnace.

When the Pre-Treatment Plant ceases operation, it will be decommissioned and any redundant infrastructure demolished. The size of the stockpile storage areas will be reduced to the area required for processing current arisings of secondary feed materials.

A process flow diagram is provided in **Figure 1** and a process flow diagram from the Pre-Treatment Plant is provided in **Figure 2**. The current layout is shown in **Figure 3** and the final feed system arrangement is shown in **Figure 4**. The proposed implementation strategy is for the Pre-treatment Plant to begin operation in the current layout set up for the plant trials, allowing it to continue to operate while incremental modifications are made until the final layout is achieved. The number and configuration of the Feed Hoppers within the shed shown in the final layout (Figure 4) is indicative and may change, based on operational requirements.

The 2013 Transformation proposal included a Co-Treatment Shed Expansion along the eastern site boundary. It is proposed to replace this with a Product Recycling Facility located adjacent to the northern wall of the Co-Treatment Shed. The Product Recycling Facility will be used to enclose blending and screening of metal bearing materials. The building will be able to feed directly into the Slag Fuming Plant, via enclosed conveyors.

2 DESCRIPTION OF PROPOSED VARIATION

2.3 Project Benefits

The project benefits include improved environmental and economic outcomes. It will further enable Nyrstar's continuing efforts to reduce emissions, bringing forward a sustainable improvement to air quality once materials are no longer stored outside. It is noted that the Pre-Treatment Plant is part of the overarching lead in air reduction strategy that includes various projects and initiatives that will continue to improve air quality in Port Pirie over time, including the Product Recycling Facility, covering stockpiles and erecting domes over material handling activities. These efforts also align with the South Australian Government's strategic priority to improve health outcomes for children, particularly in the first five years of life.

Environmental Benefits

Nyrstar is committed to reducing lead emissions to air and improving the health of the community, thus delivering a sustainable future for the facility, Port Pirie and the wider region. Figure 5 provides some context of the Pre-Treatment Plant with other Nyrstar initiatives.

The key environmental impact from the project will be on air quality. Overall, the project is anticipated to deliver a significant long-term sustainable reduction in emissions (up to 28% for lead) from the project baseline of actual performance at 31 December 2020 (i.e. the relevant comparison year at the time the project was originally conceived). The estimated reduction in Lead emissions is based on the difference between emission scenarios 2 and 1B in Table 6. Scenario 2 represents the current operation and scenario 1B represents emissions when the Pre-Treatment plant has finished operating and the leach product stockpiles have been removed. It is expected that scenario 1B will be achieved in three to six years. While there are anticipated to be some ongoing emissions during the plant operation, modelling has demonstrated the ongoing all-of-site emission reduction work mitigates these emissions.

Additionally, Nyrstar has been undertaking an EPA approved trial to understand



2. DESCRIPTION OF PROPOSED VARIATION

and mitigate the potential impacts. As a result of the trial, a number of additional improvement initiatives have been identified and incorporated into the project design to minimise Lead and dust emissions to air that may result from operating the Pre-Treatment Plant and reclaiming the stockpiled materials.

A further sustainability platform for the proposal is its contribution to South Australia's circular economy by processing secondary feed materials (waste) from Zinc smelters to manufacture new products (Lead metal and Zinc Oxide fume). A circular economy refers to an economy that uses a systems-focused approach and involves industrial processes and economic activities that are restorative or regenerative by design, enable resources used in such processes and activities to maintain their highest value for as long as possible, and aim for the elimination of waste through the superior design of materials, products, and systems (including business models). It is a change to the model in which resources are mined, made into products, and then become waste. A circular economy reduces material use, redesigns materials to be less resource intensive, and recaptures "waste" as a resource to manufacture new materials and products.

Economic Benefits

The new process will aid in securing both a short- and long-term sustainable future for operations in Port Pirie, provide up to 40 additional local jobs and will aid Nyrstar's continued contribution to the economic development of Port Pirie and South Australia. The Nyrstar Port Pirie facility is uniquely placed in Australia to maximise resource use efficiency of Australian non-ferrous metals mining output. The Pre-treatment Plant will provide an enhanced capacity to treat residues and by-products from other non-ferrous metals plants (such as Nyrstar's linked zinc smelter in Hobart). These materials can be considered 'pre-consumer' recycled feed materials. As such, the project has the ability to greatly increase the proportion of recovered/recycled content in end products – including lead metal, zinc oxide, copper, gold and silver products, etc.





PORT PIRIE SMELTER Process Flow Diagram

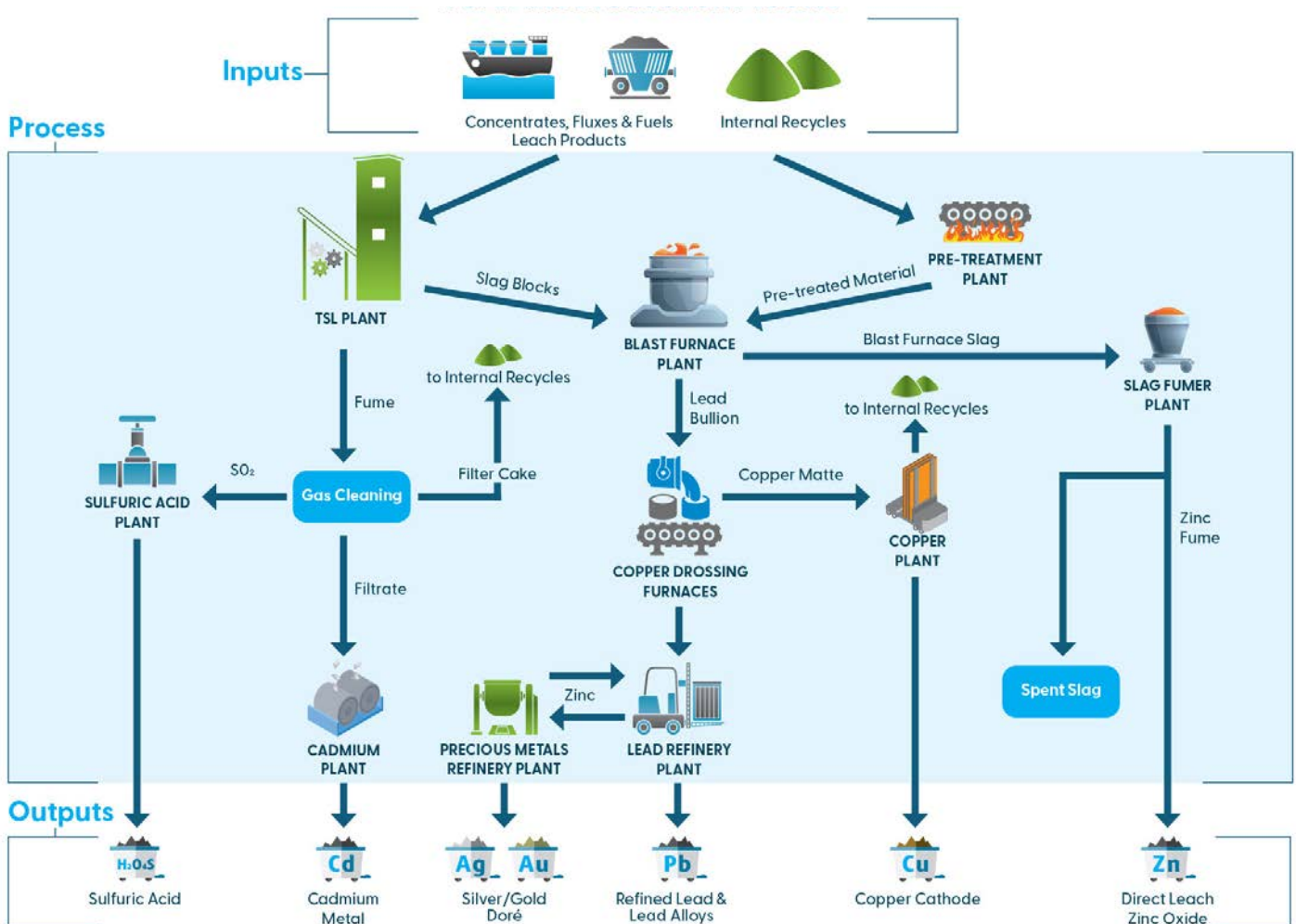

Figure 1. Overall Site Process Flow Diagram

PRE-TREATMENT PLANT Process Flow Diagram

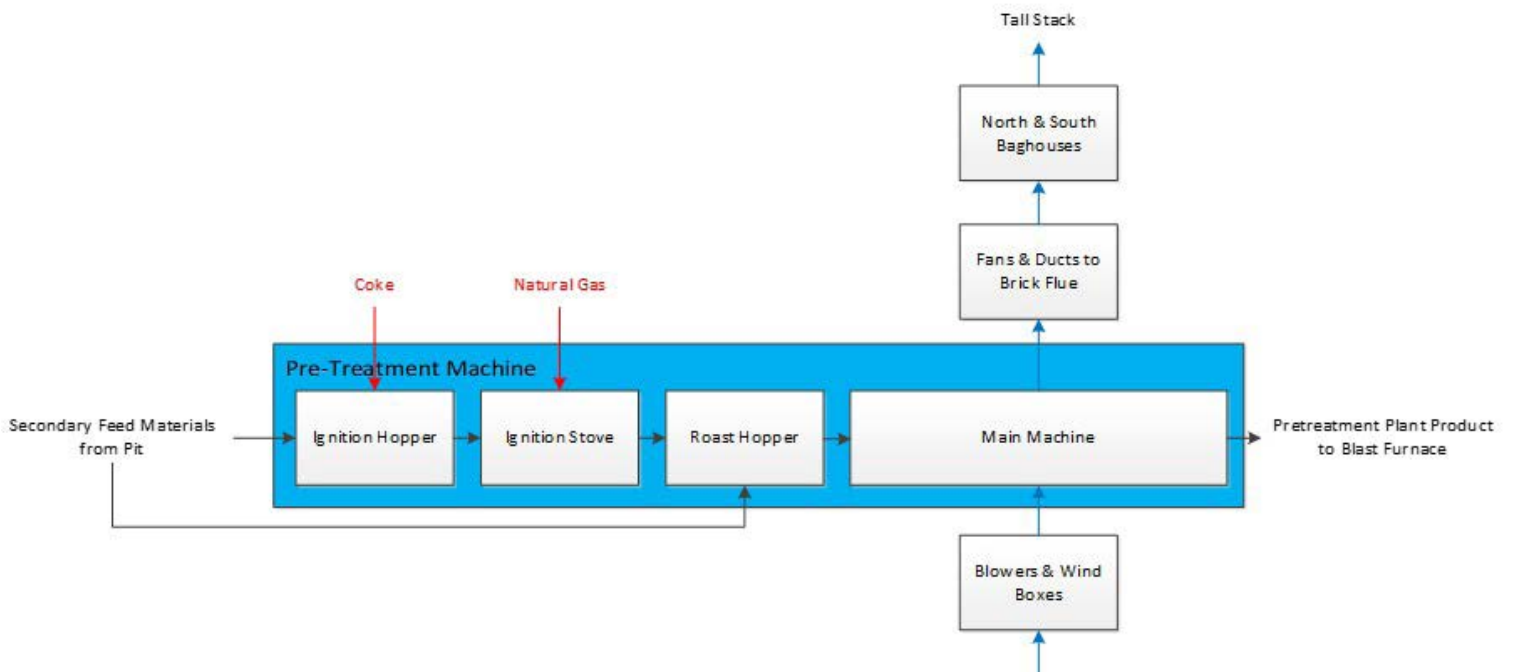

Figure 2. Pre-Treatment Plant Process Flow Diagram

Current Layout

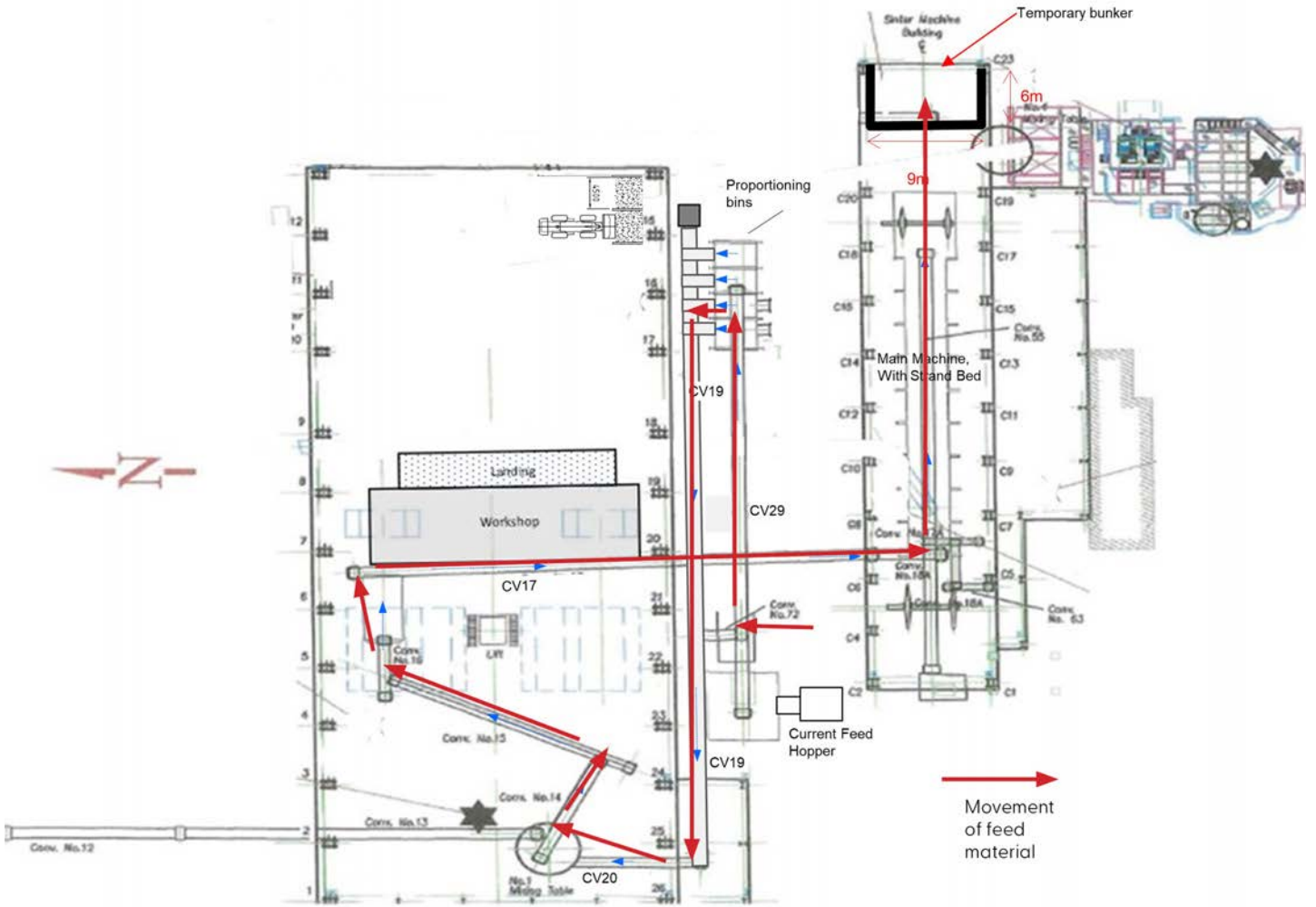

Figure 3. Current Plant Layout

Final Layout

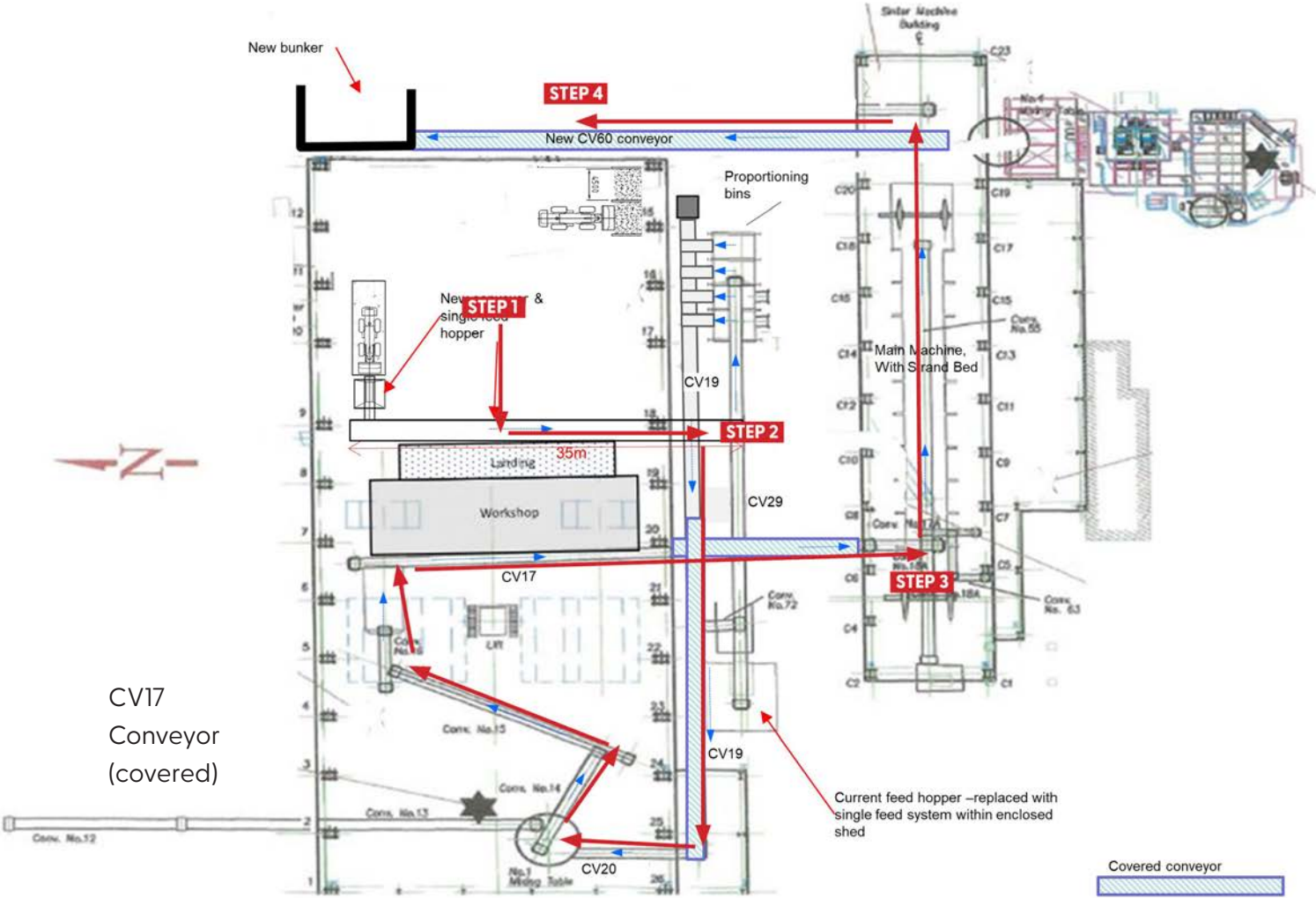

Figure 4. Final Plant Layout





Recycling and the circular economy / Emission reductions / Low-carbon future

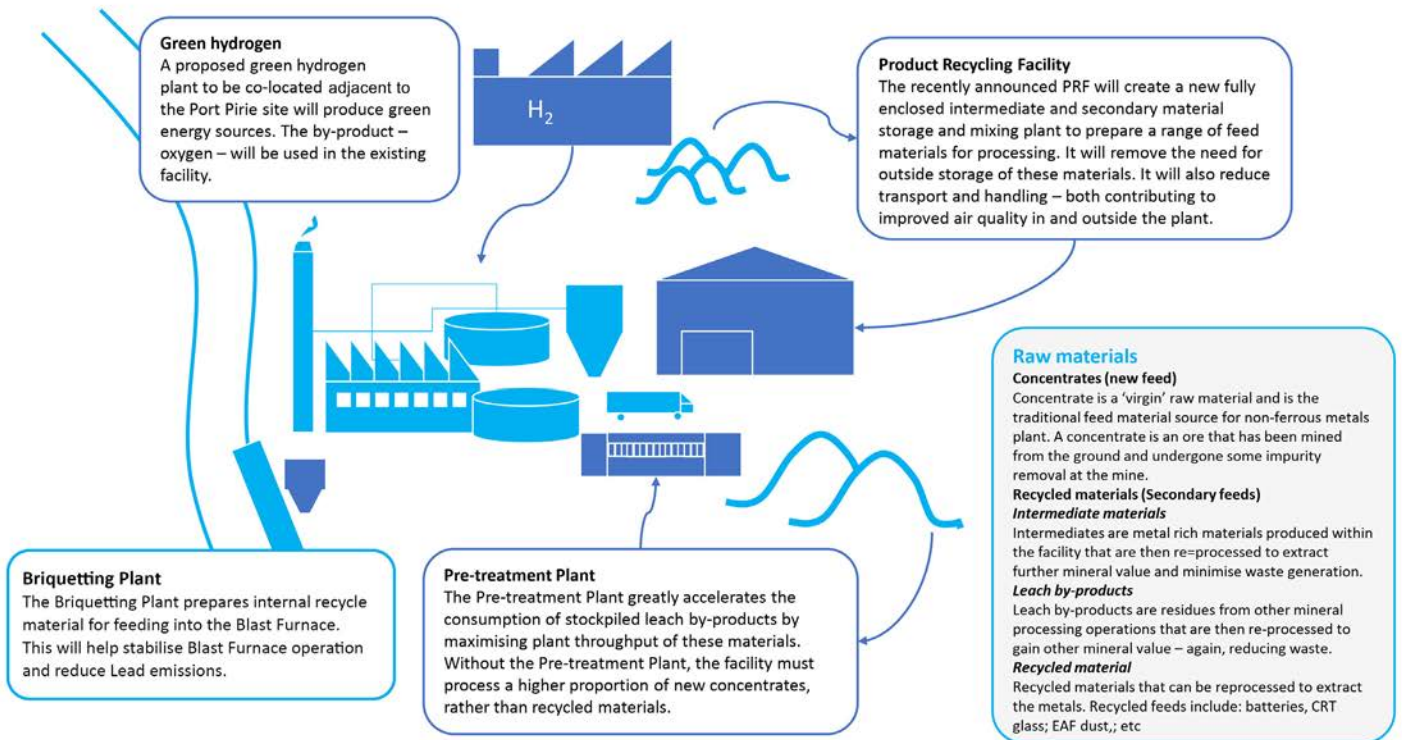

Figure 5. (above) Nyrstar projects for recycled materials (secondary feeds) and greenhouse emissions reduction

Our goal is to

**REDUCE OUR EMISSIONS
BY 30% BY 2023.**

Think efficiency. Get into the **#GreenZone**

RECYCLING AND THE CIRCULAR ECONOMY

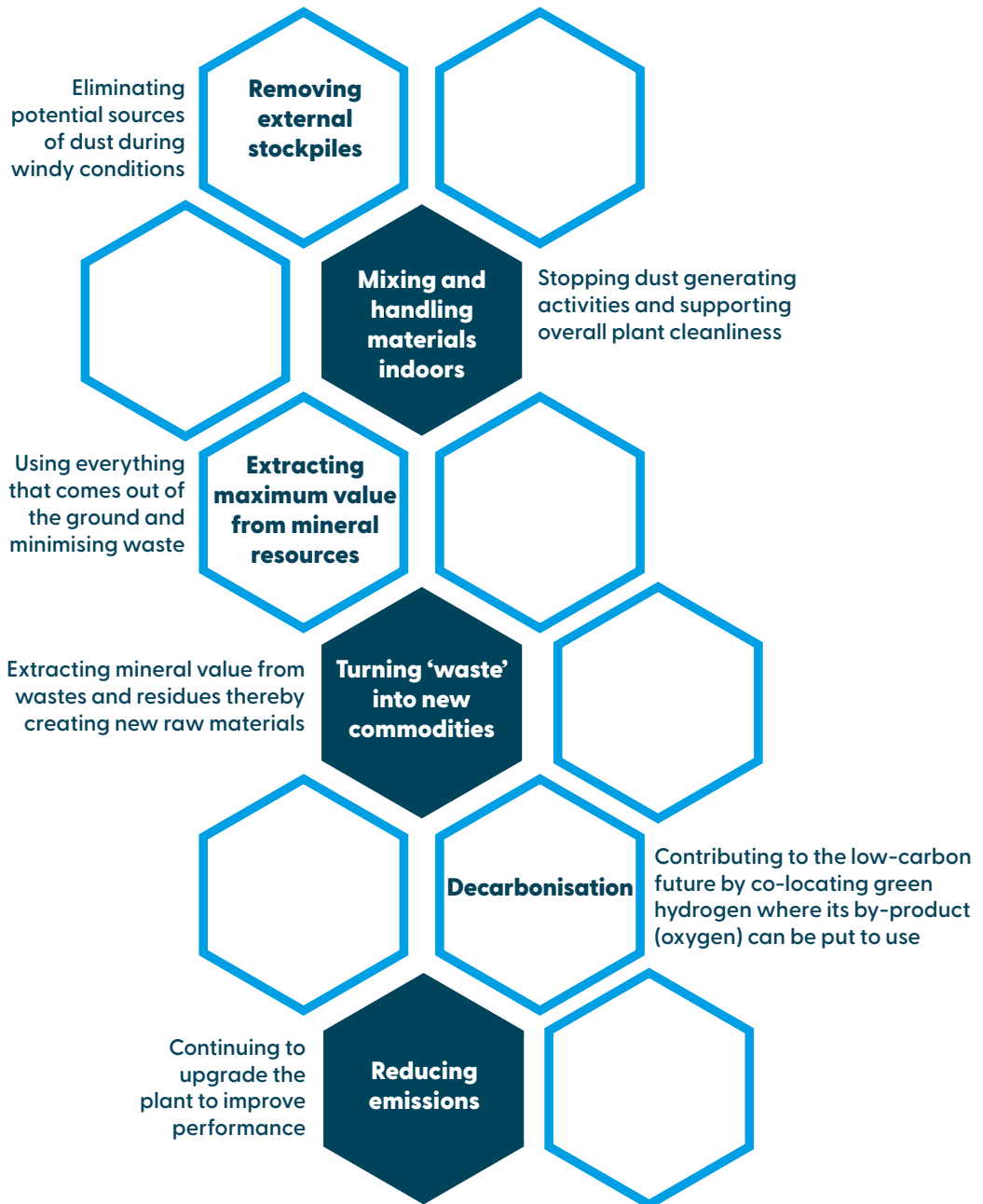

3. PLANT OPERATION AND INFRASTRUCTURE MODIFICATIONS

3.1 Plant Operation

The plant operation will include the following material handling and processing steps:

1. Feed materials nominated for treatment will be loaded onto a truck by a front-end loader, then delivered to a hopper and transferred into intermediate storage bins. The material is not expected to be dusty due to their moisture content, and dust suppressions sprays are installed for use if visible dust is observed;
2. The intermediate bins will feed onto #19 conveyor, which transfers the feed material into the plant. The #19 conveyor has been partially enclosed at the hopper end for approximately 50% of its length (refer Figure 3). It is proposed to streamline this step by constructing a new feed system in the future (refer Figure 4);
3. The Main Machine strand, where heating of the material occurs (refer Figure 2). The travelling grate strand consists of metal trolleys that move the material along while it is heated. The bed is draughted to the north & south baghouses which remove particulates, before the gas is discharged via the Tall Stack. The bed is heated using coke. The coke is ignited by a natural gas burner;
4. The treated feed material will be dropped into a bunker at the tip-end of the strand. The bunker has a hood and is draughted; and
5. The treated feed material will be transported to the Blast Furnace feed hoppers located in the vicinity.

The operation of the Pre-Treatment Plant will streamline vehicle movements across site because secondary feed materials could be consumed upon arrival, rather than transported to the stockpiles for recovery at a later stage. The operation of the TSL furnace and the Pre-Treatment Plant will be balanced to optimise site performance by providing consistent feed to the blast furnace.



Figure 6. (above) Pre-treatment Plant product on the Main Machine strand

3. PLANT OPERATION AND INFRASTRUCTURE MODIFICATIONS

The leach products fed to the Pre-treatment Plant contain predominately sulphates (both Lead and zinc). This contrasts with the lead sulphides that were fed to the strand in the former operation (refer table 1). Lead and zinc sulphates only begin to decompose at temperatures significantly above 800oC. The maximum operating temperature of the Main machine strand will be in the range of 700oC to 800oC. At these temperatures, the chemically bound water will be liberated without converting the sulphates to sulphur dioxide gas.

Removing the chemically-bound water produces a feed suitable for the Blast Furnace by decreasing the fuel required per tonne of feed and increasing the proportion of metal-bearing material in the feed. Within the proposed operating temperature range, the Pre-treatment Plant fuses the feed materials to form lumps. Converting the feed to lumps allows a greater amount to be fed to the Blast Furnace because it has limited capacity to process fine materials.

The Pre-Treatment Plant operation is oxidising and there is some potential for lead oxide to form. However, lead oxide does not melt until temperatures approaching 900oC. The Blast Furnace is exclusively a reduction process. It operates at higher temperatures, more than 1,100oC. These operating conditions enable it to decompose the lead and zinc sulphates and reduce lead oxide to lead metal.

Table 1. Differences between the Sintering Plant and Pre-Treatment processes

Parameter	Sintering Plant	Pre-Treatment Plant
Feed material:	Lead Sulphides, Lead and Zinc Sulphates	Lead and Zinc Sulphates
Feed rate:	84 tonnes per hour of new feed, plus 86 tonnes per hour of returns (recycle)	50 tonnes per hour
Fuel:	Ignition layer of coke fines (lit by gas burners). Exothermic combustion of Lead Sulphides	Coke fines (lit by gas burners)
Windbox (air) flowrate:	High	Low
Off-gas volume generated	High	Low
Acid Plant Required:	Yes	No
Comminution and returns (recycle) circuit:	Yes	No
Product produced:	Lead oxide fused into lumps	Lead and Zinc Sulphates fused into lumps

3.2 INFRASTRUCTURE MODIFICATIONS

The scope of work will include relocation of services, removal of some sections of the old plant, refurbishment of existing equipment and installation of new equipment or facilities. An aerial photo showing the project site is included in Attachment A.

Certain equipment within the footprint of the historical sinter plant will be removed to optimise operation of the plant as the Pre-Treatment Facility. This will allow improved access and hygiene within the repurposed plant. Nyrstar will remove some of the redundant structure/equipment at the “tip end” of the main machine and in other sections of the materials handling circuit as follows:

- Conveyor CV60 tail end (15m length of incline conveyor rising from 1m up to 6m) – this involves installing new structural members in order to strengthen existing structure;
- Removal of #3 vibrator (Width x Length x Height: 2m x 5m x 2m) – this involves sliding the existing vibrator to the north;
- Removal of conveyors CV66 (20m long incline from ground up to 8m) & CV56 (approx. 50m long);
- Remove conveyor CV60/61 including transfer section per item 1 (15m long, incline from 1m to 6m above ground level);
- Remove primary and secondary rolls, and “WhirlWet” scrubbers (7m diameter x 4m high each x 3);
- Remove redundant concrete “archways” (i.e. concrete supports for previous equipment);
- Remove redundant acid plant gas duct from Pre-Treatment Plant strand (main machine) through the Dwight & Lloyd (D&L) Building (2.5m diameter x approx. 70m); and
- Removal of the intermediate bins and section of conveyor CV29 once a new feed system has been commissioned.

3.2 INFRASTRUCTURE MODIFICATIONS

The new equipment and facilities to be installed are all within the existing footprint of the existing Dwight & Lloyd (D&L) and Main Machine buildings, this includes:

1. A new portable feeder for coke fines to be fed onto the existing conveyor CV19 (Length x Width x Height: 5m x 5m x 5m);
2. New services bridge along eastern end of D&L Building (Length x Width: 45m x 1m). Mounted off the existing structure columns;
3. New feed area (hoppers feeding onto a new incline conveyor that will rise up to existing CV19). Hopper volume = 20 cubic meters each. Width x Length: 6m x 4m each. Total length 24m. This system will be mounted via chemical anchor to the existing concrete;
4. New incline conveyor that will rise up to existing conveyor CV19. (35m long, approx. 1.5m wide);
5. New dedicated baghouse for drafting the new feed area to be located along northern side of D&L Building. (Width: 3m, Length: 3m, total footprint: 5m x 5m x 5m). This will be mounted to the existing concrete foundation;
6. New main machine tip-end bunker & hygiene system hood. (Width x Length x Height: 6m x 9m x 4m). Storage bunkers created from portable concrete 'Beton' blocks for Pre-Treatment facility product. Reuse existing gas scrubber and install new duct work run only; and
7. New covered conveyor from the main machine tip-end to a bunker adjacent to the Blast Furnace feed preparation area.

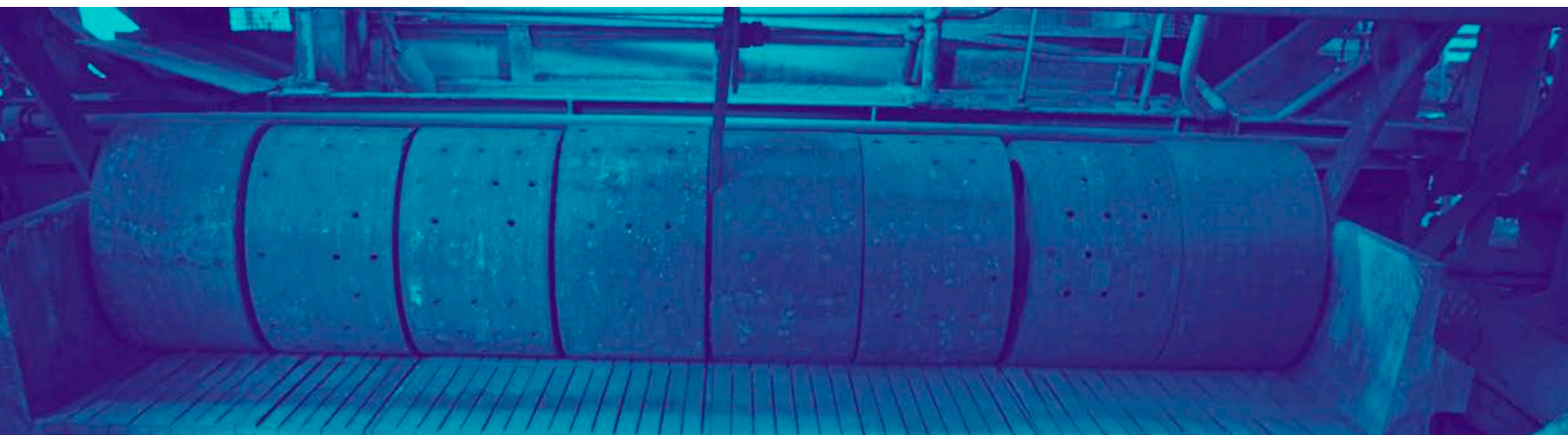

3. INFRASTRUCTURE MODIFICATIONS (Continued)

A new portable feeder for coke fines onto conveyor CV19 will be installed. The new coke fines feed system includes a bunker for storage and a short belt feeder (Telestack HF10T). The new temporary bunker will be made from concrete Beton blocks (**refer Figure 7**) will be located on the south east end of the D&L Building underneath the location of where conveyors CV56 and CV66 are located. The feeder is self-powered (by diesel generator) and controlled with a local control panel. A temporary portable free standing baghouse system will be used to mitigate any potential dust issues if they are identified.

A new Product storage bunker will be created using Beton concrete blocks (**refer Figure 7**) for the walls and concrete floor encasing rail iron for strength. The tip end bunker will have an emission hood over it to encapsulate any steam that is emitted from the hot product as it comes out of the Pre-Treatment machine. These emissions will be draughted to a wet scrubber (existing #6 Scrubber) to remove solids from the wet steam. The solids will be transferred to the existing 16m Thickener plant via an existing pipeline.

Figure 7 Concrete Beton Blocks to be utilised for Building bunkers



4. MANAGEMENT OF POTENTIAL ENVIRONMENTAL IMPACTS

Hazard potential is always present when handling and processing metal bearing materials. A risk driven approach is used to assess the potential for environmental or human health impacts arising from activities. Once the nature of the hazard is understood, and the risk quantified, control strategies are designed to reduce risk and mitigate harm.

Prior to developing the environmental control strategy to manage possible impacts, an assessment of feed material composition and quantity was made. This helps inform the development of the control strategy and is presented in Table 2. Table 3 details the proposed controls that will be implemented to mitigate impacts during operation of the Pre-Treatment Plant.

External feed materials for the Pre-treatment are delivered to site by ship and unloaded through the enviro-hopper which has emission reduction controls or into the existing Co-Treatment Shed (Note: A shed constructed to receive and store Lead concentrates and Zinc smelter leach products. It was named after the Co-Treatment project that included installation of the shed). The feed materials are transported by trucks around site, to either stockpiles or the Pre-Treatment Plant feed system. The blended feed for the Pre-Treatment Plant will include the materials listed in **Table 2**. The TSL Furnace, operating in parallel with the Treatment Plant will also draw feed materials from the stockpile quantities listed in **Table 2**.

The feed materials typically contain 24 to 35% water. This is because they are generated from wet processes. There is potential for material to dust when it dries out. This may occur when it is exposed to sunlight and wind on stockpiled surfaces or when spilled during handling. Dust binder is sprayed on the stockpiles to reduce dusting and the majority of the stockpiles have been covered with liners. Fog cannons are utilised when trucks are being loaded from stockpiles. Roadways and material handling areas are cleaned regularly by street sweepers.





CURRENT PRE-TREATMENT PLANT TRIAL LOCATION



Table 2. Feed materials for the Pre-Treatment Plant

Material and Source	Composition	Stockpile Quantity, tonnes	Consumption Rate, tonnes/month
Paragoethite from Nyrstar Hobart	4% Lead and 7% Sulphur	Approximately 704,000	Approximately 4,500
Lead Sulphate Leach Concentrate (LSLC) from Nyrstar Hobart	22% Lead and 14% Sulphur	Approximately 149,000	Approximately 6,600
Budel Leach Product from Nyrstar Budel, Netherlands	10% Lead and 12% Sulphur	Approximately 111,000	Approximately 7,000
Auby Leach Product from Nyrstar Auby, France	10% Lead and 12% Sulphur	None.	None. This is a potential feed material in the future.
Baghouse Sludge from Nyrstar Port Pirie	55% Lead and 8% Sulphur	Approximately 49,000	Approximately 750
Lead Sulphate from the Nyrstar Port Pirie Copper Plant (Andritz filter cake)	37% Lead and 22% Sulphur	Approximately 26,000	Approximately 1,000
Minor internal and external recycles			Approximately 500
Coke	Used as fuel to heat the feed materials		

Table 3 on page 34 lists the potential environmental impacts/hazards and the proposed controls for the Pre-Treatment Plant operation, including dust control measures. The Pre-Treatment Plant Dust Risk Management Trigger Action Response Plan (TARP) is included as Attachment C. The TARP defines the trigger points for cessation of plant operation.



The Rotunda at Memorial Park, Memorial Drive, Port Pirie

Table 3. Potential environmental impacts and control measures

Potential Environmental Impact	Control Measures	Monitoring	Reporting	Response Plan
EMISSIONS OF METAL-BEARING DUST TO AIR:				
Feed material storage, mixing and handling in the Pit. (Paragoethite, Lead Sulphate Leach Condensate, Budel Leach Product, Auby Leach Product, Baghouse Sludge, Lead Sulphate from Copper Plant)	<ul style="list-style-type: none"> • Use of fog cannons (as necessary) • Dust management Plan, including the High Wind protocol • Weather forecast (high-wind protocols) 	<ul style="list-style-type: none"> • Real-time particulate monitoring (EBAM) network • Camera Surveillance • Real-time Lead in Air Analyser. • Dust rover surveys of roadways. 	<ul style="list-style-type: none"> • Internal reporting by materials handling contractor (Hazell Bros). • Escalation to Plant Coach/Superintendent for enactment of Trigger Action Response Plan (TARP). 	<ul style="list-style-type: none"> • Follow high wind protocol and cease operations under high and/or extreme wind conditions, if required. • Enact Materials Handling Trigger Action Response Plan (TARP).
Truck to feed hopper	<ul style="list-style-type: none"> • Use of fog cannons during loading and unloading (as necessary) • Dust management Plan, including the High Wind protocol • Weather forecast (high-wind protocol) • Post approval this will be moved internal to D&L shed 	<ul style="list-style-type: none"> • Real-time particulate monitoring (EBAM) network • Camera Surveillance • Real-time Lead in Air Analyser. • Dust rover surveys of roadways. 	Escalation to Plant Coach/Superintendent for enactment of Trigger Action Response Plan (TARP).	<ul style="list-style-type: none"> • Follow high wind protocol and cease operations under high and/or extreme wind conditions, if required. • Enact Materials Handling Trigger Action Response Plan (TARP).
Feeding the Plant	<ul style="list-style-type: none"> • Sealed ground • Vacuum sweeping • Hopper Sprays • Fog Cannon • Materials Handling Trigger Action Response Plan (TARP) • Post approval this will be moved internal to D&L shed 	<ul style="list-style-type: none"> • Real-time particulate monitoring (EBAM) network • Camera Surveillance • Real-time Lead in Air Analyser. 	Escalation to Plant Coach/Superintendent for enactment of Trigger Action Response Plan (TARP).	<ul style="list-style-type: none"> • Follow high wind protocol and cease operations under high and/or extreme wind conditions, if required. • Enact Materials Handling Trigger Action Response Plan (TARP).
Operation of Plant	<ul style="list-style-type: none"> • Depth of materials bed on Strand. • Blower air volumes. • Draughting to the North & South baghouses. • Pre-Treatment Trigger Action Response Plan (TARP). 	<ul style="list-style-type: none"> • Real-time particulate monitoring (EBAM) network • Camera Surveillance • Real-time Lead in Air Analyser. 	Escalation to Plant Coach/Superintendent for enactment of Trigger Action Response Plan (TARP).	<ul style="list-style-type: none"> • Follow high wind protocol and cease operations under high and/or extreme wind conditions, if required. • Enact Pre-Treatment Trigger Action Response Plan (TARP).

Table 3 continued. Potential environmental impacts and control measures

Potential Environmental Impact	Control Measures	Monitoring	Reporting	Response Plan
EMISSIONS OF METAL-BEARING DUST TO AIR:				
Product bunker and delivery to the Blast Furnace	<ul style="list-style-type: none"> Product bunker draughted to wet scrubber Covered transfer conveyor Sealed ground Vacuum sweeping Hopper Sprays Fog Cannon Materials Handling Trigger Action Response Plan (TARP) 	<ul style="list-style-type: none"> Real-time particulate monitoring (EBAM) network Camera Surveillance Real-time Lead in Air Analyser 	Escalation to Plant Coach/Superintendent for enactment of Trigger Action Response Plan (TARP).	<ul style="list-style-type: none"> Follow high wind protocol and cease operations under high and/or extreme wind conditions, if required. Enact Materials Handling Trigger Action Response Plan (TARP).
NOISE:				
Noise from Pre-Treatment operation.	The Pre-Treatment facility is located approximately 700m from the nearest residence. Equipment selected to comply with occupational health and safety noise limits.	Monitoring by operations to identify if equipment is malfunctioning	Maintenance request raised if required.	Malfunctioning equipment to be repaired or replaced.
ODOUR:				
Sulphur Dioxide emissions from Pre-Treatment operation	The Pre-Treatment process is draughted to the North and South Baghouses. The gases are discharged from the Tall Stack.	There is a Sulphur Dioxide monitor in the Tall Stack.	Tall Stack Sulphur concentrations are utilised by Fume Control.	Tall Stack Sulphur emissions are controlled by the Tall Stack Sulphur Protocol. This limits the 24-hour average Sulphur concentration.
WASTEWATER VOLUMES & HEAVY METAL CONCENTRATIONS:				
Wet scrubber effluent, product bunker water sprays and washdown water from the Pre-Treatment Plant (approximately 28 m3 per hour from Blast Furnace, Cadmium Plant, Pre-Treatment Plant, Wharf sump and Briquetting Plant)	Water is directed to the Process Effluent Treatment System (PETS) via the 16m thickener. The PETS Plant adjusts wastewater pH and removes heavy metals. The PETS Plant has sufficient capacity to treat this wastewater flowrate.	Real-time monitoring of the Process Effluent Treatment System (PETS) performance.	An operator is based at the PETS Plant and monitors plant performance.	PETS operation is adjusted to maintain effluent quality. The plant is able to be put on recycle if effluent is outside the target range.
WASTE GENERATION:				
Potential generation of off-specification Pre-Treatment Product.	Selection of the feed mix. Plant operating parameters. Storage of off-specification in the Pit. Reprocessing of off-specification material from the Pit.	Regular assays of feed mixes. Inspection of product quality (physical). Regular assays of product.	Shift reports. Laboratory data.	Adjustments to feed mix or operating parameters. Cease operation until quality issue resolved.



5. ENVIRONMENTAL PERFORMANCE FOR CURRENT TRIAL TO DATE

Detailed environmental monitoring and analysis has been undertaken throughout the operation of the Pre-Treatment Plant trial during 2021. Air quality data has been collected in the near vicinity of the Pre-Treatment Plant as well as further afield under different operating and climatic conditions.

Data analysis has been conducted using the Ellen Street dust monitor (EBAM PM¹⁰) and the Dental Clinic Metals-in-Air Analyser data to identify the impact of the Pre-Treatment facility operations on air quality performance during northerly wind conditions for the period 01/01/21 to 31/10/21. Summary statistics are presented in **Table 4**. The data has been presented for periods when the Pre-Treatment Facility was 'Off' and when it was 'On'.

The median, mean and 3rd quartile values were all lower during the Pre-Treatment 'On' periods compared to the Pre-Treatment 'Off' periods for the Metals In Air Analyser (MIAA) Lead (Pb), Ellen Street (EST) dust (PM₁₀) hourly average (Hr Avg) and Ellen Street (EST) real-time dust (PM₁₀ RT). This indicates that the Pre-Treatment operations generally had no discernible additional impact compared to overall emissions from the site during the period reviewed.

The maximum concentration for the Metals In Air Analyser (MIAA) Lead (Pb) is higher during Pre-Treatment 'On'. However, as noted above, the median and mean averages are lower when the plant is 'On'. This indicates the current Trigger Action Response Plan (TARP) is effective at managing dust and reducing the Lead in air impact. In addition to resourcing ramp up delays, the implementation of the TARP resulted in significantly less plant operating time (2,302 data points for 'Off' compared to 104 data points for 'On' under northerly wind conditions) as the plant was shut down when emissions were observed.

Although the data does not indicate a discernible increase in impact. Improvement projects are listed in Table 5 and include improvements to the hygiene ventilation system at the eastern end of the Pre-Treatment main machine. The lower than expected operating time has meant that air quality impacts have not been tested under all weather conditions to date.



5. ENVIRONMENTAL PERFORMANCE FOR CURRENT TRIAL TO DATE

Table 4. Summary Statistics for northerly wind during Pre-Treatment 'Off' and 'On'

Pre-Treatment Wind Filtered (10° – 30°)		
Pre-Treatment 'Off' - 2302 data points		
MIAA Pb ng/m3	EST PM10 Hr Avg µg/m3	EST PM10 RT µg/m3
Min. : 0	Min. : 0.00	Min. : 0.00
1st Qu.: 229	1st Qu.: 16.00	1st Qu.: 16.00
Median : 1,280	Median : 29.00	Median : 29.00
Mean : 3,307	Mean : 34.28	Mean : 34.37
3rd Qu.: 4,992	3rd Qu.: 42.50	3rd Qu.: 43.00
Max. : 28,800	Max. : 222.00	Max. : 208.00
NA's : 312	NA's : 43	NA's : 20
Pre-Treatment 'On' - 104 data points		
MIAA Pb ng/m3	EST PM10 Hr Avg µg/m3	EST PM10 RT µg/m3
Min. : 0	Min. : 1.00	Min. : 0.00
1st Qu.: 194	1st Qu.: 14.00	1st Qu.: 15.75
Median : 540	Median : 23.50	Median : 23.00
Mean : 2,824	Mean : 27.83	Mean : 30.03
3rd Qu.: 1,256	3rd Qu.: 38.00	3rd Qu.: 40.25
Max. : 32,256	Max. : 71.00	Max. : 78.00
NA's : 1		



5. ENVIRONMENTAL PERFORMANCE FOR CURRENT TRIAL TO DATE

Figure 8 and Figure 9 show polar plots that depict the lead in air concentrations (represented by colour scale) at different wind speeds (i.e. the rings) against the wind directions. The plots show the impact of emissions at a monitoring location from different emission sources under differing wind speeds and directions. The location of the Pre-Treatment plant is in the North Eastern quadrant of each of the plots.

The Figure 8 polar plots reveal an increased Lead loading at the Metals in Air Analyser during Pre-Treatment 'Off' compared to 'On'. A signal is present from the Pre-Treatment in the 'On' polar plot which indicates there is a contribution from Pre-Treatment. The contribution is small compared to other Lead sources during Pre-Treatment 'Off', however the dataset for 'Off' time is far greater than 'On' time. The improvement projects identified below aim to reduce this contribution.

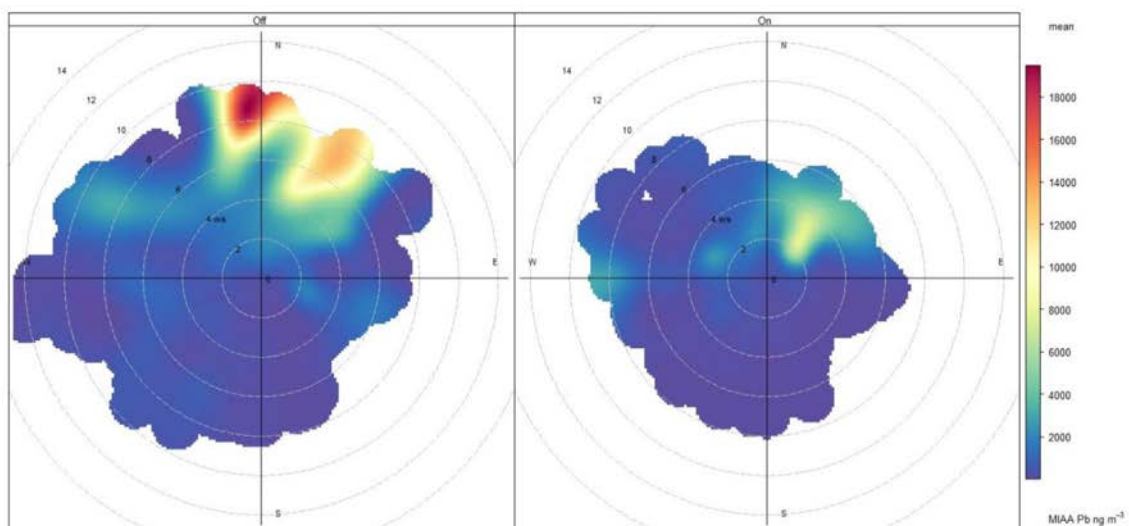

Figure 8. Polar Plots of Metals in Air Analyser (MIAA) Lead (Pb) ng/m³ mean values during Pre-Treatment 'Off' and 'On'



5. ENVIRONMENTAL PERFORMANCE FOR CURRENT TRIAL TO DATE

The Figure 9 polar plots of Ellen Street (EST) dust (PM10 real-time) ug/m³ indicate a similar impact to the Metals in Air Analyser Lead polar plots. They show a small contribution signal from the Pre-Treatment during 'On', however it is smaller than during 'Off.'

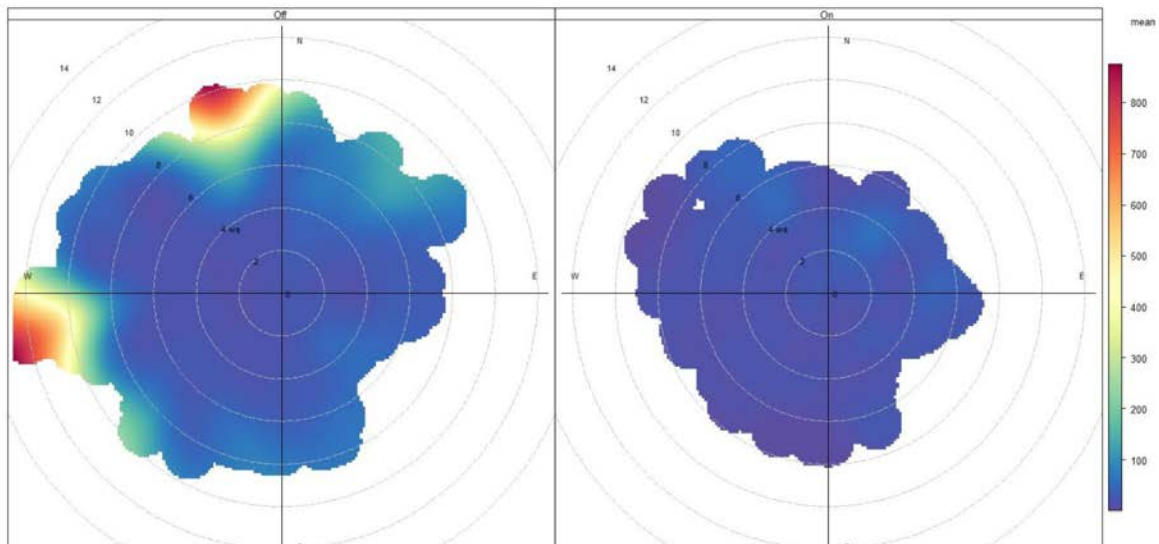

Figure 9. Polar Plot of Ellen Street (EST) dust (PM10 real-time) ug/m³ mean values during Pre-Treatment 'Off' and 'On'



5. ENVIRONMENTAL PERFORMANCE FOR CURRENT TRIAL TO DATE

A number of projects/improvements have been identified during the Pre-treatment Plant Trial and will improve the effectiveness of the environmental control measures, refer **Table 5**.

Table 5 Current status and expected completion dates for improvement projects

Improvement Project	Expected Completion Date
<p>Moisture and Windbox Control</p> <ul style="list-style-type: none"> · GPA have been engaged to improve the quality of moisture control and windbox control. Improvements in these controls will increase product quality and reduce the potential of fines generation that may cause fugitive dusting. · Windbox maintenance works and calibrations continue to occur to improve product stability 	<p>Current control systems working as per design. Task of reviewing and improving will be ongoing.</p> <p>Additional moisture control improvements in 3 to 6 months.</p>
<p>Product Stability</p> <ul style="list-style-type: none"> · Heating of the product is now creating a hard crust layer on the bottom of the product however is dusting on the top layer. Improvements from projects and in particular moisture and windbox control will aid in creating a product that will fully crust reducing the fines generation that may cause potential fugitive dusting. 	<p>Completed, ongoing monitoring implemented to ensure product quality is maintained.</p>
<p>Product Bunker Upgrade and Optimisation of Hygiene System</p> <ul style="list-style-type: none"> · Modifying the wet draughting system to improve dust extraction capacity by upgrading the duct size and layout. This will reduce moisture in the dry draughting system therefore reducing blockages · Increase dry draughting capacity to improve dust extraction from bunker hood · Increase bunker hood capacity to reduce fugitive dust from escaping product bunker and hood. 	<p>Dry draughting capacity – completed.</p> <p>The new ducting work for Product bunker and F14 fan has been completed.</p> <p>Redesign of product transfer to a new large product bunker. Expected completion in 12 to 18 months.</p>
<p>Material Movements</p> <ul style="list-style-type: none"> · Exhaust air from larger front-end loaders have been identified as a contributor to dust generation within the tip end bunker. A smaller loader is being trialled to determine if the impact from exhaust air is reduced without compromising on more-frequent material movements. 	<p>Smaller loader being utilised.</p> <p>Change in how loaders remove material from Tip End Bunker, activity is staged so that draughting is utilised evenly.</p>

5. ENVIRONMENTAL PERFORMANCE FOR CURRENT TRIAL TO DATE

Table 5 (continued) Current status and expected completion dates for improvement projects

Improvement Project	Expected Completion Date
<p>Dwight & Lloyd (D&L) building cladding</p> <ul style="list-style-type: none"> • Northern wall will be cladded and will be continued to eastern side and roof. This will reduce atmospheric influence of operation and in turn reduce potential fugitive dust generation. 	<p>Partially complete (50%). Expected completion July 2022.</p>
<p>New Feed System</p> <ul style="list-style-type: none"> • A new feed system is currently being designed to meet the plant requirements. • It will be relocated to the D&L Building. 	<p>The new feed system is expected to be installed in 12 to 18 months.</p>
<p>Misting system has been installed external to tip end bunker.</p> <ul style="list-style-type: none"> • Continue to improve and add mist sprays as required • Fine turning the amount and mist size 	<p>Changes made to the nozzles of the product bunker internal sprays. Fog cannon positioned permanently on the southern side of product bunker.</p>

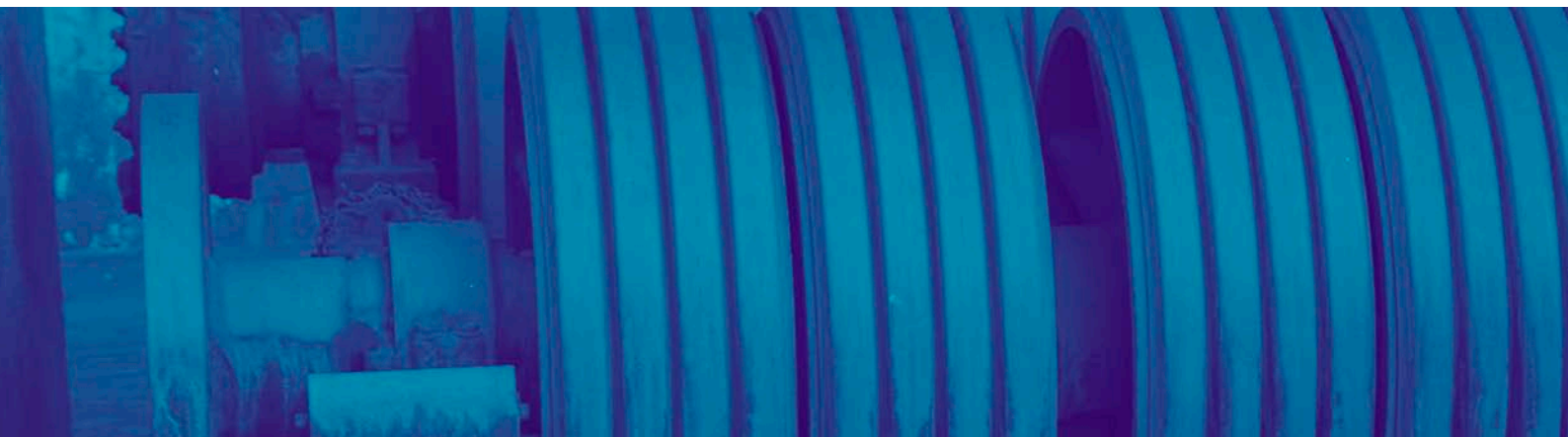

6. AIR DISPERSION MODELLING OF EMISSION SCENARIOS

To estimate the influence on metal emissions to air associated with operating the Pre-Treatment plant, Nyrstar developed a number of operating scenarios to support the development of an air dispersion model. Air quality modelling specialists were then engaged to undertake the modelling exercise in accordance with the South Australian Environment Protection Authority's Ambient Air Quality Assessment (2016) guide.

Table 6, presents the different scenarios assessed using the model. In addition to the Pre-Treatment plant, the model includes a large range of emission sources from other operating plant as well as fugitive sources such as dust from surfaces. These emission sources, combined with meteorological conditions, support the estimation of Ground Level Concentrations (GLCs) outside the boundaries of the site.

The current facility operation is represented by Scenario 2. The site emissions during the Pre-Treatment Trial are represented by Scenario 3. It is expected that the Pre-Treatment Plant would operate for 3 to 6 years, until the stockpiles are exhausted (Scenarios 1A_1 and 1A_2). This would be followed by a return to the current emissions profile, without the stockpiles (Scenario 1B). Scenario 1B includes the new Product Recycling Facility.

The emissions scenarios were based on historical and recent plant emissions data and the National Pollution Inventory estimation techniques, as requested by the Environment Protection Authority. The National Pollutant Inventory emissions data includes normal and abnormal operating conditions. The modelled GLCs were compared against criteria stipulated in Nyrstar's EPA licence and/or the pollutant GLC specified in the Schedule 2 of the Environment Protection (Air Quality) Policy 2016.

The site emissions during operation of the Pre-Treatment Plant are anticipated to reduce over time as additional improvement projects are completed, including:

- Nyrstar completed \$25M worth of Lead in air reduction projects in 2021. There is \$25M in planned capital investment in 2022 to contribute to improved environmental performance. Nyrstar will construct a Product Recycling Facility that will replace the materials handling conducted within the Pit area, which is expected to have a further significant beneficial impact on air quality.
- Nyrstar has adopted additional controls to mitigate fugitive dust emissions. The fugitive emissions from materials handling and plant operation will continue to reduce as further environmental controls are implemented, refer **Table 5**. The fugitive emissions account for 40% of the estimated Pre-Treatment Plant Lead emissions

6. AIR DISPERSION MODELLING OF EMISSION SCENARIOS

- Blast Furnace emissions are expected to be lower during the operation of the Pre-Treatment Plant, due to more consistent feed availability delivering increased furnace stability. Blast Furnace fugitive emissions account for approximately 15% of the estimated whole-of-smelter Lead emissions; and
- The atmospheric dispersion modelling of the Pre-Treatment Plant emission scenarios was conservative because it assumed that the materials handling operations would continue in all weather conditions. However this is unlikely due to the implementation of the High-Wind Protocol and Pre-Treatment Plant Trigger Action Response Plan during plant operation.

**Table 6. Pre-Treatment Plant Emission Scenarios
(with estimated annualised total site emissions)**

Scenario Number	Title	Parameters Adjusted	Total PM₁₀ Dust emissions (kg/year)	Total lead emissions (kg/year)	Total Arsenic emissions (kg/year)	Total Cadmium emissions (kg/year)	Total Zinc emissions (kg/year)
1A_1	Pre-Treatment operating, with stockpiles at start	Pre-Treatment operating. Additional feed handling controls in place.	250,674	62,597	2,488	2,667	41,160
1A_2	Pre-Treatment operating, with stockpiles after 18 months.	Pre-Treatment operating. Additional feed handling controls in place.	242,943	60,953	2,478	2,622	40,623
1B	Pre-Treatment finished, no stockpiles remaining (Product Recycling Facility)	Pre-Treatment finished and stockpiles removed.	192,322	46,654	2,193	2,559	32,798
2	Current operation (no Pre-Treatment, with stockpiles)	No Pre-Treatment. Stockpiles remain.	251,275	65,105	2,560	2,683	44,797
3	Pre-Treatment Trial	Pre-Treatment operating. Fugitive emissions based on sampling in Sept 2021.	254,628	65,341	2,565	2,713	44,887

Table 7. Comparison of Pre-Treatment Plant Lead Emission Scenarios with the Public Environment Report (PER)

ID	Source	PAE Holmes 2010-11	PER Current (Revised 2010-11)	PER Predicted Transformation	1A_1_ Pre-Treatment With Stockpiles at Start	1A_2_ Pre-Treatment With Stockpiles at 18 Months	1B_No Pre-Treatment & No Stockpiles (Product Recycling Facility)	2_Current Operations (2021)	3_ Pre-Treatment Trial
		kg/year	kg/year	kg/year	kg/year	kg/year	kg/year	kg/year	kg/year
SHIP	Ship Unloading	2,052	2,051	2,051	1,557	1,557	1,557	1,557	1,557
PP	Proportioning Plant (Mixing Plant)	1,637	1,701	850	164	164	164	164	164
BLAST FURNACE SOURCES									
BF	Blast Furnace	12,032	14,518	4,363	21,587	21,587	22,950	23,045	23,045
TDO	Telpher Drop Off	1,622	421	-	-	-	-	-	-
Sub-total Blast Furnace sources		13,654	14,938	4,363	21,587	21,587	22,950	23,045	23,045
PRIMARY PROCESS SOURCES									
SM	Main Machine	6,438	7,341	-	469	293	-	-	136
SB	Sinter Bins	2,895	751	-	-	-	-	-	-
BBDP	Battery Bay & Duck Pond	224	236	-	-	-	-	-	-
EN	Eagles Nest	13,357	3,464	-	-	-	-	-	-
DL	D&L building	5,044	5,240	-	-	-	-	-	-
NOF	TSL (EBS) Furnace	-	-	1,483	1,939	1,939	1,939	2,664	2,664
Sub-total primary process sources		27,959	17,033	1,483	2,408	2,232	1,939	2,664	2,801
OPAVS	All other process area Volume sources	1,561	1,561	1,561	3,021	3,021	3,021	3,021	3,021
APAPS	All process area Point sources	3,588	3,588	3,588	2,227	2,077	1,828	1,828	1,927
SLAG FUMING PROCESS SOURCES									
SF	Slag Fumer	9,147	9,145	9,145	14,579	14,579	10,648	14,579	14,579
KDR	Kilns Dust Recovery System	3,014	3,013	3,013	2,196	2,196	2,196	2,196	2,196
Sub-total Slag Fuming process sources		12,161	12,161	12,158	16,776	16,776	12,844	16,776	16,776
P1-21	Paved roads	1,553	1,553	311	1,605	1,605	748	1,483	1,483
PIT SOURCES									
OPAS	Other Pit area sources	1,430	1,430	1,430	9,523	8,204	106	10,969	10,969
U1-19	Unpaved roads	2,186	2,186	437	3,211	3,211	1,497	2,966	2,966
SRS	Primary Returns, Sludge & Residue Mixes stockpiles	4,013	4,013	803	517	517	-	632	632
Sub-total Pit area sources		7,630	7,630	2,670	13,251	11,932	1,603	14,566	14,566
TOTAL		71,794	62,213	29,036	62,597	60,953	46,654	65,104	65,341

6. AIR DISPERSION MODELLING OF EMISSION SCENARIOS

Table 7. provides a comparison of the total Lead emission scenarios modelled for the amendment of the Public Environment Report. The PER predicted a significant reduction in total Lead in air emissions. It is noted that the predicted reduction in total Lead in air emissions in the amendment is less than the reduction predicted in the PER. The difference in predicted total Lead emissions is the result of some emissions estimates being increased (mainly the Blast Furnace and materials handling in the Pit). If the adjustments to the Blast Furnace and material handling emission estimates are removed, the predicted total Lead emissions are the same as that predicted by the PER (29,135 kg in the amendment compared with 29,036 in the PER). The basis for increasing the two emission estimates was:

- The Blast Furnace operation has not reached the stability anticipated by the PER. This is because the TSL Furnace is still ramping up to the full production rate and has not yet provided consistent slag block quality; and
- Additional field studies in the materials handling areas has identified emission rates greater than the rates from the National Pollutant Inventory manuals.

Stockpiles at Nyrstar Port Pirie site are to be removed as part of this Pre-Treatment plant project



6. AIR DISPERSION MODELLING OF EMISSION SCENARIOS

The graphs in **Figure 10** show the range of Lead concentrations modelled across the four monitoring locations for each of the five different scenarios. A comparison of the results for each scenario (1a_1, 1a_2, 1b and 3) against the base-case (scenario 2) shows a general trend of decreasing predicted Lead concentrations.

Lead

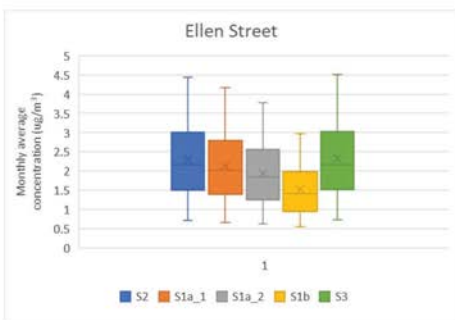

Figure 13 Ellen Street – Lead monthly average concentration box plot

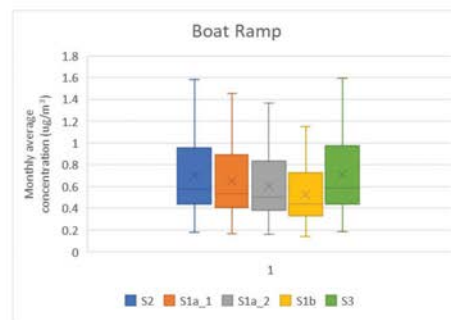

Figure 14 Boat Ramp – Lead monthly average concentration box plot

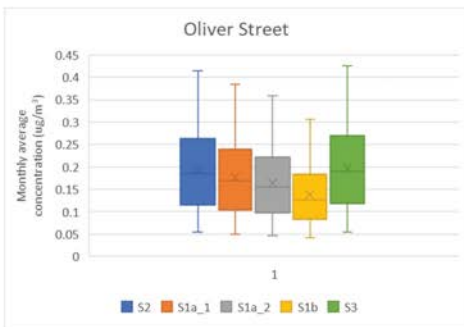

Figure 15 Oliver Street – Lead monthly average concentration box plot

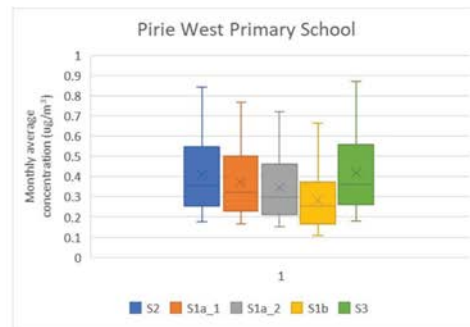

Figure 16 Pirie West Primary School – Lead monthly average concentration box plot

Figure 10. Predicted Lead monthly average concentration.





6. AIR DISPERSION MODELLING OF EMISSION SCENARIOS

The predicted absolute and percentage differences in Lead concentrations are shown in **Figure 11**.



Figure 11. Predicted absolute and percentage difference - lead.



As part of the Nyrstar site's emission reduction strategy, stockpiles have been tarped to reduce emissions being generated by wind.



7. VARIATIONS FROM THE 2013 PUBLIC ENVIRONMENT REPORT

The Sinter Plant was decommissioned in November 2019, when the Top-Submerged Lance (TSL) Furnace became available to provide feed material for the Blast Furnace. This is consistent with Section 6.3.3 of the Transformation Public Environment Report (PER). In Section 6.3.2, the existing sinter plant was identified as a facility that would become redundant and be demolished at a later stage.

The PER emphasises the lead-in-air benefits associated with the replacement of the sinter plant with modern enclosed bath smelting technology. The sinter plant was considered the largest contributor to lead in-air and the new technology was assumed as being a zero lead-in-air contributor. The challenge of Blast Furnace instability as a consequence of inadequate feed volumes during the ramp-up of the Top-Submerged Lance (TSL) Furnace was not anticipated in the PER. The repurposing of redundant plant to address this deficiency will contribute to reduced emissions of lead-in-air and is therefore consistent with the PER stated objectives of the Transformation.

The use of the redundant strand for the Pre-Treatment Plant to condition paragoethite (PG) is not comparable to sintering and the challenges with emissions of Sulphur Dioxide (SO₂) and lead are not equivalent. The use of equipment from the old sinter plant for the purposes of reducing emissions of lead in air is consistent with the overarching focus of the PER on lead-in-air reduction.

It is proposed to relocate the Co-Treatment Shed Expansion included in the 2013 Public Environment Report (south of the Co-Treatment Shed) to north of the Co-treatment Shed. The building has been renamed the Product Recycling Facility.



nyrstar

PORT PIRIE

nyrstar

8. CONCLUSION

The project benefits include improved environmental and economic outcomes. It will further enable Nyrstar's continuing efforts to reduce emissions, bringing forward a sustainable improvement to air quality once materials are no longer stored outside. It is noted that this project is also part of an overarching lead in air reduction strategy that includes various projects and initiatives that will continue to improve air quality in Port Pirie over time, including the Product Recycling Facility, covering stockpiles and erecting domes over material handling activities. These efforts also align with the South Australian Government's strategic priority to improve health outcomes for children, particularly in the first five years of life. The new process will aid in securing both a short- and long-term sustainable future for operations in Port Pirie, provide up to 40 additional local jobs and will aid Nyrstar's continued contribution to the economic development of Port Pirie and South Australia.

Nyrstar has demonstrated ongoing commitment to reducing lead emissions to air and improving the health of the community, thus delivering a sustainable future for the facility, Port Pirie and the wider region. The key environmental impact from the project will be on air quality. Overall, the project is anticipated to deliver a significant long-term sustainable reduction in emissions (up to 28% for lead) from the project baseline of actual performance at 31 December 2020 (i.e. the relevant comparison year at the time the project was originally conceived). While there are anticipated to be some ongoing emissions during the plant operation, modelling has demonstrated the ongoing all-of-site emission reduction work mitigates these emissions.

Volume II - Amendment to the Public Environmental Report for the Nyrstar Port Pirie Smelter Transformation Proposal - Pre-Treatment Plant

Attachment A – Location of the proposed Pre-Treatment Plant

Attachment B – Layout of the proposed Pre-Treatment Plant

Attachment C - Dust Management Plan and Trigger Action Response Plans (TARPs)

Attachment D – Pre-Treatment Plant Air Quality Assessment Report



9. GLOSSARY OF TECHNICAL TERMS

Baghouse: An air pollution control device and dust collector that removes particulates released from commercial processes out of the air.

Bunker: A structure with walls on three sides, used for storing bulk solid materials.

Blast Furnace: In a blast furnace, fuel (coke), ores, and flux (limestone) are continuously supplied through the top of the furnace, while a hot blast of air (with oxygen enrichment) is blown into the lower section of the furnace through a series of pipes called tuyeres, so that the chemical reactions take place throughout the furnace as the material falls downward. The end products are molten metal and slag phases tapped from the bottom, and waste gases (flue gas) exiting from the top of the furnace. The downward flow of the feed along with the flux in contact with an up-flow of hot, carbon monoxide-rich combustion gases is a counter current exchange and chemical reaction process.

Conveyor: A piece of mechanical handling equipment that moves materials from one location to another.

Co-Treatment Shed: A large shed constructed to receive and store Lead concentrates and Zinc smelter leach products. It is named after the Co-Treatment project which included the installation of the shed.

Enviro-hopper: Hopper with draughting and air cleaning, used during unloading of material from a ship.

Fugitive emissions: Unintended releases of gases and dust from an industrial process.

Hopper/bins: A funnel-shaped container in which materials, such as grain or coal, are stored in readiness for dispensation.

PM₁₀ dust: Dust with particles smaller than 10 microns in diameter.

Pre-Treatment Plant Main Machine/Strand: Metal conveyor bed that moves a layer of feed material and fuel (coke) through an ignition burner and draughting (wind boxes). Due to the elevated temperature the chemically-bound water leaves the material and it fuses together into lumps.

Pre-Treatment Plant Tip-End: The eastern end of the strand, where material that has been heated and fused drops into a bunker.

Product Recycling Facility: Extension of the Co-Treatment Shed to the north.

Scrubber: Air pollution control device that removes particulates from an exhaust gas stream.

Windbox: A plenum chamber that supplies air for combustion to a stoker or gas burner.

Zinc Smelter Leach Products: Includes Paragoethite, Lead Sulphate Leach Concentration, Budel Leach Product and Auby Leach Product. Zinc Smelters utilise a leach circuit to remove impurities from roasted Zinc concentrates before electrolysis is used to electroplate Zinc metal. The impurities removed contain iron, lead, gold, silver and copper. Some residual zinc is retained in the leach product.



Volume II - Amendment to the Public Environmental Report for the Nyrstar Port Pirie Smelter Transformation Proposal - Pre-Treatment Plant

Page number

- 55:** Attachment A - Location of the proposed Pre-Treatment Plant
- 66:** Attachment B - Layout of the proposed Pre-Treatment Plant
- 70:** Attachment C - Dust Management Plan and Trigger Action Response Plans (TARPs)
- 84:** Attachment D - Pre-Treatment Plant Air Quality Assessment Report

Certificate of Title

Title Reference	CT 6167/721
Status	CURRENT
Easement	YES
Owner Number	70785341
Address for Notices	ELLEN STREET PORT PIRIE SA 5540
Area	NOT AVAILABLE

Estate Type

FEE SIMPLE

Registered Proprietor

NYRSTAR PORT PIRIE PTY. LTD. (ACN: 008 046 428)
OF RISDON ROAD LUTANA TAS 7009

Description of Land

ALLOTMENT 50 DEPOSITED PLAN 12528
IN THE AREA NAMED PORT PIRIE
HUNDRED OF PIRIE

Last Sale Details

There are no sales details recorded for this property

Constraints

Encumbrances

Dealing Type	Dealing Number	Beneficiary
LEASE	12963802	AIR LIQUIDE AUSTRALIA SOLUTIONS PTY. LTD. (ACN: 602 866 106)
LEASE	12963803	AIR LIQUIDE AUSTRALIA SOLUTIONS PTY. LTD. (ACN: 602 866 106)

Stoppers

NIL

Valuation Numbers

Valuation Number	Status	Property Location Address
3525006054	CURRENT	Lot 50 ELLEN STREET, PORT PIRIE, SA 5540

Notations

Dealings Affecting Title

NIL

Notations on Plan

NIL

Registrar-General's Notes

PLAN FOR LEASE PURPOSES VIDE G299/2000
APPROVED FILED PLAN FOR LEASE PURPOSES FX250303
APPROVED FILED PLAN FOR LEASE PURPOSES FX251483
APPROVED FILED PLAN FOR LEASE PURPOSES FX252669

Administrative Interests

NIL



A

B

C

D

E

F



SITE LOCATION LAYOUT
PRODUCT RECYCLING FACILITY



PLAN VIEW
NEW PRODUCT RECYCLING FACILITY
SCALE: 1:600



PERSPECTIVE VIEW
NORTH EAST ASPECT
PRODUCT RECYCLING FACILITY



PERSPECTIVE VIEW
NORTH WEST ASPECT
PRODUCT RECYCLING FACILITY

NOTE:

1. THE FLOOR AREA OF THE NEW FACILITY SHALL BE 6850 SQM & HEIGHT SHALL BE 13M APPROXIMATE. DIMENSIONS ARE ONLY APPROXIMATE. FINAL DETAILS SHALL BE CONFIRMED AFTER DETAILED DESIGN.
2. ENCLOSED VOLUME TO PREVENT FUGITIVE DUST
3. CONCEYOR FEEDING SYSTEM: LENGTH 60M APPROX.
4. THIS DRAWING SHOWS A CONCEPT ARRANGEMENT ONLY. DETAILED DESIGN CONFIRMATION AND A FORMAL RISK ASSESMENT SHALL BE CONDUCTED PRIOR TO FINALISATION OF THIS ARRANGEMENT.

TOTAL PART/ASSY MASS: 4628906.6 kg

PRELIMINARY INFORMATION ONLY

ALL DIMENSIONS IN mm U.O.N. FINISHES: MACHINING X ± 0.5 J 0.2/100 X.X ± 0.25 / 0.2/100 X.XX ± 0.1 @ 0.05 X"X"X" ± 0.5 ✓/1.6 EXCEPT SHOWN SEPARATELY UP TO 1000mm ± 2 OVER TO 1000mm ± 3 NON-CUMULATIVE X"X"X" ± 2/100 INVENTOR MODEL 90° ANGLE PROJECTION UNLESS OTHERWISE NOTED (DRAWN TO AS1100)		 NYRSTAR PORT PIRIE A.B.N. 31 008 046 428 PO BOX 219 PORT PIRIE SA 5640 https://www.nyrstar.com/		DRAWN: KTM 15/10/2021 CHKD: MK 15/10/2021 DEGN: APPD: PROJECT No.:	PLANT PRODUCT RECYCLING FACILITY CONCEPT BUILDING PROPOSED SETTING CONCEPTUAL LAYOUT	SCALE 1 : 300	DRG No. SK-682-0001-01	REV. A
A 15/10/2021 ISSUED FOR CONCEPTUAL REVIEW KTM MK KTM	DRN CHKD DEGN APPD CLIENT	REVISION HISTORY						

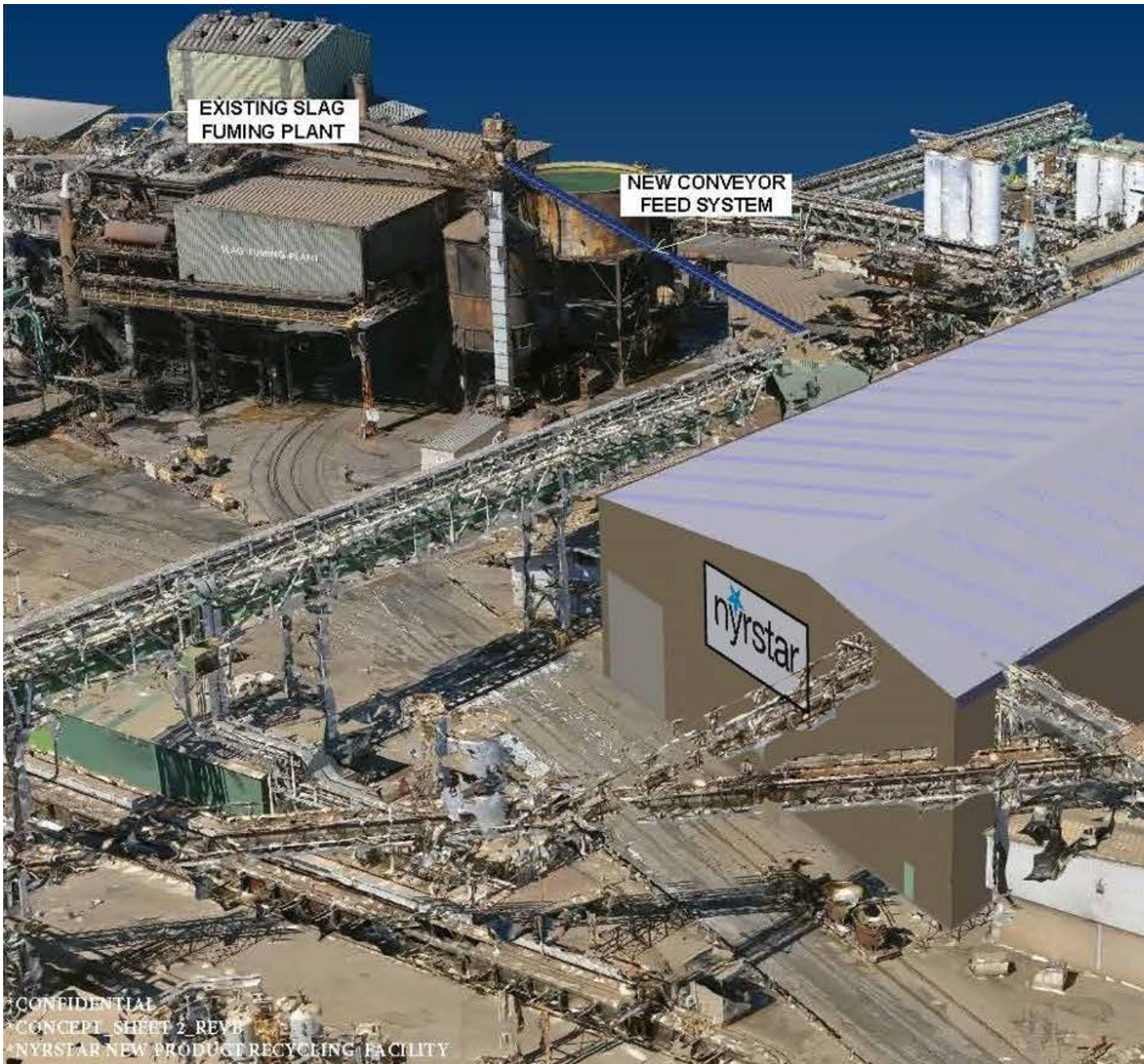

PERSPECTIVE VIEW

NORTH EAST ASPECT _NEW PRODUCT RECYCLING FACILITY

NOTES:

1. THE FLOOR AREA OF THE NEW FACILITY SHALL BE 6850 SQM & HEIGHT SHALL BE 13M APPROXIMATE. DIMENSIONS ARE ONLY APPROXIMATE. FINAL DETAILS SHALL BE CONFIRMED AFTER DETAILED DESIGN.
2. ENCLOSED VOLUME TO PREVENT FUGITIVE DUST
3. CONVEYOR FEEDING SYSTEM: LENGTH 60M APPROX.
4. THIS DRAWING SHOWS A CONCEPT ARRANGEMENT ONLY. DETAILED DESIGN CONFIRMATION AND A FORMAL RISK ASSESSMENT SHALL BE CONDUCTED PRIOR TO FINALISATION OF THIS ARRANGEMENT.



ING FACILITY

PRELIMINARY INFORMATION ONLY

REV	DATE	REVISION DESCRIPTION	DRN	CHKD	DEGN	APPD	CLIENT
A	15/10/2021	ISSUED FOR CONCEPTUAL REVIEW	KTM	MK	KTM		
REVISION HISTORY							

ALL DIMENSIONS in mm U.O.N.
 TOLERANCES:
 MACHINING X ± 0.5 ± 0.2/100
 X.X ± 0.25 ± 0.2/100
 X.XX ± 0.1 ± 0.05
 X*X*X ± 0.5 ± 0.16
 UP TO 1000mm ± 2
 OVER TO 1000mm ± 3
 NON-CUMULATIVE
 X*X*X ± 2/100

INVENTOR MODEL
 BUILD: 264
 RELEASE: 2018.3
 MODEL VERSION: v28
 STATUS: Working Progress
 MASS: 442896.6 kg
 VOLUME: 15879752674.42 m³

nyrstar
 NYRSTAR PORT PIREE A.B.N. 51 038 046 428
 PO BOX 219 PORT PIREE SA 6540
<https://www.nyrstar.com/>
 © COPYRIGHT RESERVED
 THIS DRAWING IS THE PROPERTY OF NYRSTAR (SIB) P/B
 AND IS SUBJECT TO RETURN ON DEMAND. IT IS SUPPLIED
 FOR USE ONLY IN CONNECTION WITH THE PROJECTS OR
 CONTRACTS OF THIS ORGANISATION UPON THE EXPRESS
 CONSENT THAT IT IS NOT TO BE USED OBJECTIVELY OR
 INDIRECTLY IN ANY WAY DETRIMENTAL TO THE INTERESTS
 OF NYRSTAR AND ITS SUBSIDIARIES.

DRAWN: KTM 15/10/2021
 CHKD: MK 15/10/2021
 DEGN:
 APPD:
 PROJECT No.:

PLANT
 PRODUCT RECYCLING FACILITY
 CONCEPT
 BUILDING PROPOSED SETTING
 CONCEPTUAL NORTH EAST VIEW
 SCALE: 1:300
 DRG No. SK-682-0001-03
 REV. A

TOTAL PARTY/ASSY MASS: 4626906.6 kg

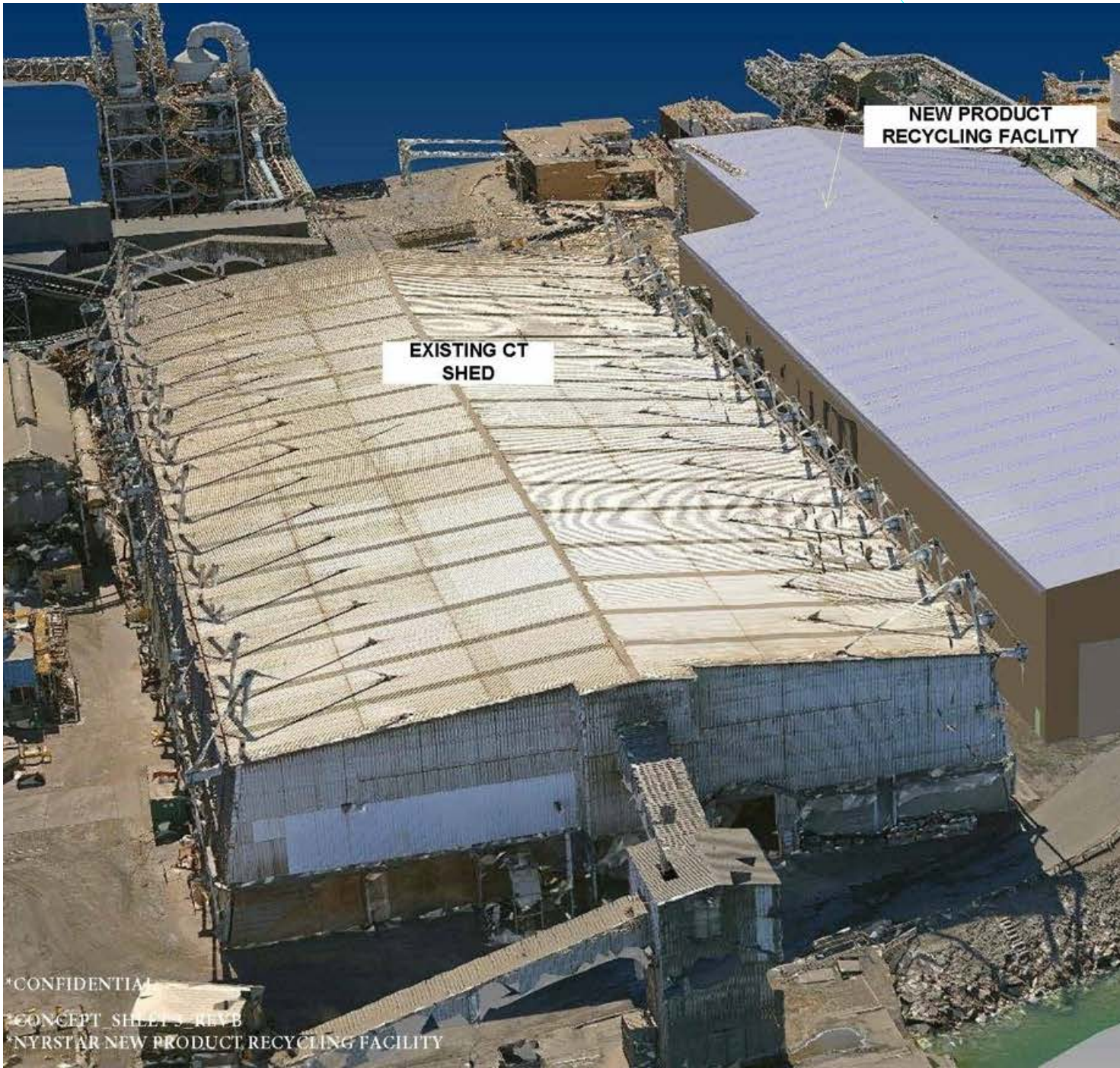

*CONFIDENTIAL
 *CONCEPT SHEETS REV B
 *NYRSTAR NEW PRODUCT RECYCLING FACILITY

PER
 NORTH WEST ASP

NOTES:

1. THE FLOOR AREA OF THE NEW FACILITY SHALL BE 6850 SQM & HEIGHT SHALL BE 13M APPROXIMATE. DIMENSIONS ARE ONLY APPROXIMATE. FINAL DETAILS SHALL BE CONFIRMED AFTER DETAILED DESIGN.
2. ENCLOSED VOLUME TO PREVENT FUGITIVE DUST
3. CONCEYOR FEEDING SYSTEM: LENGTH 60M APPROX.
4. THIS DRAWING SHOWS A CONCEPT ARRANGEMENT ONLY. DETAILED DESIGN CONFIRMATION AND A FORMAL RISK ASSESMENT SHALL BE CONDUCTED PRIOR TO FINALISATION OF THIS ARRANGEMENT.

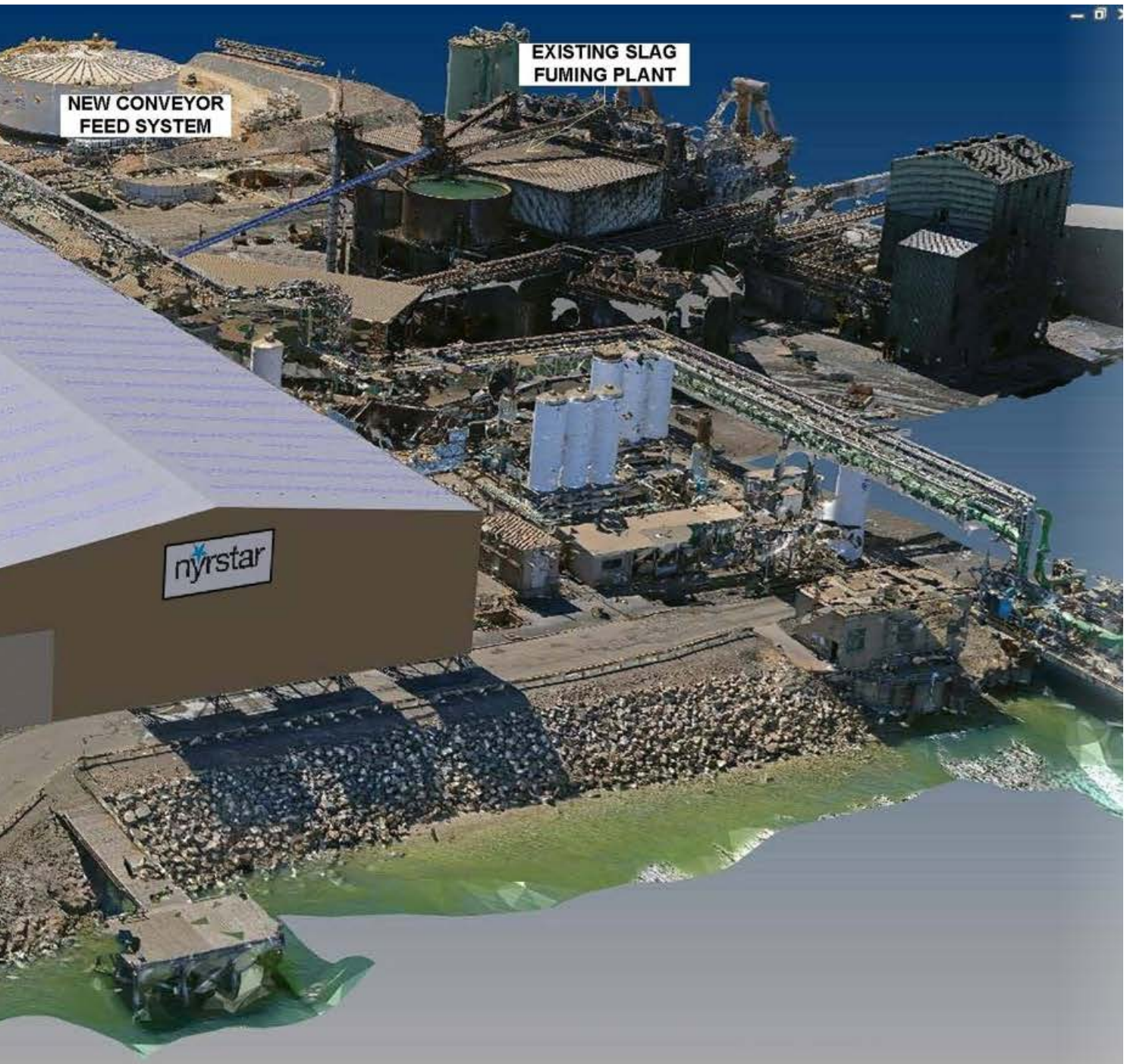

PERSPECTIVE VIEW
PROJECT_NEW PRODUCT RECYCLING FACILITY

PRELIMINARY INFORMATION ONLY

REV	DATE	REVISION DESCRIPTION	DRN	CHKD	DEGN	APPD	CLIENT
A	15/10/2021	ISSUED FOR CONCEPTUAL REVIEW	KTM	MK	KTM		

ALL DIMENSIONS IN mm U.O.N. X ± 0.5 ± 0.2/100 X.X ± 0.25 ± 0.2/100 X.XX ± 0.1 ± 0.05 X"X"X" ± 0.5 ± 16 EXCEPT SHOWN SEPARATELY UP TO 1000mm ± 2 OVER TO 1000mm ± 3 NON-CUMULATIVE X"X"X" ± 2/100		 3RD ANGLE PROJECTION UNLESS OTHERWISE NOTED DRAWN TO AS1900	 NYRSTAR PORT PIRIE A.B.N. 31 008 046 428 PO BOX 219 PORT PIRIE SA 5540 https://www.nyrstar.com/	DRAWN: KTM 15/10/2021 CHKD: MK 15/10/2021 DEGN: APPD: PROJECT No.:	PLANT PRODUCT RECYCLING FACILITY CONCEPT BUILDING PROPOSED SETTING CONCEPTUAL NORTH WEST VIEW	SCALE 1: 300	DRG No. SK-682-0001-04	REV. A
---	--	--	--	--	---	-----------------	---------------------------	-----------

TOTAL PART/ASSY MASS: 4628906.6 kg

The South Australian Property and Planning Atlas is available on the Land Services Website:
www.sa.gov.au/landservices



Scale ≈ 1:9028 (on A4 page)

250 metres≈

Address Details

Unit Number:
Street Number:
Street Name: ELLEN
Street Type: ST
Suburb: PORT PIRIE
Postcode: 5540

Property Details:

Council: PORT PIRIE REGIONAL COUNCIL
State Electorate: FROME (2014), FROME (2018)
Federal Electorate: GREY (2013), GREY (2016), GREY (2019)
Hundred: PIRIE
Valuation Number: 3525006054
Title Reference: CT6167/721
Plan No. Parcel No.: D12528A50

The information provided above, is not represented to be accurate, current or complete at the time of printing this report.

The Government of South Australia accepts no liability for the use of this data, or any reliance placed on it.

This report and its contents are (c) copyright Government of South Australia.



Government of South Australia
 Department of Planning,
 Transport and Infrastructure

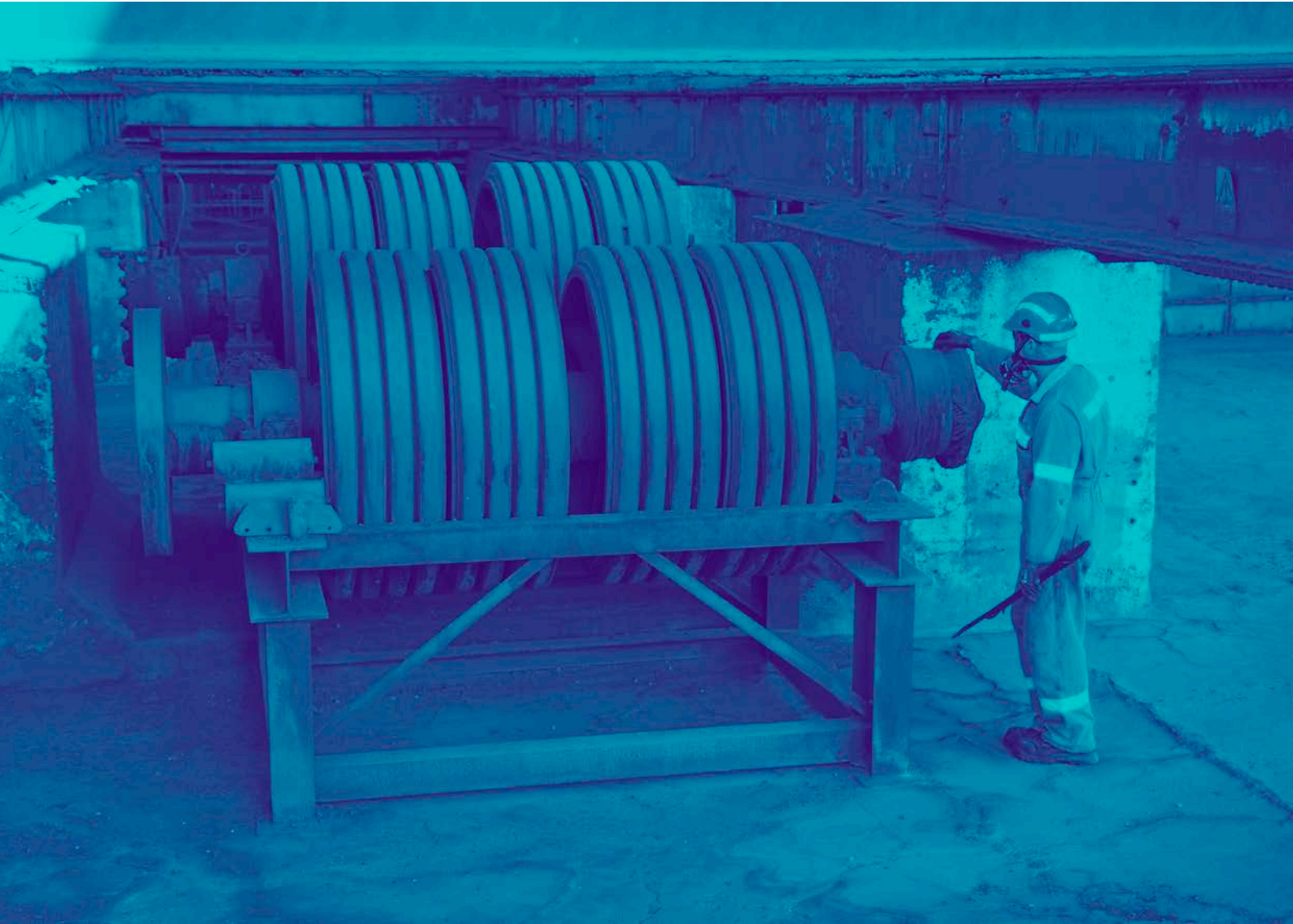

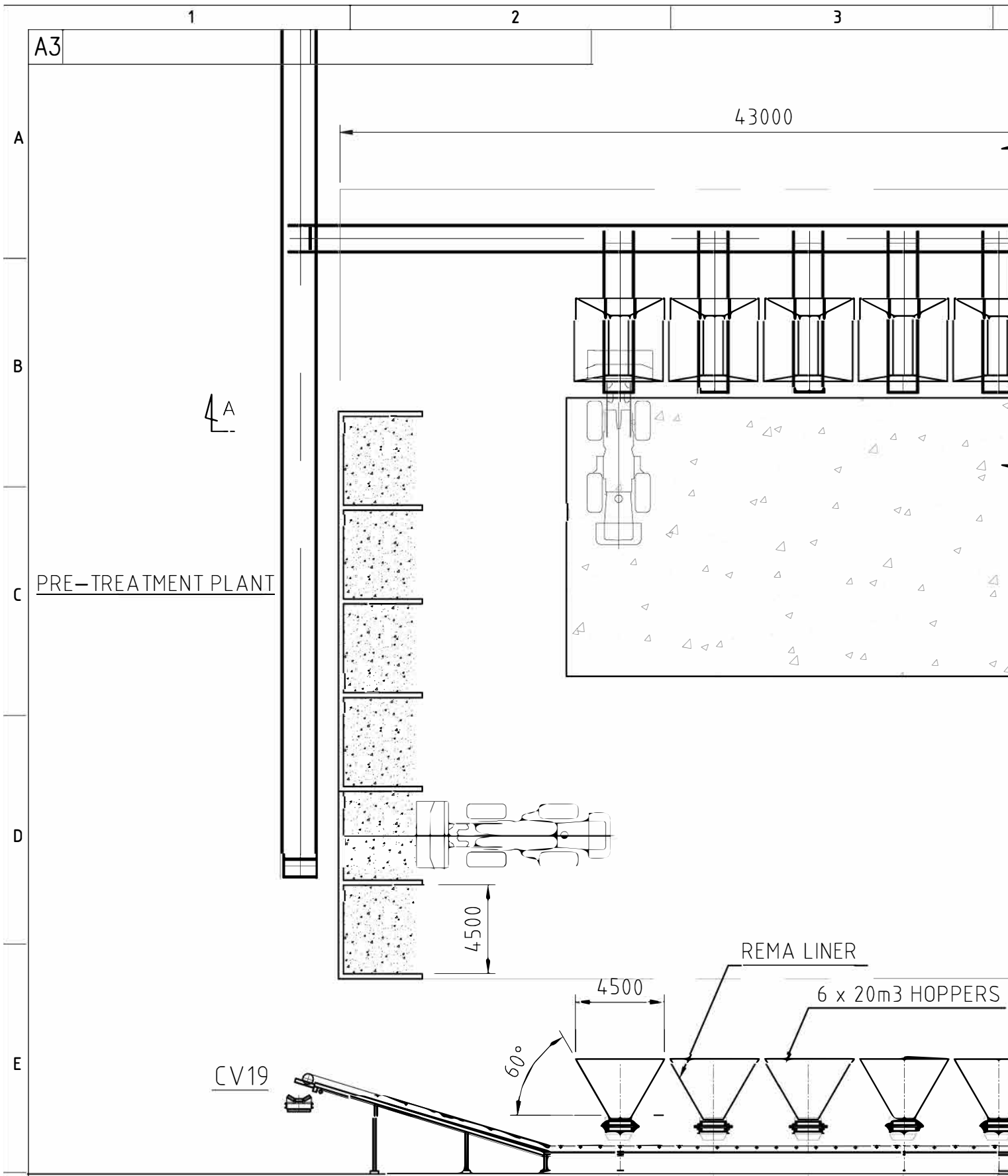

SECTION "A-A"

No.	DATE	REVISION DESCRIPTION	DRN	CHK	DES	APP	CLIENT
6							
1							
2							
3							

nyrstar port

P.O. BOX 219 PORT PIRRI
A.B.N. 31 008 046

4

5

6

A

B

C

D

E

F

A3

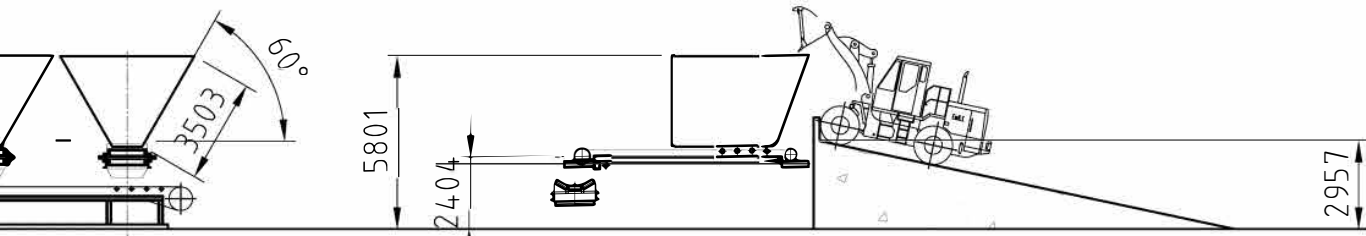
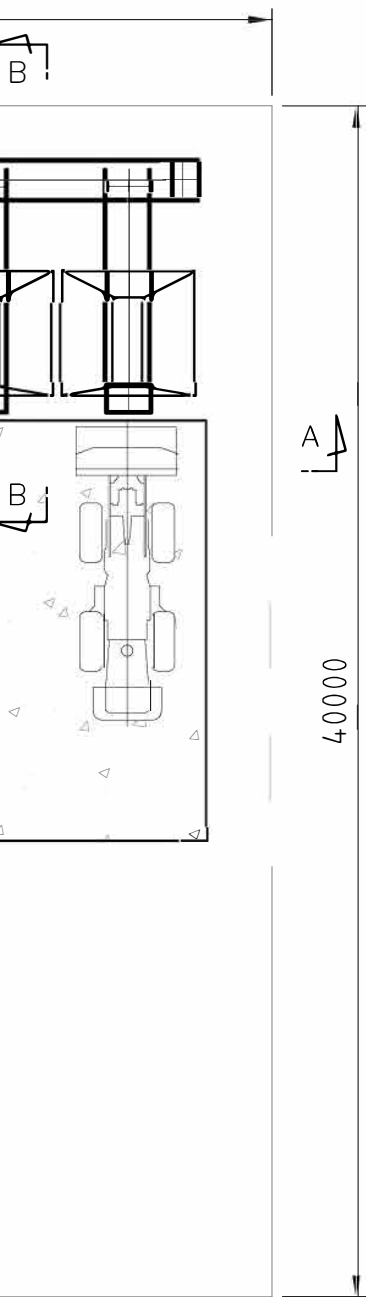

SECTION "B-B"



t pirie

E.S.A. 5540
428

DRAWN:	DATE:
CHECKED:	DATE:
DESIGNER:	DATE:
APPROVED:	DATE:
PROJECT:	

PLANT	
CONCEPT LAYOUT FOR PRE-TREATMENT PLANT	
SCALE:	DWG No
AS NOTED	REV

4

5

6

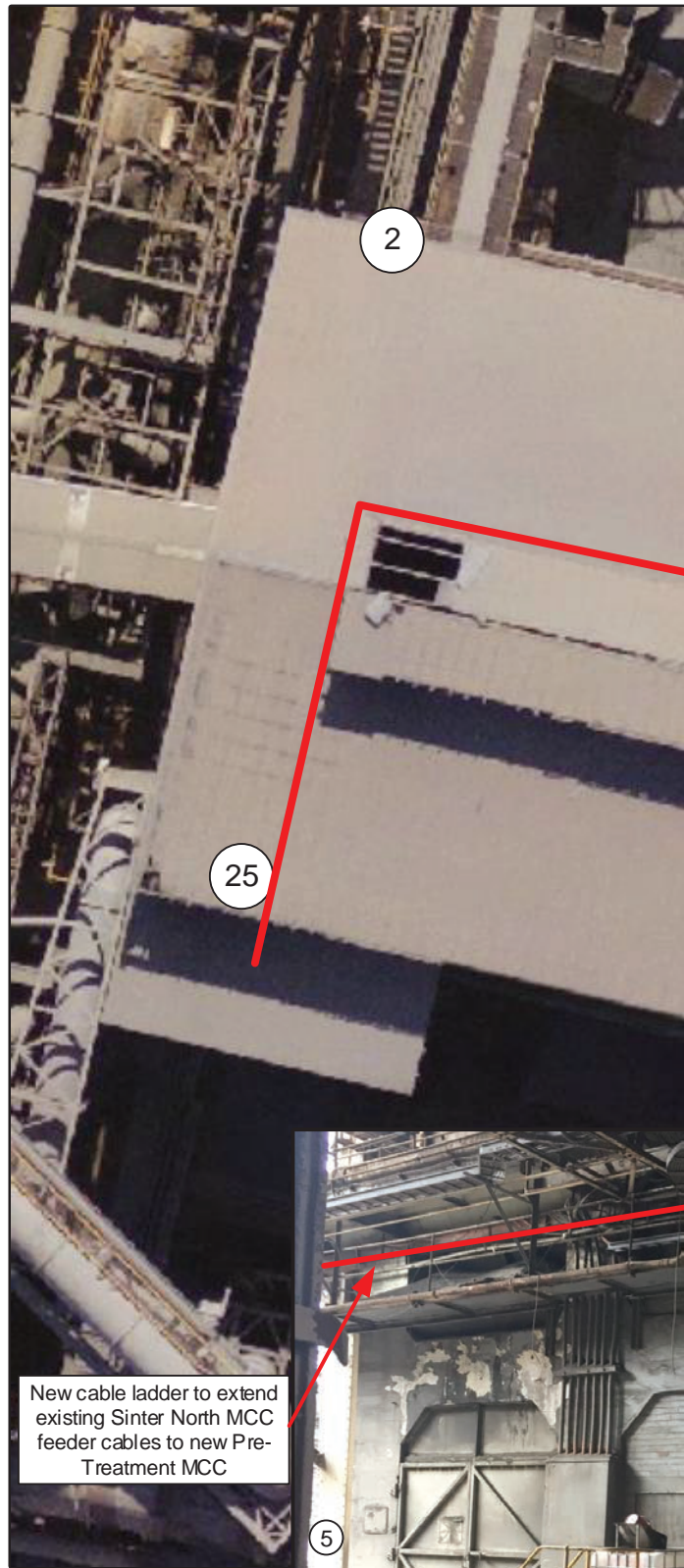
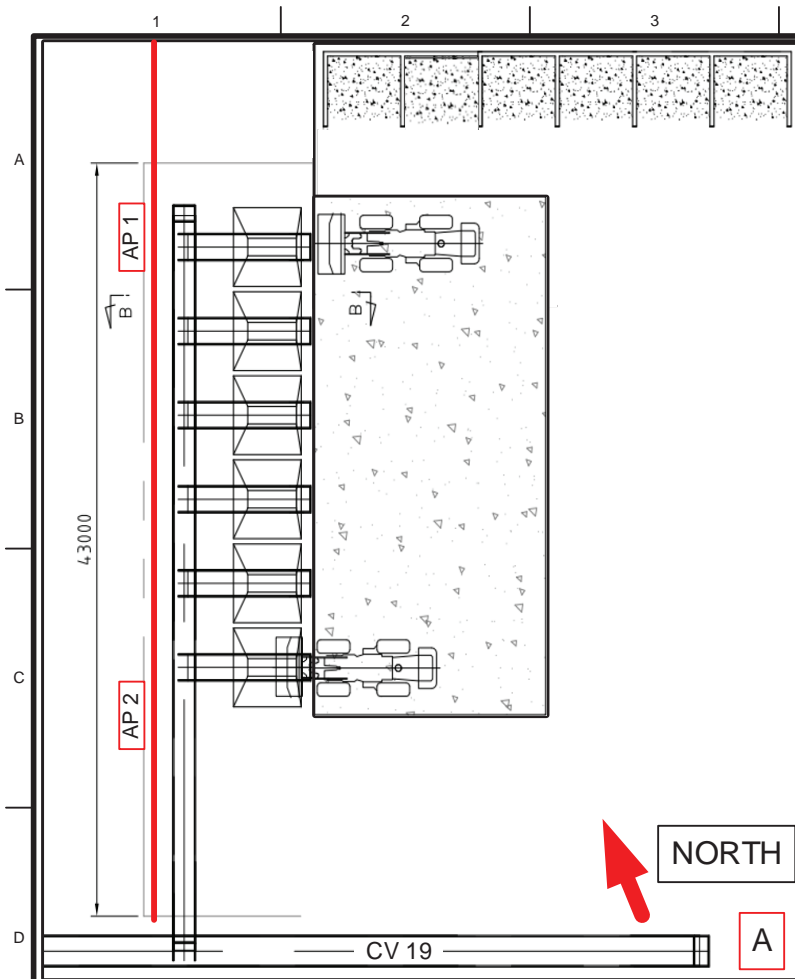

New cable ladder to extend existing Sinter North MCC feeder cables to new Pre-Treatment MCC

Alternate EER location

HIGH LEVEL SCOPE:

1. New EER proposed to be installed north of D&L Building. Due to flooding issues in the area, additional platforms may be required for personnel access from western end.
2. Existing Sinter North MCC feeder cables to be joined with new, and redirected along north wall of D&L Building in new cable ladder to new EER.
3. Proposed three main new arterial routes of new 600mm & 300mm cable ladders for new power and control cables from the new EER to key locations in the D&L Building.
4. From new cable ladder, new cables to transition to final end devices in existing cable ladder.
5. New Area Panels & Local Motor Isolator panels to be installed around new Feed System equipment.

ALTERNATE EER LOCATION:

1. Alternate EER location considered, west of the D&L Building column 5, in front of the conditioning drum spillage collection chute, see B.
2. Potential reduction in cable lengths and costs, however, the access doors would need to be relocated to the north facing wall.

Notes:

1. Cable routes proposed are indicative only and need to be confirmed during detailed design.
2. Assumed sufficient existing cable ladder installed around D&L Building for cable transitions from new cable ladders to final end devices.
3. Final EER location to be confirmed with Nyrstar during detailed design.
4. Final location of new Area Panels and Local Motor Isolator Panels to be confirmed during detailed design.
5. Alternate EER location not considered for purpose of estimating under the project Total Installed Cost (TIC) Estimate, 210562-EST-003.

No	DATE	DRN	CHK	ENG	QA	PROJECT	DESCRIPTION
0	12/08/21	GPA	JG	JC	RHL	CA/09000	Concept Design Only; Issued for Review CA/09000 (210562)
REVISION							

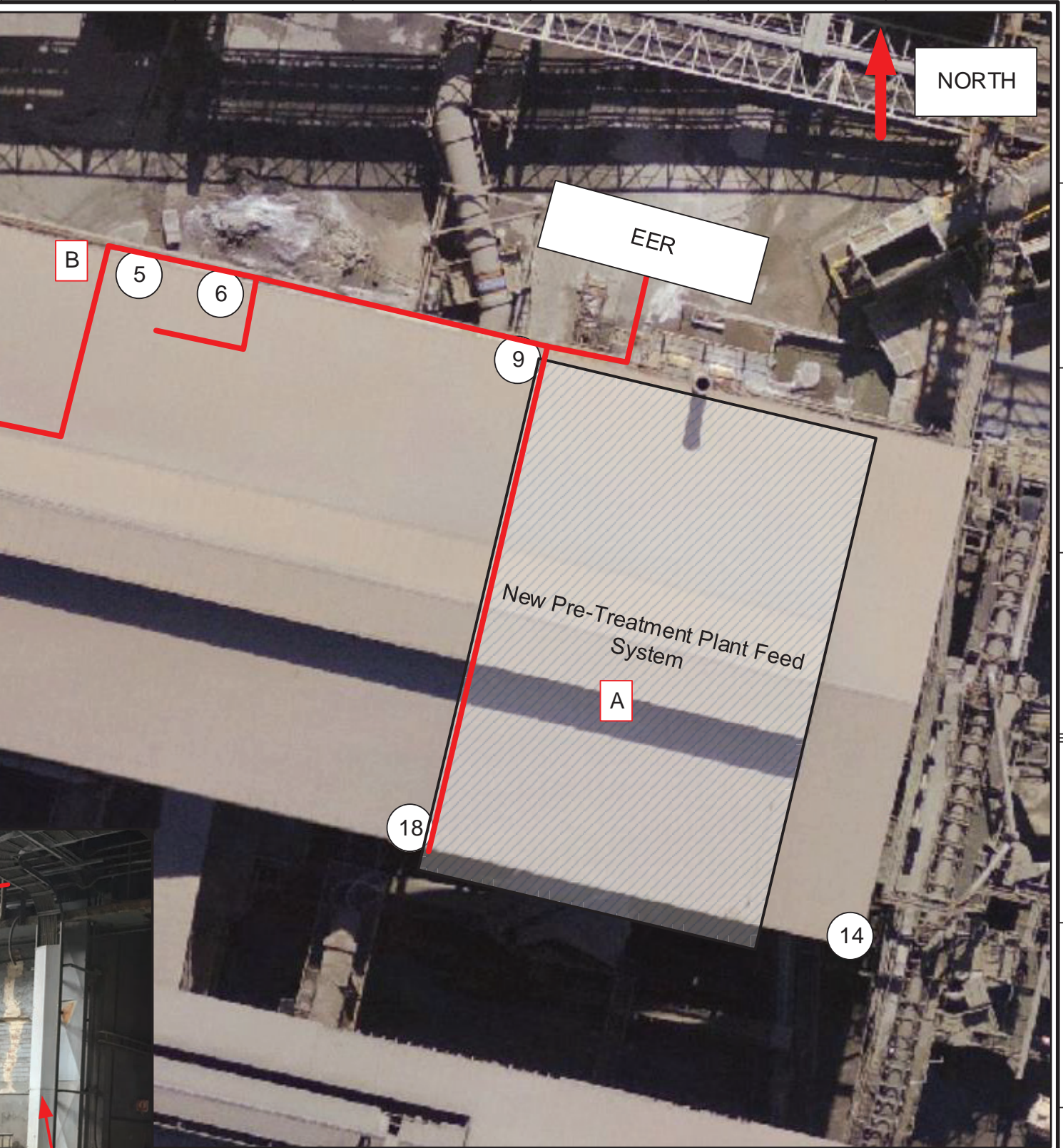

Legend:

- X - Indicates D&L Building Column number
- Proposed new cable ladder(s)
- AP x - New Area Panel



NUMBER		TITLE	
REFERENCE DRAWINGS			



www.gpaeng.com.au

**PRE-TREATMENT PLANT
LV EER
CONCEPT SITE LAYOUT**

DATE 02/08/2021	DRAWN GPA	CHK JG	ENG JC	QA RHL	SCALE NTS	REV A
PROJ No CA/09000	DRG No 210562-SK-002					



**Nyrstar Port Pirie
Dust Management Plan**

Licence Number EPA 775

Premises Address: 1 Ellen Street Port Pirie

Nyrstar Port Pirie Dust Management Plan

U-1189

775

A handwritten signature in black ink, appearing to be "M. J. ...", written over a horizontal line.

M19523

30 September 2020

September 2020

Contents

Contents	2
Glossary	3
1. Purpose	4
2. Scope	4
3. Measurement and Monitoring	4
4. Specification of Trigger Values	6
4.1. Trigger Values and Responses for Ambient Dust Monitoring Data	7
4.2. Trigger Values and Response for Meteorological Parameters	7
4.3. Trigger Values for Visual Observations	8
5. Detailed Action and Response Strategies	9
6. EPA Reporting	9
7. Public Access to Plan	9
Attachment 1. Current Trigger Action Response Plans	9

Glossary

Definitions and abbreviations of terms used to describe issues and performance measures used throughout this document are listed below:

TERM	DEFINITION
Fugitive Emission	Unplanned release of dust or fume or gas.
µg/m³	Micrograms per cubic metre. The unit of measure of both TSP from the High Volume Samplers and PM ₁₀ dust concentration recorded at the real-time dust monitors.
ppm	Parts Per Million
Real-Time Dust Monitor	A high dust concentration associated with a wind vector from the site triggers SMS and email alerts. All plant areas are required to identify and stop any dust sources and enter a report in the RIMS system. PM ₁₀ dust (particles less than 10 µm in size) is monitored using Tapered Element Oscillating Microbalances (TEOM) and Environmental Beta-Attenuation Mass (E-BAM) monitors.
RIMS	Risk Information Management System (RIMS) including incident, hazard and near miss reporting. Data is reviewed daily by all operational teams.
TARP	Trigger Action Response Plan utilised by plant areas to identify and respond to emission events.
Total Suspended Particulate (TSP)	The total amount of solid particulates suspended in the atmosphere.
Wind Rose Chart	A Chart that displays wind direction and speed. It indicates the percentage of time the wind blows from a direction within speed ranges.

1. Purpose

The Dust Management Plan provides a framework for dust (PM₁₀) alert triggers and action response plans, along with reporting on and review of the framework.

This Plan has been prepared consistent with the requirement of Condition U-1189 in EPA Licence 775.

2. Scope

The Plan has been developed in accordance with Condition U-1189 of EPA Licence 775, and includes:

- a. specification of trigger values to prevent and minimise particulate emissions from the Premises;
- b. specification of trigger values required by sub paragraph 2(a) of this condition should have regard to the following:
 - i. existing monitoring data;
 - ii. meteorological conditions; and
 - iii. visual observations;
- c. detailed action and response strategies that will be implemented when trigger values are reached;
- d. a methodology and framework for the provision of quarterly reports on the implementation of the Dust Management Plan to the EPA that includes, but is not limited to;
 - i. the date, time and trigger value exceeded;
 - ii. action and response strategies implemented; and
 - iii. a summary of events notified and reported to the public under condition U-1182;
- e. a methodology and framework for the provision of an annual report to the EPA which includes, but is not limited to:
 - i. a review of all trigger values identified in sub paragraph 2(a) of this condition;
 - ii. a review of the effectiveness of all action and response strategies identified in sub paragraph 2(c) of this condition;
 - iii. a trend analysis of data collected;
 - iv. a review and analysis of community complaints recorded in compliance with condition S-1 with the exceedance of trigger values reported under sub paragraph 2(d) of this condition; and
 - v. identified opportunities for improvement in dust management at the Premises.
- f. a methodology and framework for providing public access to the Dust Management Plan (or any revised plan approved by the EPA) and to quarterly and annual reporting.

3. Measurement and Monitoring

EBAM Monitors

Nyrstar Port Pirie has established a network of environmental beta attenuation mass (EBAM) monitors (refer Figure 2) that analyse particulates (PM₁₀ dust). The air quality data from the particulate monitors are used as triggers in Trigger Action Response Plans (TARPs).

The EBAMs are used in conjunction with visualisation software to provide real time PM₁₀ dust assessment onsite and offsite. The particulate monitors provide 360 degree coverage of wind direction (refer Figure 1). They increase the effectiveness of the TARP system by enabling rapid response to emission events irrespective of wind direction.

The EBAM network has capacity to help identify and quantify dust sources. As an indirect proxy for lead-in-air, this facilitates the scoping of improvement projects to address the most significant sources of lead-in-air on site and thereby assists in securing lower levels of lead-in-air and better protection of the health of Port Pirie children.

The EBAMs are used as TARP triggers but are not intended as compliance monitors and not calibrated to compliance standards because they are mainly located close to emission sources inside the site boundary.

The Boat ramp TEOM is the community dust monitor for compliance purposes. The EBAMs are, however, calibrated every two months to ensure reasonable accuracy. The EBAMs utilise a tape that is replaced every two to three months, depending on dust levels. The EBAM power boxes are serviced annually. Nyrstar has a spare power box to enable this servicing to occur without equipment downtime. Nyrstar conducts repairs, as necessary. The EBAMs are highly reliable and their operating time is expected to be greater than 95%.

The locations of the EBAMs will be reviewed quarterly to ensure that the monitoring network is effective. Before any proposed changes are made, a justification would be provided to the EPA for approval.

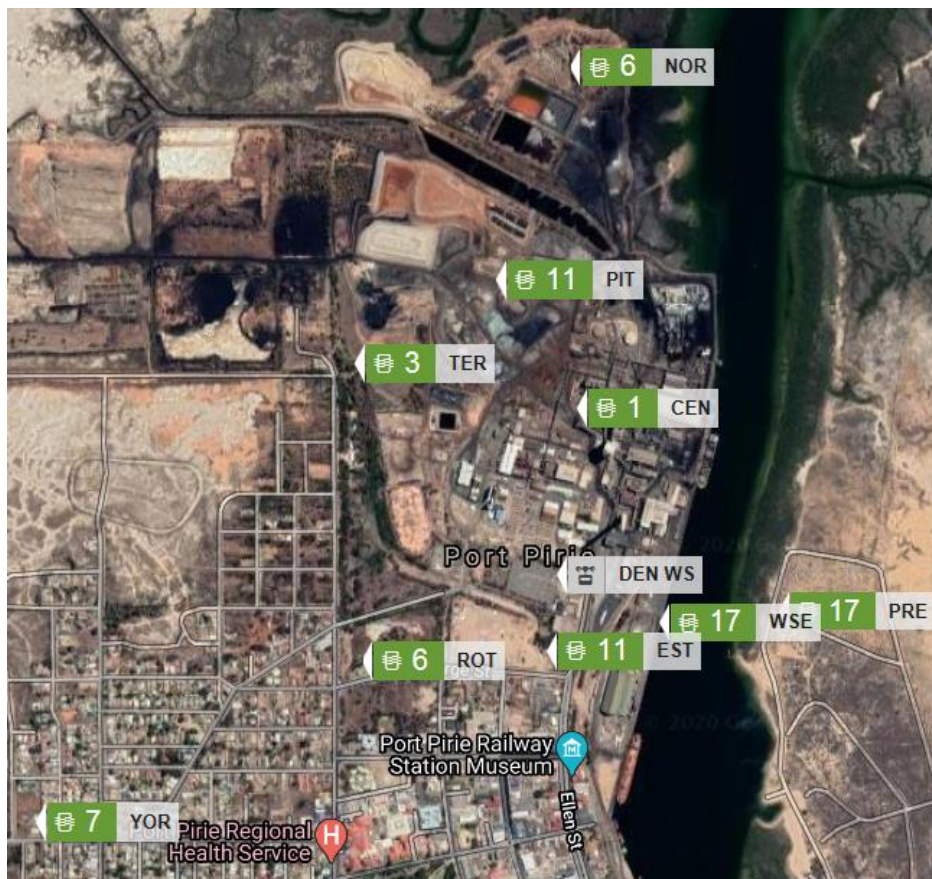

Figure 1: Location of onsite and near-site EBAM dust monitors

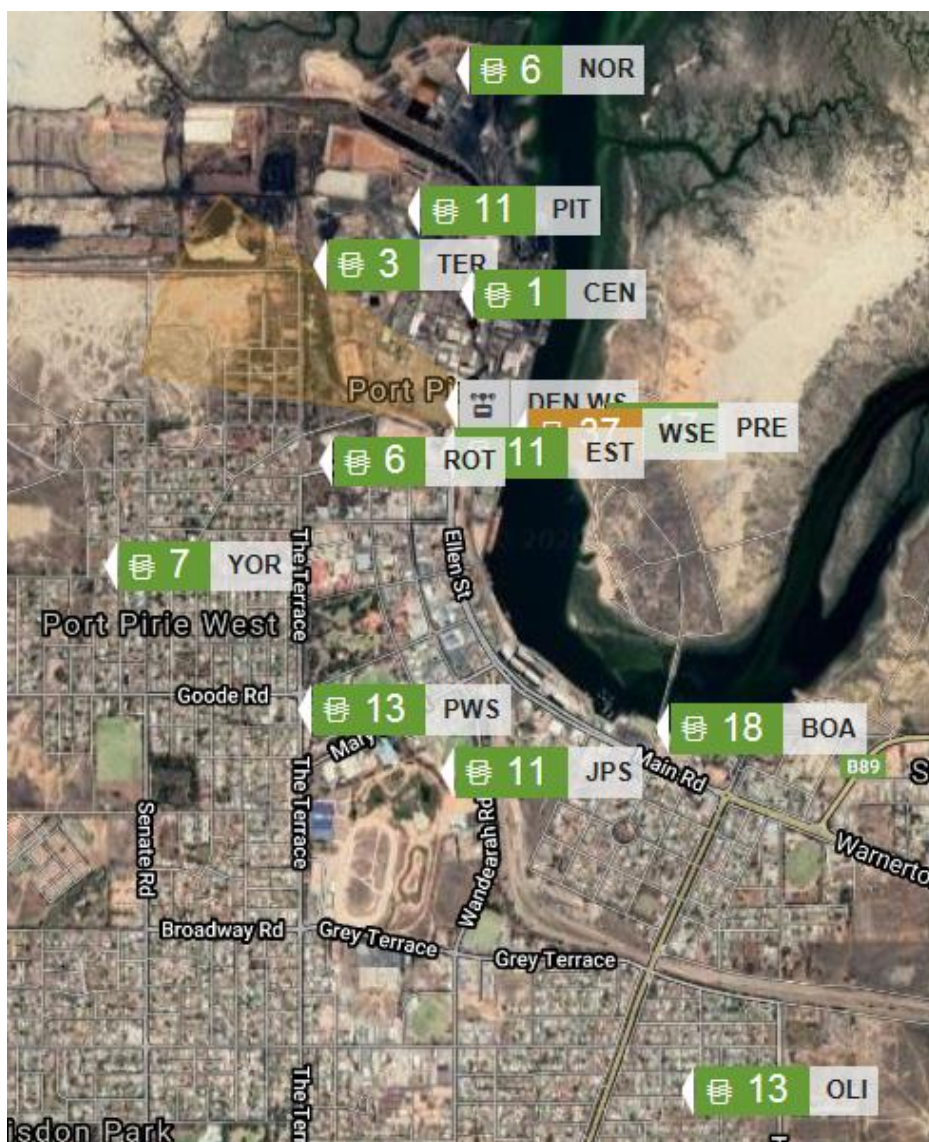

Figure 2: Current locations of EBAM dust monitors

4. Specification of Trigger Values

Triggers have been defined to assist Nyrstar to meet its dust management obligations by identifying circumstances when:

- Ground-level concentrations at offsite receptors are likely to be elevated due to activities onsite; and
- Activities onsite are generating dust outside of the normal range.

The following three levels of trigger/response have been defined:

1. Green – Normal Operations. Operators follow normal operating parameters and guidelines. They maintain routine housekeeping activities and hygiene equipment;
2. Amber – Medium Dust Risk. Operators identify and control emission sources, using plant-specific checklists that have been developed based on potential emission sources; and
3. Red – High Dust Risk. Operators identify and control emission sources, using the checklists. The incident is escalated to senior management to determine a commensurate response, such as shutting down the plant.

Triggers and responses have been defined for the following data sources:

- Ambient dust monitoring data;
- Meteorological parameters; and
- Visual observations.

4.1. Trigger Values and Responses for Ambient Dust Monitoring Data

The ambient particulate monitoring network is able to generate alerts when particulate levels exceed defined trigger values. The current alert trigger values are provided in Table 1 and Table 2. These trigger values have been set to achieve compliance with criteria in the Environment Protection (Air Quality) Policy in the community.

The particulate trigger values will be reviewed after six months, when sufficient data is available to enable statistical analysis. The selection of particulate trigger values will consider percentile values (i.e. 90th for green, 95th for amber and 99th for red) and their efficacy in achieving the Environment Protection (Air Quality) Policy criteria.

Alert Level	Particulate (PM ₁₀) Trigger Values, µg/m ³ (after background subtracted)
Amber	>100 & <200
Red	>200

Table 1 Particulate alert trigger values, over a 5-minute sampling interval

Alert Level	Particulate (PM ₁₀) Trigger Values, µg/m ³ (after background subtracted)
Amber	>50 & <100
Red	>100

Table 2 Particulate alert trigger values, over a 4-hour sampling interval

- To avoid alerts generated by background dust, the controls in Table 3 are applied to the monitoring data:
- The wind vectors that are able to generate alerts have been defined for each monitoring location; and
 - The particulate concentrate of wind blowing towards the site is subtracted from each of the monitor concentrations before they are compared to the alert trigger values.

Monitor Location	Alert Wind Direction (min° – max°)	Monitor for Background PM ₁₀
BOA	315-359	NOR
CEN	N/A	N/A
EST	290-359	NOR
JPS	340-10	NOR
NOR	135-225	135-180 --> OLI 180-225 -->YOR
OLI	330-350	NOR
PIT	135-225	135-180 -->OLI 180-225 --> YOR
PRE	290-350	NOR
PWS	350-45	NOR
TER	0-225	0-45 --> NOR 45-135 --> PRE 135-180 --> OLI 180-225 -->YOR
ROT	350-45	NOR
WSE	290-359	NOR
YOR	35-80	NOR

Table 3 Particulate alert wind directions and background monitors

The particulate alert trigger values, wind directions and background monitors are reviewed quarterly to ensure that the alerts are effective.

4.2. Trigger Values and Response for Meteorological Parameters

The trigger values in Table 5 are based on meteorological conditions that are known to have the potential to generate dust. The responses that are triggered by exceeding the values in Table 5 are presented in Table 6 and are proactive based on forecast meteorological conditions.

Receiver	Source	Main Wind Range	10 degree Margin	20 degree Margin
Boat Ramp	General Plant Area	310 – 10	300 or 20	290 or 30
	Pit	330 – 350	320 or 360	310 or 10
Pirie West	General Plant Area	10 – 90	360 or 100	350 or 110
	Pit	300 – 60	290 or 70	280 or 80
General Site	General Plant Area	0 – 360	NA	NA
	Pit	240 - 340	230 or 350	220 or 360

Table 4 Table of wind direction ranges by receiver and source

Temperature, °C	Wind Direction, degree	Wind Speed			
		0-9 km/h	10-19 km/h	20-29 km/h	30+ km/h
<30	Main wind range	Low	Moderate	High	Extreme
<30	10 degree margin	Low	Low	Moderate	High
<30	20 degree margin	Low	Low	Low	Moderate
<30	30 or more margin	No Rating	No Rating	No Rating	No Rating
30 – 34.9	Main wind range	Low	Moderate	High	
30 – 34.9	10 degree margin	Low	Low	Moderate	High
30 – 34.9	20 degree margin	Low	Low	Low	Moderate
30 – 34.9	30 or more margin	No Rating	No Rating	No Rating	No Rating
35+	Main wind range	Low	Moderate	Extreme	Extreme
35+	10 degree margin	Low	Low	High	High
35+	20 degree margin	Low	Low	Moderate	Moderate
35+	30 or more margin	No Rating	No Rating	No Rating	No Rating

Table 5 Table of dust risk rating by temperature, wind direction and wind speed

Dust Risk Forecast Rating	Action Required	Responsibility
Low (Green) & No Rating (Blue)	Housekeeping – spillage control & removal.	Plant Superintendents
Moderate (Yellow)	Prior cleaning and watering of site areas. Dust suppression (water sprays, fog cannon, hose & sprinklers) Mobilising water & street sweepers to clean areas.	Plant Superintendents
High (Amber) & Extreme (Red)	Deferring any planned tasks and activities likely to generate dust. Secure product storage – i.e. ensuring fume storage shed doors are closed.	Plant Superintendents

Table 6 Actions and responses for meteorological data triggers

4.3. Trigger Values for Visual Observations

Table 7 presents visual observation triggers and the corresponding trigger actions are included in the TARPS, refer Attachment 1. Current Trigger Action Response Plans.

Alert Level	Trigger
Green – Normal Operations	General build-up of deposited dust on non-work related areas at the Facility, e.g. carparks, alongside buildings etc.
Amber – Medium Dust Risk	Visible dust plume generated by Facility activity above normal/acceptable levels.
Red – High Dust Risk	Visible dust plume crossing the Facility boundary.

Table 7 Visual observation alert triggers

5. Detailed Action and Response Strategies

Trigger action response plans (TARPs) have been developed for the main plant areas, refer Attachment 1. Current Trigger Action Response Plans:

- Primary Smelter;
- Blast Furnace;
- Slag Fumer & Kilns;
- Refinery; and
- Materials handling is under development. Currently a high-wind protocol is utilised to plan material movement activities. This TARP will be provided to the EPA when available.

The TARPs describe the checks that plant operators will undertake when then receive a particulate alert. These checks of plant conditions will enable emissions sources to be identified and controlled as quickly as possible. The completed TARP checklists provide evidence of the plant operator responses to each particulate alert. It is anticipated that the checklists would take up to 30 minutes to complete.

The copies of the current TARPs are included in Attachment 1. The documents are reviewed quarterly to ensure that they are effective.

6. EPA Reporting

The EPA are notified by email when a Red particulate alert is triggered.

An overview of Dust Management Plan implementation is provided in quarterly and annual environment reports submitted to the EPA. The content of the report overviews are detailed in Table 8. Quarterly reports are prepared within fifteen days after each 30 September, 31 December and 31 March. The fourth quarter is included in the annual report. The annual report (July to June) is prepared by 31 August.

Report	Overview Content
Quarterly Report	i. The date, time and trigger value exceeded; ii. Action and response strategies implemented; and iii. A summary of events notified and reported to the public under the Nyrstar Port Pirie Ground Level Particulate and Sulphur Dioxide Monitoring and Reporting Plan, EPA licence condition U-1182.
Annual Report	i. A review of all trigger values identified in Section 4; ii. A review of the effectiveness of all action and response strategies identified in Section 5; iii. A trend analysis of data collected; iv. A review and analysis of community complaints recorded with the exceedance of trigger values recorded in the quarterly reports; and v. Identified opportunities for improvement in dust management at the premises.

Table 8 Content of quarterly and annual report overviews

7. Public Access to Plan

The EPA accepted Dust Management Plan is available by request from the <http://nyrstarportpirie.com.au/Reporting.php> website, along with the most recent quarterly and annual environment reports.

Attachment 1. Current Trigger Action Response Plans

Pre Treatment Facility Dust Risk Management Trigger Action Response Plan (TARP)

Scope/Instructions

Normal Operation	Trigger	Operator Action	Plant Status
	<ul style="list-style-type: none"> Southerly winds (between 60° and 300°, clockwise); No Emissions reported; and Particulate Alarm Status Green. 	<ul style="list-style-type: none"> Review Wind Direction and Forecast twice per Shift; Review Emissions Cameras every 2 hours; Follow Normal Operating Parameters And Guidelines: Document PW-025-00037; and Maintain Routine Housekeeping Activities. 	<ul style="list-style-type: none"> Pre Treatment Facility remains On-Line.
Medium Dust Risk	Trigger	Operator Action	Plant Status
	<ul style="list-style-type: none"> Northerly winds (between 0° and 60°, clockwise) with Speed less than 5.5m/s⁽¹⁾; or Northerly winds (between 300° and 360°, clockwise) with Speed less than 5.5m/s⁽¹⁾; or Visible Emission from Plant; or Particulate Alarm Status Amber; or Lead in Air Analyser at Dental Clinic is above 4,000 ng/m³ (1h sample time). 	<ul style="list-style-type: none"> Ensure water sprays and fog canons are ON; Review Operational Parameters And Critical Processes For Emissions: Document PW-080-00054; Escalate to Team Leader and Superintendent. Increase Monitoring – Operators to increase the frequency of Plant Inspections (every 20min); Review Emissions Cameras every hour; and SPL Respond to Particulate Alarms: PW-702-00003. 	<p>Pre Treatment Facility remains On-Line, with Team Leader Review.</p> <p>De-Escalate if:</p> <ul style="list-style-type: none"> Process Stable; Confirmed no Plant Emissions; Clarified position with Team Leader and/or Superintendent; and Forecast Wind Direction for next 6-hours favorable (Southerly).
High Dust Risk	Trigger	Operator Action	Plant Status
	<ul style="list-style-type: none"> Northerly winds (between 0° and 60°, clockwise) with Speed consistently greater than 5.5m/s⁽¹⁾; or Northerly winds (between 300° and 360°, clockwise) with Speed consistently greater than 5.5m/s⁽¹⁾; or Plant Emissions cannot be controlled within 20min; or Community Complaint regarding Dust or SO₂ Emissions; or Particulate Alarm Status Red in combination with visible plant emissions or Lead in Air Analyser at Dental Clinic is above 6,000 ng/m³ (1h sample time) in combination with visible plant emissions 	<ul style="list-style-type: none"> Escalate to Plant Superintendent/Manager and review the need to shut down or slow the Plant; Review Forecast – if expected to be Off-Line for over 12 hours, Run Machine Out; Operators to use Hoses to wet down Plant Areas, focusing on loose/fine Dust, open Areas/Roads and Spillage Areas; and Review Cameras. 	<ul style="list-style-type: none"> If already Off-Line, obtain Superintendent/Manager approval before starting plant. <p>De-Escalate if:</p> <ul style="list-style-type: none"> Particulate Alarm Status Green; Wind Direction consistently between 60° and 300° or Wind Speed less than 3m/s; Wind Forecast favourable for next 6-hours (Southerly); and Completed PF-028-00989.

Notes: (1) The Wind Speed is available on the Production Information (PI) System.
An indicator of high winds is Dust being lifted off the ground.

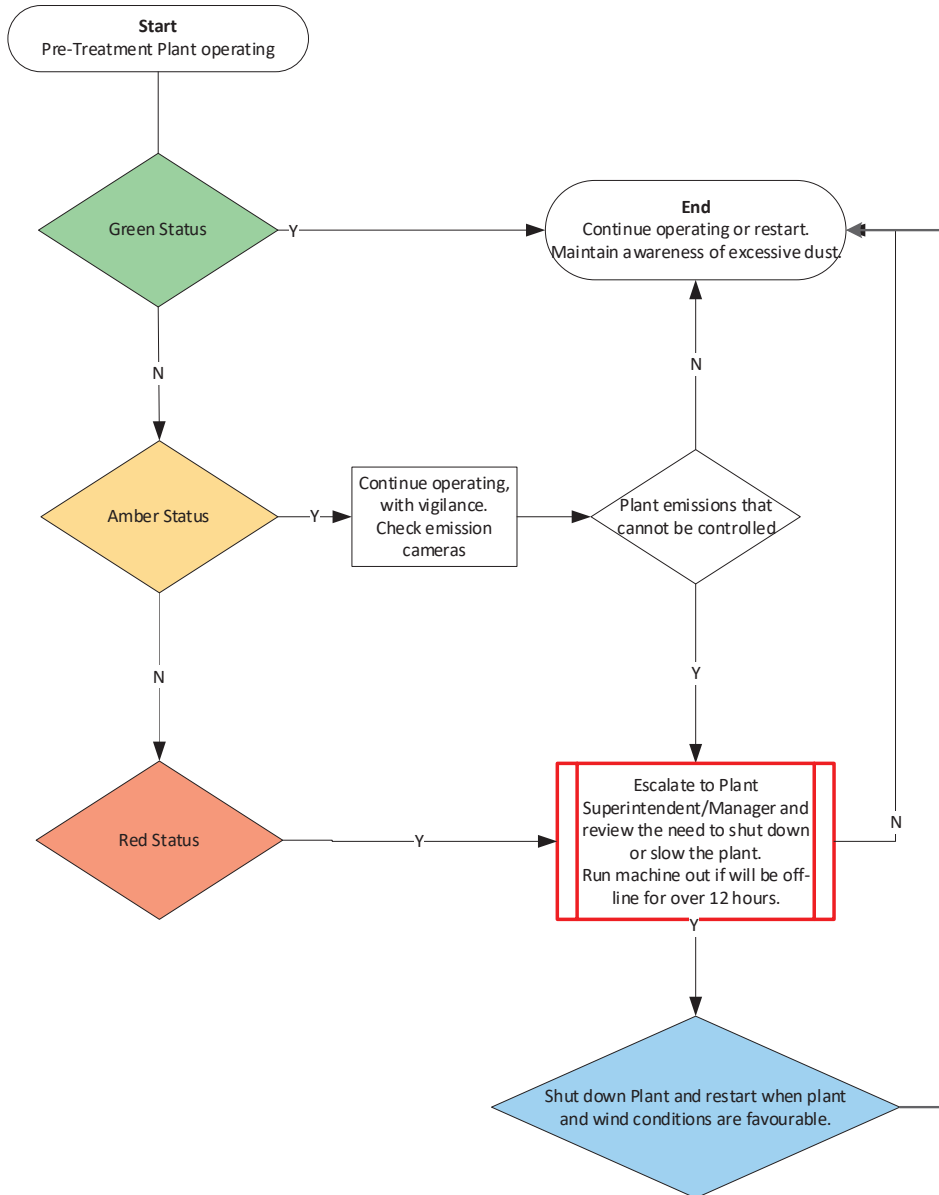

Trigger Action Response Plan for Materials Handling

DUST ALERTS

Alert Level	Triggers	Response
Green Normal Operations	<ul style="list-style-type: none"> No visible emissions; and Particulate alarm status green. 	<ul style="list-style-type: none"> Follow normal operating parameters and guidelines; Maintain routine housekeeping activities; and Maintain Fog Cannons, Watercarts, Road Brooms, Paper Mache.
Amber Medium dust risk	<ul style="list-style-type: none"> Visible emissions from Materials Handling tasks; or Particulate alarm status amber. 	<ul style="list-style-type: none"> Identify sources and control emissions, refer below; Notify Superintendent and Manager of status; and Complete the MH TARP checklist for each alert. Report an unsafe condition in RIMS for the shift and attach all checklists to it (both amber and red).
Red High dust risk	<ul style="list-style-type: none"> Visible emissions from Materials Handling tasks; Uncontrollable emissions from Materials Handling; Particulate alarm status red. 	<ul style="list-style-type: none"> Contact Superintendent for approval to stop task/s. If Superintendent is not available, contact the Manager. Complete the MH TARP checklist for each alert. Report an unsafe condition in RIMS for the shift and attach all checklists to it (both amber and red). If Materials Handling task/s are stopped, restart when: <ul style="list-style-type: none"> Major emission causes have been addressed; and Wind conditions have changed to an acceptable level.
Key Controls and Tools <ul style="list-style-type: none"> The primary dust alert communication is a text from the Envirosuite system to the Team Leader mobile phone (0439 304 592) which is to be carried by the Team Leader at all times. An email will also be sent to the Operations Coordinator and Contract Coordinator as a back-up. Review Dust Risk Forecast (received daily by email). Follow High Dust Risk Notification PRI-701-00013 and particulate alarms process PP-400-00010; Ensure Avigilon camera network accessible from Coordinators Office and the Hazell Bros Office; Refer to emissions controls in PW- Key Material Handling controls: <ul style="list-style-type: none"> Identify any change in the activities or site conditions contributing to emissions; Supervisor to inspect tasks and associated equipment; and Fog Cannons, Water Sprays, Watercarts, Road Brooms and Paper Mache all to be utilised when possible 		

Dust Alert Response Checklist – Materials Handling

Team Leader	Date of dust alert	Time of dust alert

CHECK ITEM	OK	NOT OK	CORRECTIVE ACTION
Check Pit Activities.			
Check Watercarts and Road brooms are operational and prioritise areas they are working in			
Check Battery Bay sprays			
Check TSL Caster Bunker sprays			
Check PGP Stockpile			
Check LSLC Stockpile			
Check BuLP Stockpile			
Check CT Shed and Wharf carting activities if applicable			
Check Fog Cannons are in use			

Instructions:

- (1) When dust alert is received this checklist is to be completed as soon as reasonably practicable.
- (2) After any required corrective actions have been made, an environmental unsafe condition in RIMS is to be raised and this checklist scanned and attached to the RIMS. Any additional alert checklists for the shift should be added to the same RIMS.
- (3) Ensure that the RIMS has the "Environment" box selected.

PLANT EMISSION TRIGGERS

Triggers	Response	Reporting
High Wind forecast	Site Manager, Operations Coordinator and Supervisor to plan suitable tasks and cease high risk tasks	Site Manager and Operations Coordinator
Visible emissions	Stop task and attempt to control task using Fog Cannon, Watercart or other	Operators report to Supervisor



Port Pirie 2022 Variation

Air Quality Modelling Assessment for Pre-treatment Plant

Nyrstar Port Pirie

04 April 2022

→ **The Power of Commitment**



GHD Pty Ltd | ABN 39 008 488 373

180 Lonsdale Street, Level 9

Melbourne, Victoria 3000, Australia

T +61 3 8687 8000 | F +61 3 8732 7046 | E melmail@ghd.com | ghd.com

Document status

Status Code	Revision	Author	Reviewer		Approved for issue		
			Name	Signature	Name	Signature	Date
S3	Draft A						21/12/2021
S4	0	Yvonne Lim	Barry Cook		Mark Koller		22/12/2021
S4	1	Yvonne Lim	Barry Cook		Michael Asimakis		04/04/2022
[Status code]							
[Status code]							

© GHD 2022

This document is and shall remain the property of GHD. The document may only be used for the purpose for which it was commissioned and in accordance with the Terms of Engagement for the commission. Unauthorised use of this document in any form whatsoever is prohibited.

 **The Power of Commitment**

Executive summary

GHD was engaged by Nyrstar Port Pirie (Nyrstar) to undertake an air quality impact assessment for the proposed pre-treatment process of materials to use in the blast furnace. Assessment was undertaken by GHD on predicted Lead-in-Air (LIA), other metals (such as arsenic, cadmium and zinc) and PM₁₀ from the proposed operation for the following scenarios:

- Scenario 1a_1: Pre-treatment with stockpiles (Start)
- Scenario 1a_2: Pre-treatment with stockpiles (18 months)
- Scenario 1b: No pre-treatment and no stockpiles (including Product Recycling Facility)
- Scenario 2: No pre-treatment with stockpiles (Current operations)
- Scenario 3: Pre-treatment trial

Methodology

Meteorology

GHD utilised local meteorology from the Nyrstar operated 'Dental Clinic' and 'Boat Ramp' Automatic Weather Station (AWS) for the time span of 1 January 2009 to 31 December 2011 inclusive. The first year of the period is recommended by EPA to be the 'most representative' year across all the climatic zones of South Australia. However, the winter-time winds in Port Pirie during 2009 were found to have excessive northwest quadrant winds inconsistent with the long-term climate. Hence, a longer (three year) period was used to ensure worst case meteorological conditions are included in the modelling.

TAPM prognostic model was run for the years 2009 to 2011 to obtain a coarse three dimensional meteorological gridded dataset for Port Pirie Pre-treatment plant for the selected model period. In addition, the model was used to provide an initial guess field. A CALMET simulation was then set up to run for the model period, utilising the three-dimensional gridded data output from TAPM to resolve the wind field around the site to a 500 m spatial resolution.

Dispersion modelling

Dispersion modelling was conducted to predict the maximum ground level concentrations resulting from emissions from the industrial site using CALPUFF.

The various types of emissions from onsite processes that result in offsite impact can be categorised as follows:

- Stack sources
- Plant fugitive sources
- Stockpile sources
- Vehicle sources

Details of emission have been taken from data provided by Nyrstar, as follows:

- Stack emissions have been based upon tests conducted onsite by Assured Environmental (AE) and provided in the NPI reporting data. These emissions represent the averages of the resulting data, along with operational efficiencies of the various plants. Where no operational times have been given, the plant efficiencies have been assumed to be 100%, (i.e. operating all hours of the year).
- Plant fugitive emissions were based upon the operational efficiencies of each plant and the data provided in the draft 2019 NPI report. Where percent time was included for emissions from field investigations in the NPI report, emissions were averaged across the operational times of the respective plants.

A worst-case scenario had been assumed for all pollutants and modelled for all hours of the years 2009 to 2011. GHD applied a monthly normalisation factor to best represent real-time observed emissions being dispersed to result in observed measured impacts. The derived normalisation factors were applied to point sources, fugitive sources and stockpile sources based on the assumed (conservative as modelled) emission rates and measured real-time LIA data provided by Nyrstar.

A normalisation factor was applied to reduce model errors where some months are:

- Underpredicted (two months) due to inherent limitations in the emission inventory and variable dispersion due to meteorology.
- Overpredicted (34 months) due to the conservative nature of the emission inventory where plant, operations and other sources are always on. The combination of emissions factors being high and the dispersion meteorology for that month produces modelled data which are higher than reality (as measured).

Of the 5 scenarios, Scenario 2 was taken as the base-case scenario as it remains the most representative of current operations undertaken at Nyrstar Port Pirie. A comparison of the remaining scenarios was taken against the base-case scenario to present predicted impacts for the implementations of the pre-treatment process.

Results

LIA predicted impact – base-case (Scenario 2)

Monitored data for LIA was provided at Ellen Street, Boat Ramp and Oliver Street. Together with the Pirie West Primary School site, these four monitoring locations, while located close to the facility sources, essentially representative of the facility's impact on ambient concentrations. The Ellen Street represents boundary conditions, and therefore would be expected to have the highest predicted (and measured) concentrations while Boat Ramp, Oliver Street and Pirie West Primary School are representative of community exposure.

Q-Q plots were used to compare the monthly results at each monitoring location after the application of the monthly factored emissions for the base-case scenario (the closest representation to plant operations at the time of the measurements).

The general pattern of the modelled results sees the model slightly over predicting the total concentration at locations closer to the site (Ellen Street and Boat Ramp), while underprediction occurs at locations further from the site (slightly for Oliver Street and Pirie West Primary School). The Pirie West Primary School has the greatest underprediction as it is downwind of the site operational sources the least of the four sites. Winds east of north are required to bring site emissions to the Primary school while the other three sites are impacted by site emissions when winds are west of north. As the Primary School is an outlier to the other three sites, the predictions are less accurate for this site and suggests that a source other than the operational sources is contributing. The unknown background source could be legacy lead from many years of smelter operations or other unidentified contributors.

The under or over prediction does not impact greatly the methodology of comparing scenarios at each site. While the absolute amount of LIA at each site will change between scenarios, the difference expressed as a percentage change from the base-case is independent of the degree of over or under prediction.

EPA licence

EPA has specified limit and target exceedance criteria for LIA at several locations near Nyrstar Port Pirie. The predicted LIA concentration for the scenarios modelled over the 2009 to 2011 modelled period is compared against the exceedance criteria in Table 1. The limits and targets are based on measured ambient concentrations rather than predicted values. All locations and averaging periods are modelled to be within the licence criteria. A conclusion is made that the base-case modelling is a fair reflection of the plant impact on the surrounding community locations. It then follows that Scenario 1 (a and b) have lower predicted impacts at the licence locations.

The average concentrations for S3 in Table 1 were calculated from monitoring data up to 30 September 2021. The predicted scenarios (S1 variations and S2) show the changes in average concentrations as modelled, based on the changes of each scenario inventory from the Pre-Treatment Trial scenario (S3).

Table 1 Predicted concentrations 12-month and 3-month averaged (Monitoring data at 30 September 2021)

Averaging period	Location	Licence criteria ($\mu\text{g}/\text{m}^3$)	Predicted concentrations ($\mu\text{g}/\text{m}^3$)				
			S1a_1	S1a_2	S1b	S2	S3
Rolling 3 month average	Oliver Street	0.45	0.39	0.36	0.30	0.42	0.42
	Pirie West Primary School	0.45	0.34	0.31	0.26	0.37	0.38
	Ellen Street	2.2	1.99	1.81	1.45	2.11	2.17
	Boat Ramp	1.0	0.72	0.66	0.60	0.78	0.78
12 month (calculated half-yearly)	Ellen Street	1.6	1.40	1.31	1.08	1.53	1.53
	Boat Ramp	0.6	0.50	0.46	0.42	0.54	0.54
12 month (calculated quarterly)	Oliver Street	0.4	0.25	0.23	0.20	0.27	0.27
	Pirie West Primary School	0.4	0.28	0.26	0.22	0.31	0.31

Scenario testing

Of the predicted concentrations for the four scenarios in comparison to the base-case scenario, the general trend shows:

- A decrease in predicted concentrations for scenario 1a_1, 1a_2 and 1b subsequently, for PM₁₀, Lead and Zinc at all monitoring sites.
- Similar predicted concentrations for scenario 1a_1, 1a_2 and 1b, for Arsenic and Cadmium at all monitoring sites.
- An increase in predicted concentration for scenario 3 for all species at all monitoring sites.

The small decreasing trend predicted concentrations from the base-case scenario to 1a_1 indicates that implementation of the Pre-treatment Plant operations may result in slightly decrease concentrations of arsenic, cadmium, PM₁₀, lead and zinc in the atmosphere. The further slight decrease from scenario 1a_1 to 1a_2 indicates that after 18 months there will be a predicted further decrease in monthly concentrations for all species in the atmosphere.

The decreased predicted concentrations for scenario 1b in the longer term excludes the emissions from the Pre-treatment Plant as well as stockpiles.

Figure 1 to Figure 20 display the box plots comparisons of the five scenarios all modelled species at all locations.

Arsenic

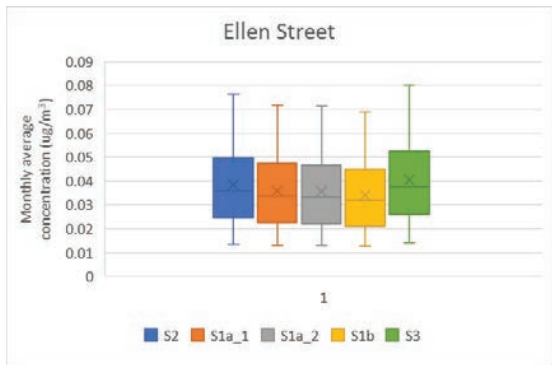

Figure 1 Ellen Street - Arsenic monthly average concentration box plot

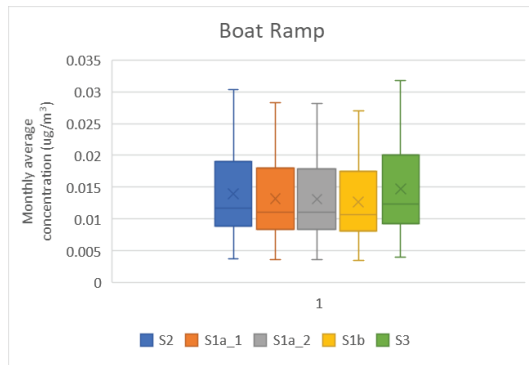

Figure 2 Boat Ramp - Arsenic monthly average concentration box plot



Figure 3 Oliver Street - Arsenic monthly average concentration box plot

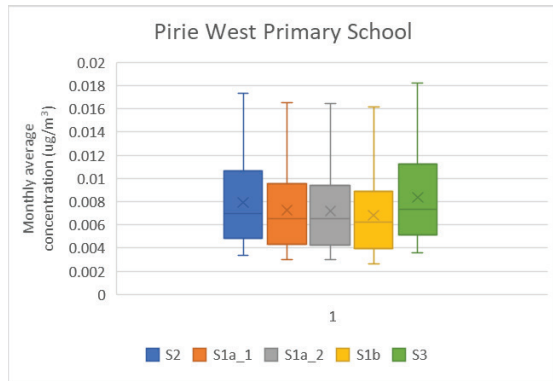

Figure 4 Pirie West Primary School - Arsenic monthly average concentration box plot

Cadmium

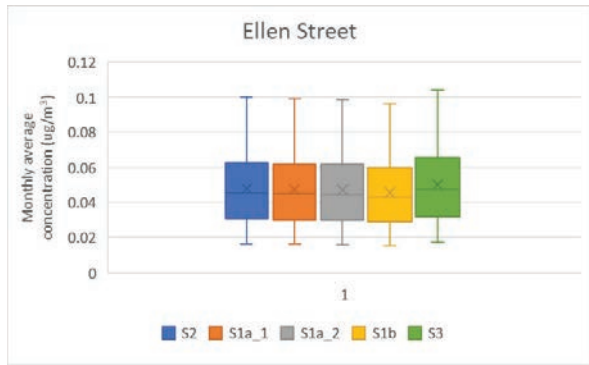

Figure 5 Ellen Street – Cadmium monthly average concentration box plot

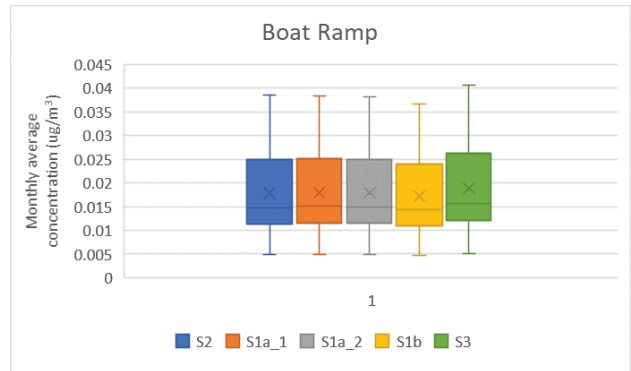

Figure 6 Boat Ramp – Cadmium monthly average concentration box plot



Figure 7 Oliver Street – Cadmium monthly average concentration box plot

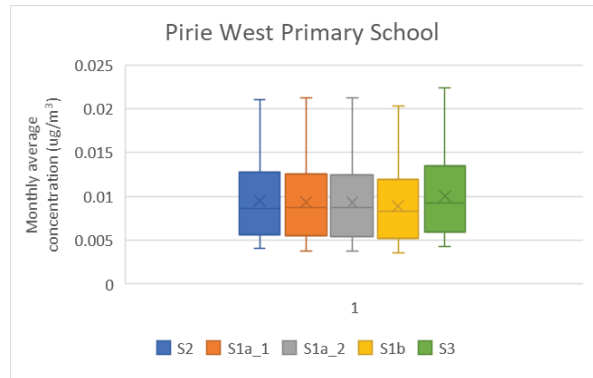

Figure 8 Pirie West Primary School – Cadmium monthly average concentration box plot

PM₁₀

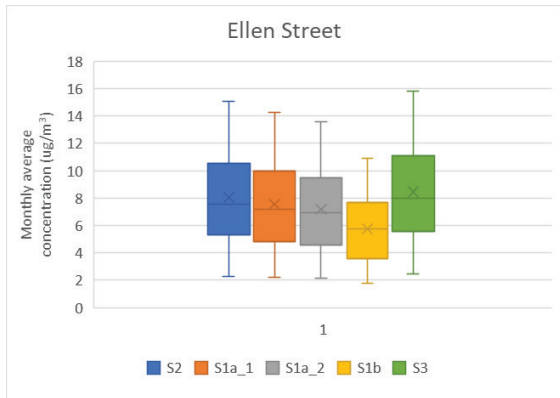

Figure 9 Ellen Street – PM₁₀ monthly average concentration box plot

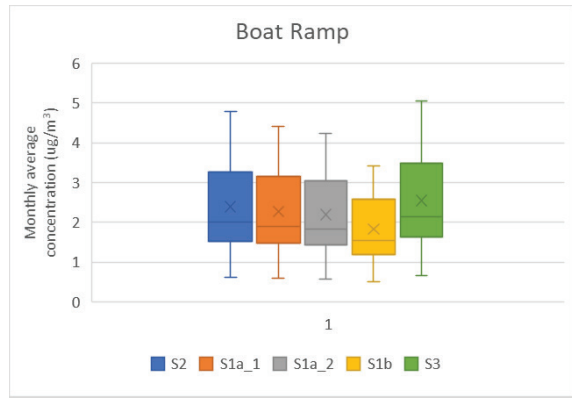

Figure 10 Boat Ramp – PM₁₀ monthly average concentration box plot

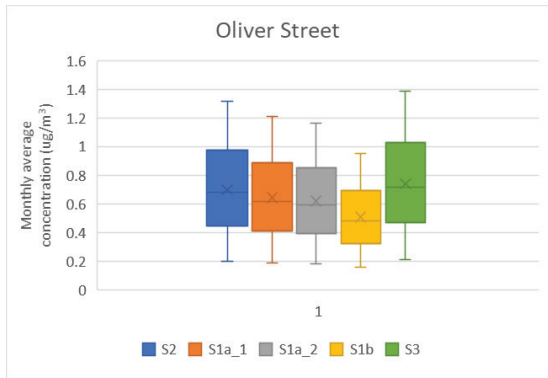

Figure 11 Oliver Street – PM₁₀ monthly average concentration box plot

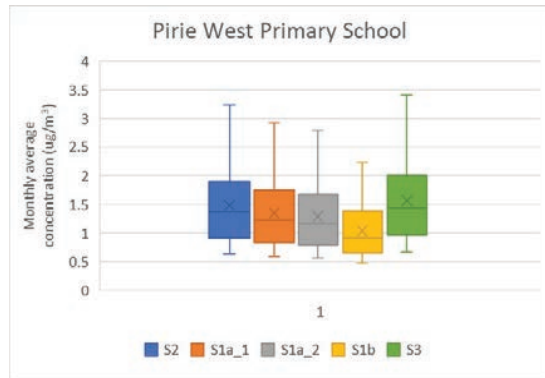

Figure 12 Pirie West Primary School – PM₁₀ monthly average concentration box plot

Lead

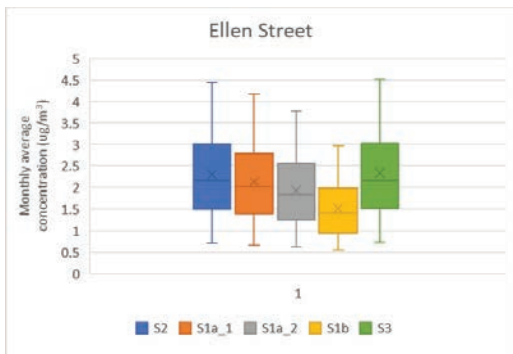

Figure 13 Ellen Street – Lead monthly average concentration box plot

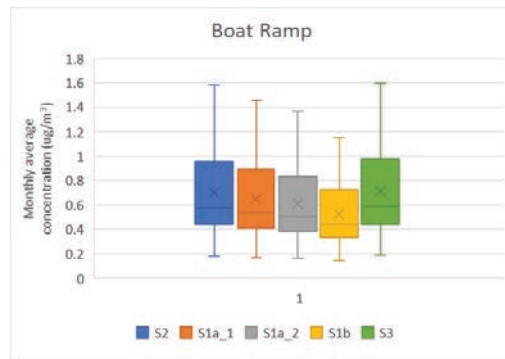

Figure 14 Boat Ramp – Lead monthly average concentration box plot

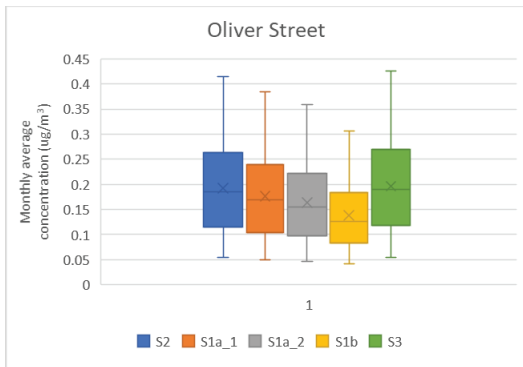

Figure 15 Oliver Street – Lead monthly average concentration box plot

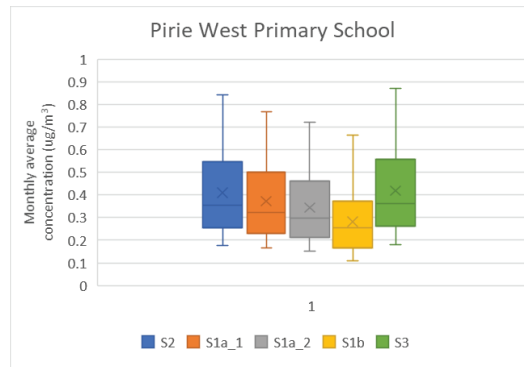

Figure 16 Pirie West Primary School – Lead monthly average concentration box plot

Zinc

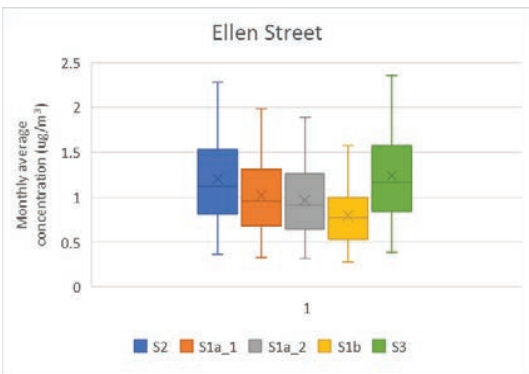

Figure 17 Ellen Street – Zinc monthly average concentration box plot

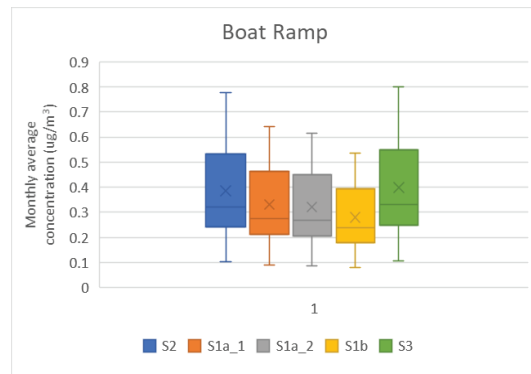

Figure 18 Boat Ramp – Zinc monthly average concentration box plot

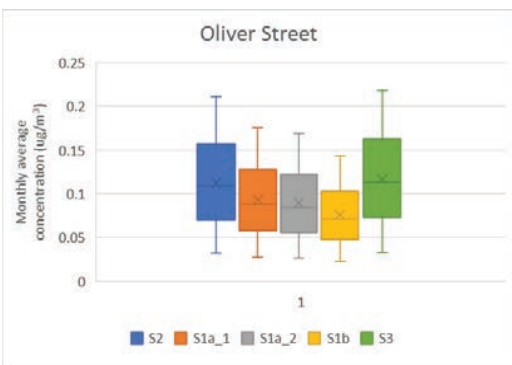

Figure 19 Oliver Street – Zinc monthly average concentration box plot

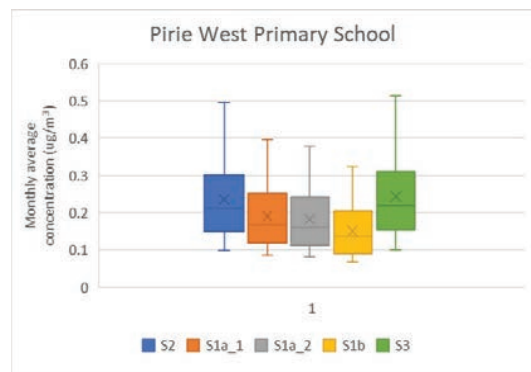

Figure 20 Pirie West Primary School – Zinc monthly average concentration box plot

Conclusion

GHD was engaged by Nyrstar to assess the air quality effects associated with the implementation of a pre-treatment plant at Nyrstar Port Pirie. The need for the assessment arose from recent plans for use of the now redundant sinter plant equipment to create a new process to pre-treat material for use in the blast furnace

To assess the effects of the implementation of the pre-treatment plant, GHD referred to the predicted emission rates for the relevant species (Arsenic, Cadmium, PM₁₀, Lead and Zinc) as well as real time monitoring data for LIA provided by Nyrstar.

Meteorology data generated through CALMET was utilised within CALPUFF to predict the concentrations of each species at four ambient monitoring locations. The CALPUFF results for lead in the base-case scenario (scenario 2) were compared against monitoring data at each location to normalise emission estimates and assess the accuracy of the dispersion model. The results demonstrated that the CALPUFF model slightly overpredicted the monitoring results at locations closer to the site (Ellen Street and Boat Ramp) and underpredicted the monitoring results at locations further from the site (slightly at Oliver Street and greater underprediction at Pirie West Primary School).

Analysis was then undertaken to compare predicted results for each scenario (1a_1, 1a_2, 1b and 3) against the base-case (scenario 2). The general trend revealed that the decreased predicted concentrations for scenario 1a_1 (Pre-treatment with stockpiles - start), scenario 1a_2 (Pre-treatment with stockpiles – 18 months) and scenario 1b (No Pre-treatment with no stockpiles).

The 5% (lead) decrease for scenario 1a_1 and subsequent 10% (lead) decrease for scenario 1a_2 indicates that there is a predicted decrease in concentrations of arsenic, cadmium, PM₁₀, lead and zinc in the atmosphere over the 18 month period after implementation of the Pre-treatment Plant.

The decreased predicted concentrations for scenario 1b, which excludes the Pre-treatment Plant as well as stockpiles, will result in less community pollution in the long term.

Contents

Executive summary	i
1. Introduction	1
1.1 Background	1
1.2 Purpose	1
1.3 Scope and limitations	1
1.4 Assumptions	1
2. Site description	2
2.1 Site layout	2
2.2 Project context	2
2.3 Monitoring locations	2
3. Nyrstar Port Pirie EPA Licence	5
4. Meteorology	6
4.1 Prevailing meteorology	6
4.2 Model set up	7
4.2.1 TAPM	7
4.2.2 CALMET	7
4.3 Meteorological data validation	9
5. Emission inventory	12
5.1 Types of emission sources	12
5.1.1 Stack sources	12
5.1.2 Plant fugitive and boiler sources	13
5.1.3 Stockpile sources	13
5.1.4 Vehicle sources	13
5.2 Operational times	14
5.3 Adopted emission rates	15
6. Dispersion modelling	17
6.1 CALPUFF configuration	17
6.1.1 Model inputs	17
6.1.2 Factored emissions	17
6.2 Base-case - Scenario 2	19
6.2.1 LIA predicted impact	19
6.2.2 EPA licence	23
6.3 Scenario testing	23
6.3.1 Arsenic	24
6.3.2 Cadmium	27
6.3.3 PM ₁₀	30
6.3.4 Lead	33
6.3.5 Zinc	36
7. Conclusion	39

Table index

Table 1	Predicted concentrations 12-month and 3-month averaged	iii
Table 2	Monitoring locations	2
Table 3	EPA licence lead conditions	5
Table 4	Summary of meteorological parameters used in model	6
Table 5	TAPM model parameters	7
Table 6	CALMET parameters	8
Table 7	Observed and predicted Meteorology annual wind roses - 2009	10
Table 8	Stack parameters	12
Table 9	Volume source summary	13
Table 10	Absolute emission rates (g/s)	15
Table 11	Percentage contribution emission rates	16
Table 12	Monthly normalisation factors (based on Dental Clinic)	18
Table 13	Predicted vs monitored LIA concentration	20
Table 14	Predicted and monitored (S2) concentrations 12-month and 3-month averaged	23
Table 15	Predicted absolute and percentage difference - arsenic	25
Table 16	Predicted absolute and percentage difference - cadmium	28
Table 17	Predicted absolute and percentage difference – PM ₁₀	31
Table 18	Predicted absolute and percentage difference - lead	34
Table 19	Predicted absolute and percentage difference - zinc	37

Figure index

Figure 1	Ellen Street - Arsenic monthly average concentration box plot	iv
Figure 2	Boat Ramp - Arsenic monthly average concentration box plot	iv
Figure 3	Oliver Street - Arsenic monthly average concentration box plot	iv
Figure 4	Pirie West Primary School - Arsenic monthly average concentration box plot	iv
Figure 5	Ellen Street – Cadmium monthly average concentration box plot	v
Figure 6	Boat Ramp – Cadmium monthly average concentration box plot	v
Figure 7	Oliver Street – Cadmium monthly average concentration box plot	v
Figure 8	Pirie West Primary School – Cadmium monthly average concentration box plot	v
Figure 9	Ellen Street – PM ₁₀ monthly average concentration box plot	vi
Figure 10	Boat Ramp – PM ₁₀ monthly average concentration box plot	vi
Figure 11	Oliver Street – PM ₁₀ monthly average concentration box plot	vi
Figure 12	Pirie West Primary School – PM ₁₀ monthly average concentration box plot	vi
Figure 13	Ellen Street – Lead monthly average concentration box plot	vii
Figure 14	Boat Ramp – Lead monthly average concentration box plot	vii
Figure 15	Oliver Street – Lead monthly average concentration box plot	vii
Figure 16	Pirie West Primary School – Lead monthly average concentration box plot	vii
Figure 17	Ellen Street – Zinc monthly average concentration box plot	viii
Figure 18	Boat Ramp – Zinc monthly average concentration box plot	viii
Figure 19	Oliver Street – Zinc monthly average concentration box plot	viii
Figure 20	Pirie West Primary School – Zinc monthly average concentration box plot	viii
Figure 21	Major buildings	3
Figure 22	Monitoring locations	4

Figure 23	CALMET land use data (as land use codes with assigned surface roughness values)	9
Figure 24	Average wind speed comparison at Oliver Street - 2009	11
Figure 25	Average wind speed comparison at Boat Ramp - 2009	11
Figure 26	Concentration Q-Q plot for lead at Ellen Street	22
Figure 27	Concentration Q-Q plot for lead at Boat Ramp	22
Figure 28	Concentration Q-Q plot for lead at Oliver Street	22
Figure 29	Concentration Q-Q plot for lead at Pirie West Primary School	22
Figure 30	Ellen Street - Arsenic monthly average concentration box plot	24
Figure 31	Boat Ramp - Arsenic monthly average concentration box plot	24
Figure 32	Oliver Street - Arsenic monthly average concentration box plot	24
Figure 33	Pirie West Primary School - Arsenic monthly average concentration box plot	24
Figure 34	Ellen Street – Cadmium monthly average concentration box plot	27
Figure 35	Boat Ramp – Cadmium monthly average concentration box plot	27
Figure 36	Oliver Street – Cadmium monthly average concentration box plot	27
Figure 37	Pirie West Primary School – Cadmium monthly average concentration box plot	27
Figure 38	Ellen Street – PM ₁₀ monthly average concentration box plot	30
Figure 39	Boat Ramp – PM ₁₀ monthly average concentration box plot	30
Figure 40	Oliver Street – PM ₁₀ monthly average concentration box plot	30
Figure 41	Pirie West Primary School – PM ₁₀ monthly average concentration box plot	30
Figure 42	Ellen Street – Lead monthly average concentration box plot	33
Figure 43	Boat Ramp – Lead monthly average concentration box plot	33
Figure 44	Oliver Street – Lead monthly average concentration box plot	33
Figure 45	Pirie West Primary School – Lead monthly average concentration box plot	33
Figure 46	Ellen Street – Zinc monthly average concentration box plot	36
Figure 47	Boat Ramp – Zinc monthly average concentration box plot	36
Figure 48	Oliver Street – Zinc monthly average concentration box plot	36
Figure 49	Pirie West Primary School – Zinc monthly average concentration box plot	36

Appendices

Appendix A	Scenario 1a_1 emission rates
Appendix B	Scenario 1a_2 emission rates
Appendix C	Scenario 1b emission rates
Appendix D	Scenario 2 emission rates
Appendix E	Scenario 3 emission rates

1. Introduction

1.1 Background

Nyrstar Port Pirie (Nyrstar) is seeking to create a new process to pre-treat material for use in the blast furnace. The new process will use a combination of new equipment and some of the now redundant sinter plant equipment. GHD understands that the proposed pre-treatment process would enable Nyrstar to by-pass the Top Submerged Lance (TSL) furnace and maximise the use of the full Blast Furnace capacity to fast-track removal of the leach product stockpiles on site within a three-to-six-year timeframe.

Part of seeking approval for the new process, Nyrstar requested GHD to assist in assessing air quality impacts in terms of predicted Lead-in-Air (LIA), other metals (such as arsenic) and PM₁₀ from the proposed operation. It is understood that EPA has requested Nyrstar to provide an air quality modelling report prepared in accordance with the EPA publication Ambient Air Quality Assessment (August 2016).

1.2 Purpose

The purpose of this report is to present the results of changes to predicted ground level concentrations of LIA, other metals (such as arsenic) and PM₁₀ through air dispersion modelling. These results will be compared against the limits required by Nyrstar's EPA licence and/or the pollutant ground level concentration (GLC) criteria specified in the Schedule 2 of the Environment Protection (Air Quality) Policy 2016.

1.3 Scope and limitations

This report has been prepared by GHD for Nyrstar Port Pirie and may only be used and relied on by Nyrstar Port Pirie for the purpose agreed between GHD and Nyrstar Port Pirie as set out in section 1.2 of this report.

GHD otherwise disclaims responsibility to any person other than Nyrstar Port Pirie arising in connection with this report. GHD also excludes implied warranties and conditions, to the extent legally permissible.

The services undertaken by GHD in connection with preparing this report were limited to those specifically detailed in the report and are subject to the scope limitations set out in the report.

The opinions, conclusions and any recommendations in this report are based on conditions encountered and information reviewed at the date of preparation of the report. GHD has no responsibility or obligation to update this report to account for events or changes occurring subsequent to the date that the report was prepared.

The opinions, conclusions and any recommendations in this report are based on assumptions made by GHD described in this report (refer section(s) 1.4 of this report). GHD disclaims liability arising from any of the assumptions being incorrect.

1.4 Assumptions

The following assumptions have been made throughout the report:

- All information regarding scenarios and emission rates of the proposed operations to be undertaken at the site provided by Nyrstar is correct and representative
- The local meteorological data measured at Dental Clinic and Boat Ramp, as supplied by Nyrstar for the modelling years 2009 to 2011, is representative of the site and general area
- The local meteorological data measured at the EPA Automatic Weather Station (AWS) at Oliver Street for the modelling years 2009 to 2011 is representative of the urban area of Port Pirie
- Emission rate for “normal operations” has been utilised for scenario modelling

2. Site description

2.1 Site layout

The Port Pirie Lead Smelter is located approximately 850 m north of the Port Pirie town centre. Port Pirie Creek lies to the east of the facility, where ships can travel to load/unload material at the facility docks. Large sections of mangrove lie to the north of the facility, with slag heaps maintained by Nyrstar to the west. Sections of uninhabited land, also owned by Nyrstar, lie to the west (south of the slag heaps). General residential and commercial areas of the Port Pirie township lie to the south. A train line that runs through the town, passing grain silos, and ends (railhead) at the facility next to the docks. The adjacent Port Pirie docks function as a place to receive the concentrates, and final products are dispatched by road and rail.

Within the facility itself, the North and South Baghouses are located north of the tall stack, with the Refinery to the east. The Top Submerged Lance (TSL) furnace is located in the centre of the facility with the Blast Furnace nearby. The Slag Fumer and Kilns Dust Recovery buildings are located at the northern end of the facility. The layout of the facility showing some of the major buildings of relevance to this project can be seen in Figure 21 with ambient monitoring locations indicated in Figure 22.

2.2 Project context

GHD understands that redevelopment of the facility in 2018 included an expansion to be able to process a wider range of high margin feed materials, including zinc smelter residues and concentrates. The sinter plant and sulphuric acid plant were replaced with a state-of-the-art TSL furnace. This expansion was also expected to reduce the amount of airborne metal, dust and sulphur dioxide emissions from the facility into the community.

Nyrstar propose to use some of the now redundant sinter plant equipment to create a new process to pre-treat materials for use in the blast furnace. It is also understood that the proposed pre-treatment process would enable Nyrstar to by-pass the TSL furnace and maximise the use of the full Blast Furnace capacity to fast-track removal of the leach product stockpiles on site within a three-to-six-year timeframe. Thereafter, less fugitive emissions would be generated off the diminishing stockpile areas.

2.3 Monitoring locations

In and around the facility there are four monitoring locations used to quantify the amounts of LIA deposited throughout the site boundary, town and surrounds.

The abbreviation and coordinates of the monitoring locations have been listed below in Table 2. The monitoring locations in the Port Pirie town can be seen in Figure 22 below.

Table 2 Monitoring locations

Abbreviation	Monitoring location	Easting	Northing
ES	Ellen Street	221183.00	6325478.96
BR	Boat Ramp	221991.80	6324501.88
OS	Oliver Street	222185.20	6323142.40
PWPS	Pirie West Primary School	220631.36	6324565.51

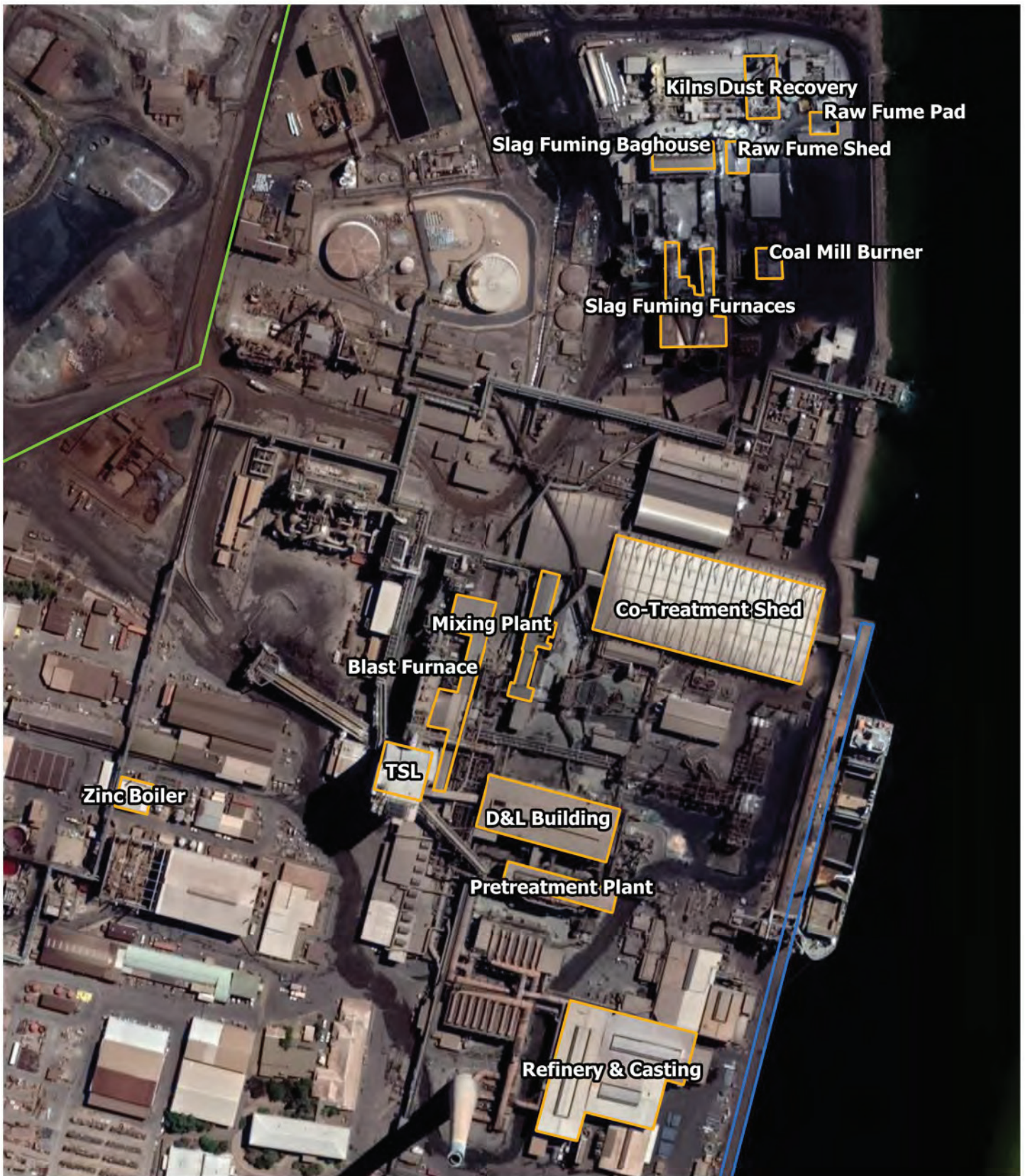

Legend

- Stockpiles
- Ships Unloading
- Plant Building

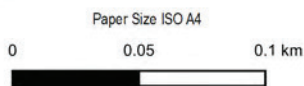

Nyrstar Port Pirie Lead Smelter
 Pretreatment Plant Air Quality Assessment

Project No. 12525626
 Revision No. -
 Date. 21/12/2021

Map Projection: Transverse Mercator
 Horizontal Datum: GDA2020
 Grid: GDA2020 MGA Zone 55

Major buildings

FIGURE 21



Legend

- Boat Ramp
- Oliver Street
- Ellen Street
- Pirie West Primary

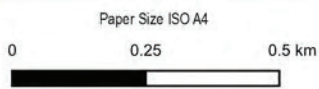

Nystar Port Pirie Lead Smelter
Pretreatment Plant Air Quality Assessment

Project No. **12525626**
 Revision No. **-**
 Date. **30/03/2022**

Monitoring locations

FIGURE 22

3. Nyrstar Port Pirie EPA Licence

A search of the South Australian EPA website revealed that licence 775 was last updated on the 26 August 2021 and issued to Nyrstar. A condition of the licence includes requirements of both targets and limits a limit and target for TSP lead on 12-month averages on a quarterly basis (conditions 1.4 and 1.5) and three-month average targets¹ (condition 1.6) as displayed in Table 3. Where LIA targets are exceeded Nyrstar must provide public notifications and inform the EPA of confirmation of a target being exceeded.

Table 3 EPA licence lead conditions

Averaging period	Location	Exceedance target (µg/m ³)	Exceedance limit (µg/m ³)
Rolling 3 month average	Oliver Street	0.45	
	Pirie West Primary School	0.45	
	Ellen Street	2.2	
	Boat Ramp	1.0	
12 month (calculated bi-annually)	Ellen Street	1.6	
	Boat Ramp	0.6	
12 month (calculated quarterly)	Oliver Street		0.4
	Pirie West Primary School		0.4

¹ "take all reasonable and practicable measures to not exceed"

4. Meteorology

The EPA Ambient Air Quality Assessment (2016) guide states (EPA, 2016, p.11):

- “Dispersion modelling requires the most recent representative meteorological data, best achieved by collection from a site in close proximity to an emission source”.
- “Site-specific data, if available, is preferred.”

4.1 Prevailing meteorology

Local wind climate largely determines the pattern of pollutant dispersion. The characterisation of local wind patterns, as used in dispersion models, requires accurate site-representative hourly recordings of wind direction and speed over a period of at least a year.

Site-representative data from Bureau of Meteorology (BoM) Automatic Weather Station(s) (AWS) are not suitably ‘site-specific’ when compared to the Nyrstar operated ‘Dental Clinic’ and ‘Boat Ramp’ meteorological instrumentation. Data from the latter sources was obtained to characterise the wind field patterns that occur across the site and town due to the building and other surface roughness elements across the Nyrstar site. However, as none of the Nyrstar operated sites measured relative humidity and station pressure, these data were obtained from the EPA monitoring station located on Oliver Street (approximately 3 km south-east of the subject site). The augmentation of another monitoring location of wind in the township area, Oliver Street, was also an advantage of including these extra data.

The data period used was 1 January 2009 to 31 December 2011 inclusive. The first year of the period is recommended by EPA to be the ‘most representative’ year across all the climatic zones of South Australia. However, the winter-time winds in Port Pirie during 2009 were found to have excessive northwest quadrant winds inconsistent with the long-term climate. Hence, a longer (three year) period was used to ensure worst case meteorological conditions are included in the modelling. Raw 10-minute AWS data of wind speed, wind direction, temperature and solar radiation were subjected to QA/QC procedures before conversion to hourly averages. The QA/QC procedures used were consistent with US EPA guidance of Section 8.6 of Meteorological Monitoring Guidance for Regulatory Modelling (sic) Applications (EPA-454/R-99-005). Data validation was performed by a person with appropriate training in meteorology (Applied Meteorologist Barry Cook) who has both an understanding of local meteorological conditions and the operating principles of the instruments. A summary of the meteorological parameters used in this assessment are summarised in Table 4.

Table 4 Summary of meteorological parameters used in model

AWS Location	Height (m)	Parameter used in model
Oliver Street	2	Wind Speed
		Wind Direction
	10	Relative Humidity
		Temperature
Station Pressure		
Dental Clinic	10	Wind Speed
		Wind Direction
Boat Ramp	10	Wind Speed
		Wind Direction

As both Dental Clinic and Boat Ramp recorded data for wind speed and direction and wind measurements at Oliver Street, GHD has utilised prognostic meteorological data generated in The Air Pollution Model (TAPM) to generate a dataset for the years 2009 to 2011 at all three sites. This dataset served as an initial 3D guess field, based on synoptic observations filtered through a Global Circulation Model (GCM) and which utilised local terrain and land use information. This dataset was then included as ‘first-guess’ input into the CALMET meteorological model. A comparison of the prognostic wind data to the observed winds for 2009 to 2011 is discussed in Section 4.3.

4.2 Model set up

4.2.1 TAPM

The TAPM prognostic model was run for the years 2009 to 2011 to obtain a coarse three dimensional meteorological gridded dataset for Port Pirie Pre-treatment plant for the selected model period. In addition, the model was used to provide an initial guess field. This dataset is based on synoptic observations, local terrain and land use information with a resolution of 500 m. The TAPM model parameters are summarised below in Table 5.

Table 5 TAPM model parameters

Parameter	Value
Modelled period	1 January 2009 12:00 am – 31 December 2011 11:59 PM
Domain centre	UTM: 54H 221,210 mE, 6,326,080 mS Latitude = -33°10.5' Longitude= 138°0'
Number of vertical levels	25
Number of Easting grid points	41
Number of Northing grid points	41
Outer grid spacing	20,000 m x 20,000 m
Number of grid levels	5
Grid level horizontal resolution	Level 2- 10,000 m Level 3- 3,500 m Level 4- 1,500 m Level 5- 500 m

4.2.2 CALMET

The CALMET (Version 6.5.0) model was used to resolve the wind field around the site to a 500 m spatial resolution. Upon completion of the broad scale TAPM modelling runs, a CALMET simulation was set up to run for the model period, utilising the three-dimensional gridded data output from TAPM. This approach is consistent with New South Wales Office of Environment & Heritage (OEH) (OEH NSW, 2011) guidance documentation. All model settings were selected based on the NSW OEH guidance and as per the CALPUFF modelling guidelines. CALMET was run using the “Hybrid” mode with the TAPM data provided as an initial guess field. The southwest corner of the CALMET domain, or the origin, was located at UTM Zone 54 coordinates 213.172 km east and 6315.580 km north. The CALMET model was run for a 16 km by 17 km domain with a 0.5 km grid resolution.

The CALMET model parameter RMAX is used when excluding certain grid points from being influenced by meteorological observations. It is often used in complex terrain situations where ridges and valleys would result in grid points located near each other being subject to different wind conditions. Setting an RMAX value of 15 km for example, means that any grid point located greater than 15 km from the meteorological observations would not be influenced by meteorological observations, and would instead be 100 percent influenced by the prognostic data (step 1 wind field).

For this assessment, a large RMAX value of 500 km has been used. This means that any grid point located greater than 500 km from the meteorological observations would not be influenced by the meteorological observations at Oliver Street, Boat Ramp or Dental Clinic, and would instead be 100 percent influenced by the TAPM prognostic data. GHD has used a large RMAX value (500 km extends well beyond the end of the meteorological grid) as there are no points within the grid that are required to be excluded from being influenced by three weather station observations.

The CALMET model parameter R1 is the distance weighting of the meteorological observations on the grid points surrounding the observations. At the location of the meteorological observations, the grid points are influenced 100 percent by the meteorological observations and 0 percent by the prognostic data (step 1 wind field). This then decreases with distance by a rate of $(1/R^2)$. The R1 value represents the distance from a surface observation station at which the surface observation and the Step 1 wind field are weighted equally. For this assessment, a R1 value of 10 km was selected, which means that:

- At the Nyrstar Port Pirie location, the grid point is influenced by 100 percent observations and 0 percent TAPM
- At 10 km from the Nyrstar Port Pirie location, the grid point is influenced by 50 percent observations and 50 percent TAPM
- At 20 km from the Nyrstar Port Pirie location, the grid point is influenced by 0 percent observations and 100 percent TAPM

GHD selected a R1 value of 10 km based on the spatial spread of the three wind observation sites, arial measurement of the Nyrstar Port Pirie location to the end of town and the lack of significant terrain within the Port Pirie area. The wind conditions experience at the Nyrstar Port Pirie location is expected to be similar to observed weather conditions as interpolated for the nearby measurement sites.

The CALMET model parameters were set to the values presented in Table 6 below. Land use and 3D terrain data was used for the CALMET modelling with land use displayed in Figure 23.

Table 6 CALMET parameters

Parameter	Specification
Modelled period	1 January 2009 – 31 December 2011
Mode	Hybrid (Noobs = 1), surface data (surf.dat) incorporated
Domain origin (SW Corner)	213.172 km east 6315.580 km north
Domain size	16 km x 17 km
Number or vertical levels	12
Vertical levels (m)	0 m, 20 m, 40 m, 80 m, 120 m, 240 m, 480 m, 1000 m, 2000 m, 3000 m, 4000 m, 5000 m
CALMET setting for Hybrid mode	TERRAD = 15 RMAX1 = 500 km RMAX2 = 500 km RMIN = 0.1 km R1 = 10 km R2 = 500 km
Surface data	Oliver Street: wind speed and wind direction at 10 m, temperature, relative humidity and station pressure at 2 m Boat Ramp: wind speed and wind direction at 10 m Dental Clinic: wind speed and wind direction at 10 m
Upper air data	No site-specific upper air data was used (up.dat)
Land use and terrain data	Land use data was sourced from Lakes CALPUFF View and edited to more accurately reflect the land use in the area. Terrain data was sourced from Lakes CALPUFF View.

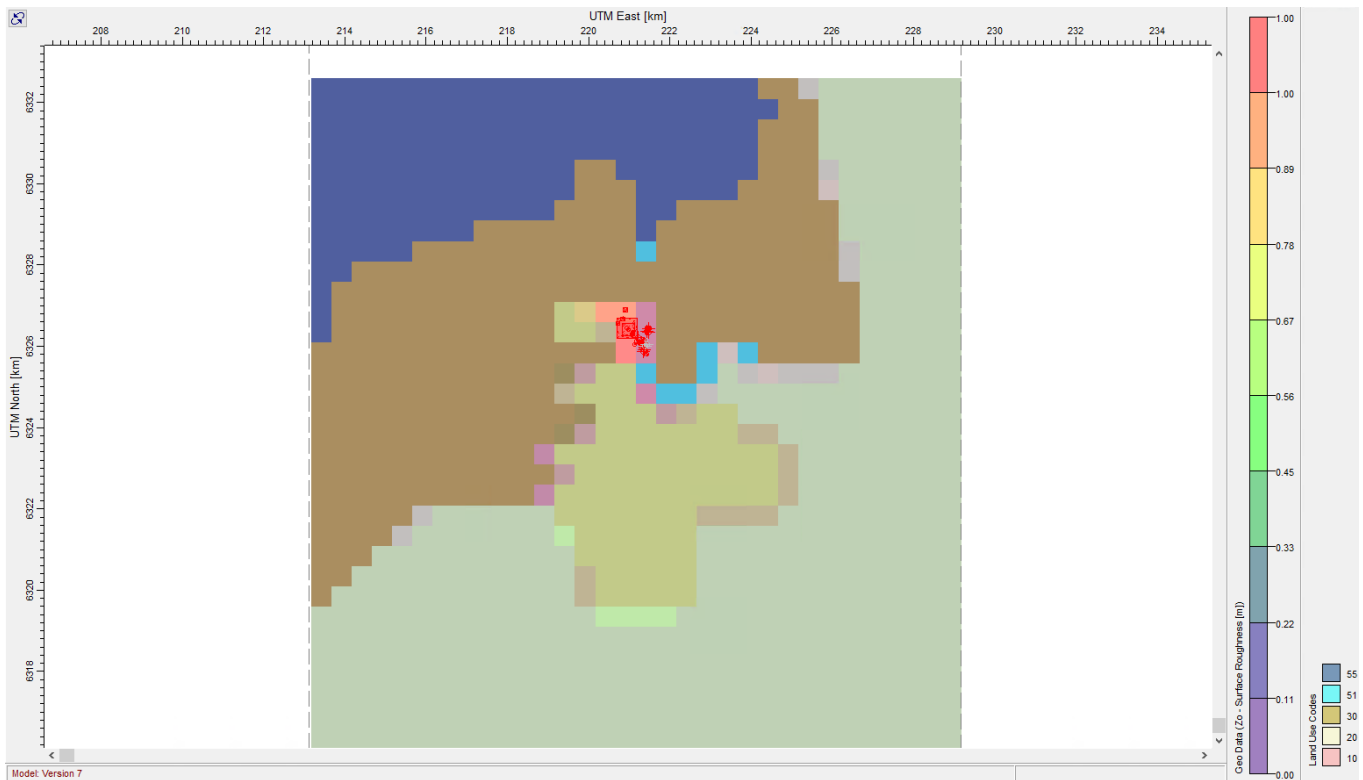

Figure 23 CALMET land use data (as land use codes with assigned surface roughness values)

4.3 Meteorological data validation

Oliver Street was considered to be most representative of meteorology within the residential zone of the Port Pirie town. Boat Ramp was considered for its coastal location to examine winds from across the open stretch of water to the south and east of the Nyrstar processing site. Wind roses generated by TAPM for 2009 at Oliver Street and Boat Ramp within the assessment period are provided in column 3 of Table 7. Conclusions from the analysis of wind roses derived from TAPM include:

- TAPM simulated winds slightly underpredict observed wind speeds at both locations
- TAPM simulated winds fails to capture higher speed winds (>6 m/s) from the north-northwest directions

Considering the slight underprediction of wind speeds, the use of TAPM data as input to CALMET is assessed as being suitable for location meteorology at Nyrstar Port Pirie site. Winds are corrected by the Hybrid mode in CALMET and wind roses generated by CALMET are provided in column 4 of Table 7 and compared to onsite observations provided by EPA SA and Nyrstar. Comparison of all average wind speeds are shown in Figure 24 and Figure 25. After the CALMET Hybrid mode corrections to the first-guess windfield have been made, the following conclusions can be drawn:

- CALMET simulated winds capture wind speeds well at Oliver Street with a slight underprediction at Boat Ramp
- CALMET simulated winds captures wind directions well at both locations

Table 7 Observed and predicted Meteorology annual wind roses - 2009

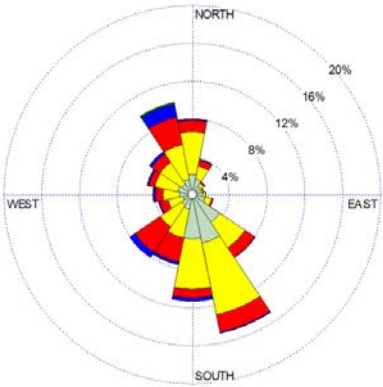
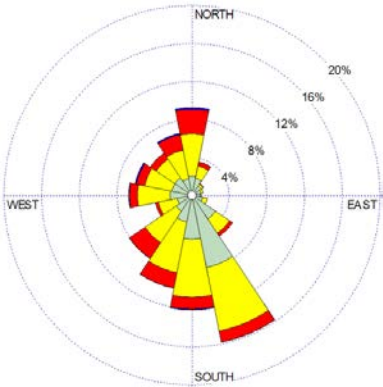
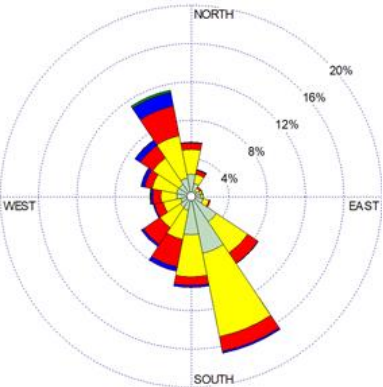
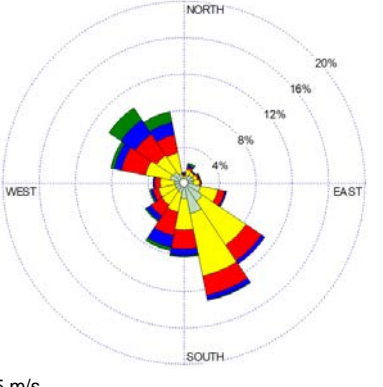
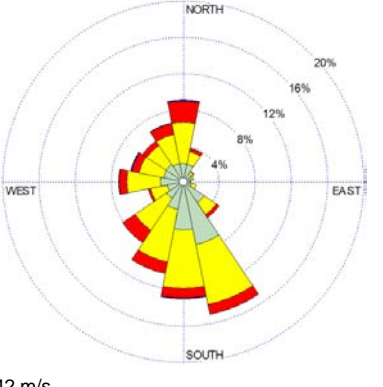
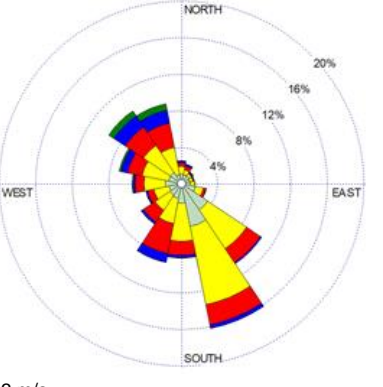
Month	AWS Data	TAPM	CALMET
Oliver Street	 <p>2.77 m/s</p>	 <p>2.5 m/s</p>	 <p>2.78 m/s</p>
Boat Ramp	 <p>3.5 m/s</p>	 <p>2.42 m/s</p>	 <p>3.13 m/s</p>

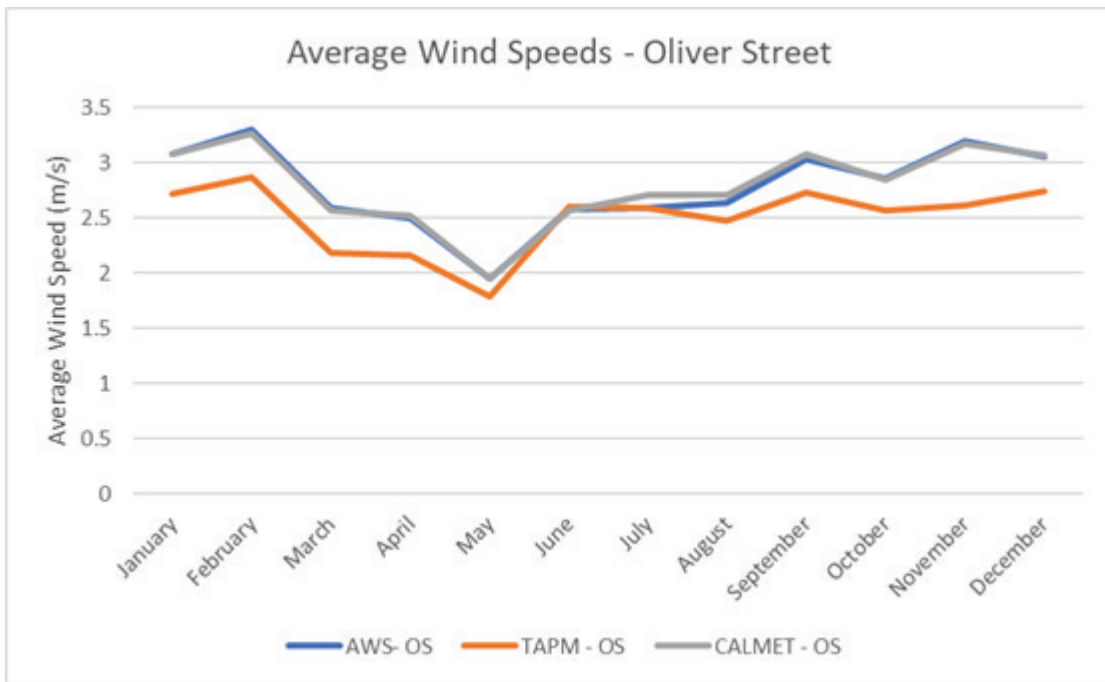

Figure 24 Average wind speed comparison at Oliver Street - 2009

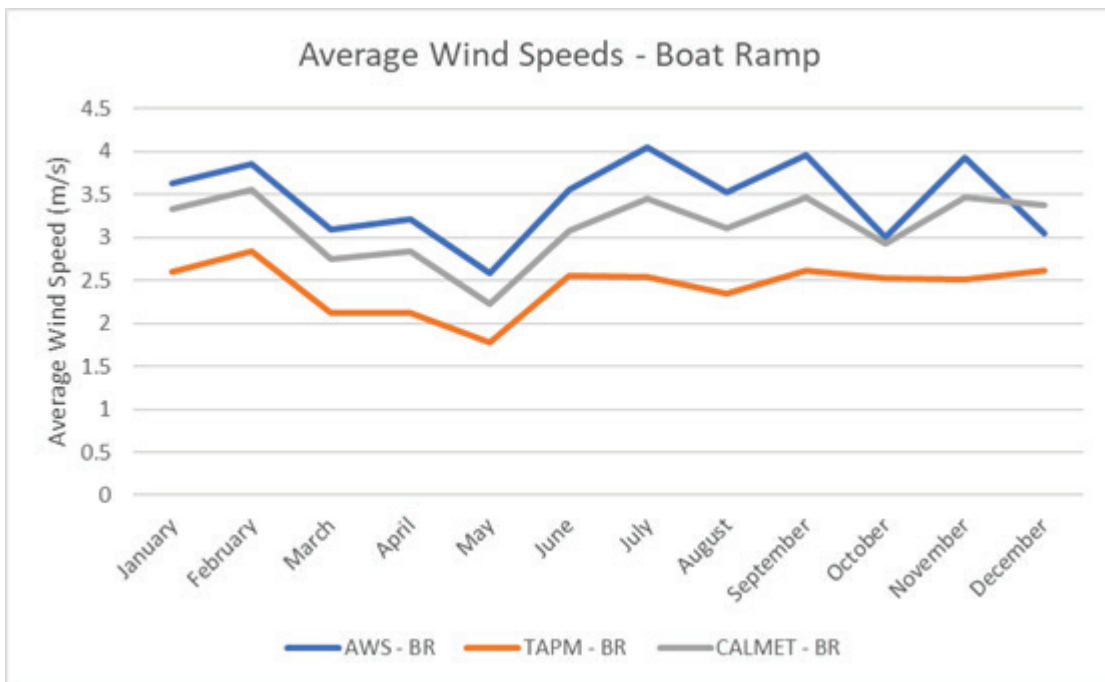

Figure 25 Average wind speed comparison at Boat Ramp - 2009

5. Emission inventory

GHD utilised emission data provided by Nyrstar to undertake dispersion modelling for sources located within the facility. Emission estimates were provided for the pollutants:

- PM₁₀
- Lead
- Arsenic
- Cadmium
- Zinc

5.1 Types of emission sources

The various types of emissions from onsite processes that result in offsite impact can be categorised as follows:

- Stack sources
- Plant fugitive sources
- Stockpile sources
- Vehicle sources

Initial emission data for the above sources was obtained from measurements and estimation techniques conducted at the facility by Nyrstar in 2021.

5.1.1 Stack sources

Nine stack sources were modelled by GHD.

Details of stack parameters used in the emissions model were obtained from information provided by Nyrstar and from previous projects at the facility. These include stack height, diameter, exit temperature and exit velocity. The composition of stack emissions calculated in the NPI reporting was obtained through onsite testing conducted throughout the year by Assured Environmental. Emission details are summarised below in Table 8.

All stack sources were modelled as point sources in the CALPUFF model.

Table 8 Stack parameters

Stack	Stack diameter (m)	Velocity (m/s)	Temperature (K)	Stack height (m)
Blast Furnace Enclosure Baghouse	1.5	13.4	306	21.5
5 m Smelter Baghouse Flue	5	16.1	343	205
Pre-treatment Plant Number 6 Scrubber	0.9	12	329	22.7
Combined Scrubber Pre-treatment Plant	0.9	8.4	316	24.4
3 m Refinery Flue	3	14.2	387	205
Acid Plant	2.2	10.3	302	60
Slag Fuming Main Baghouse	1.85	29.9	399	44.2
Kilns Dust Recovery Combined	0.9	10.8	331	36.5
SF Coal Mill Baghouse	1.0	1.0	318	23.0

5.1.2 Plant fugitive and boiler sources

Thirty-four fugitive emission sources and one boiler emission sources were modelled by GHD.

Plant fugitive emissions were categorised into two separate emission sources in the NPI reporting spreadsheet, namely Field Investigations and Handbook Estimations. Fugitive emissions and boiler emission sources were modelled as volume sources, with the relative dimensions of each building taken into account.

5.1.3 Stockpile sources

Six stockpile emission sources and three loading/unloading emission sources were modelled by GHD.

Emission rates from the various stockpiles onsite were separated into those areas defined in the NPI data. The stockpiles located in and around the PIT area were defined as volume sources with the dimensions based on information provided by Nyrstar. A generalised initial height of 1.0 m was assumed for all stockpiles located in the PIT area. The unloading of material from trains and ships modelled were located next to the train stop and on the docks, respectively.

Wind erosion from stockpiles located outdoors are heavily influenced by the local meteorological conditions and, as such, all stockpile emission rates were calculated based on the meteorological data obtained throughout the year.

5.1.4 Vehicle sources

Lead emissions from vehicle operation at the facility occur only due to wheel generated dust, with the composition of the emissions based on assay data from the PIT area (provided by Nyrstar). These emissions are a function of Vehicle Kilometres Travelled (VKT). Wheel generated dust was modelled as a volume source and was located over a large section of the PIT area in order to encompass all emissions.

Table 9 Volume source summary

Building description	Source ID	Source Description	Height
Volume source - boilers			
	1	Zinc Leach Plant - Presha Boiler	17.6
Volume sources - plant fugitives (field investigations)			
TSL Area Fugitive Emissions - Total	2.1	TSL Furnace	40.25
	2.2	TSL Slag Caster vents	
	2.3	TSL Slag Caster Discharge Chute	
Blast Furnace Fugitive Emissions - Total	3.1	Blast Furnace Secondary Enclosure	17.6
	3.2	Blast Furnace - Granulator	
	3.3	Blast Furnace Tapping Floor	
	3.4	Blast Furnace Crane Aisle	
	3.5	Copper Drossing Furnace (CDF) Recirculating Launder	
	3.6	Copper Drossing Furnace (CDF) Charge Chute	
	3.7	Blast Furnace Holding Pans and launders	
	3.8	Bullion ladles	
Refinery Plant Fugitive Emissions - Total	4.1	Liquation Kettles	10
	4.2	Final Refining Pans	
	4.3	B7/B8 de-zincing	

Building description	Source ID	Source Description	Height
Slag Fumer Plant Fugitive Emissions - Total	5.1	Slag Fumer Tapping Floor	15.4
	5.2	Slag Fumer Gas Train	
	5.3	Recuperators	
	5.4	Brick Flue	
	5.5	Balloon Flue	
	5.6	Slag Fuming Baghouse fugitives	
	5.7	SF BH Screws	
	5.8	Raw Fume Pad	
Pre-treatment Plant Fugitive Emissions - Total	6.1	IMP Hopper	23
	6.2	IMP Feed Hopper	
	6.3	Tip End	
Kilns Plant Fugitive Emissions - Total	7.1	Kilns Discharge End	9.8
	7.2	Kilns Dust Recovery Plant (KDR)	
	7.3	KDR - Wind-blown dust	
	8	Raw Fume Shed	5
Volume sources - plant fugitives (handbook estimations)			
	9	Lead Refinery	9.8
	10	Casting - Lead	3
	11	Mixing Plant (EM refers to as "Charge Building")	17.6
	12	Pretreatment Plant - Main Machine	23
	13	Copper Drossing Furnace	11
	14	TSL Furnace Tapping Platform	40.25
Volume sources - plant fugitives (handbook estimations)			
	15	PIT/Crusher area	1
	16	Uncovered PGP stockpile	1
	17	Uncovered LSLC stockpile	1
	18	Uncovered BuLP stockpile	1
	19	TSL slag blocks & residue mixes stockpiles	1
	20	Black sand stockpile	1
	21	Ships unloading	10
	22	Trains unloading	4
	23	Trucks loading	4
Volume sources - vehicle emissions			
	24	Wheel generated emissions	3

5.2 Operational times

GHD notes that emissions from each source do not occur at all hours of the year, however modelling has been undertaken with all hours as a worst-case scenario. The time-varying nature of the emissions, especially stack sources, were normalised utilising a multiple-regression approach that scaled fixed monthly emission rates to measured ambient levels (see discussion in section 6.1.2).

5.3 Adopted emission rates

A summary of adopted emission rates for each source is provided in Appendix A to Appendix E which shows all relevant sources with their relative emission rates and totals for each scenario. Details of emission have been taken from data provided by Nyrstar, as follows:

- Stack emissions have been based upon tests conducted onsite by Assured Environmental (AE) and provided in the NPI reporting data. These emissions represent the averages of the resulting data, along with operational efficiencies of the various plants. Where no operational times have been given, the plant efficiencies have been assumed to be 100%, (i.e. operating all hours of the year).
- Plant fugitive emissions were based upon the operational efficiencies of each plant and the data provided in the draft 2019 NPI report. Where percent time was included for emissions from field investigations in the NPI report, emissions were averaged across the operational times of the respective plants.

The five pollutants (arsenic, cadmium, lead, PM₁₀ and zinc) were assessed each through a total of five scenarios, as follows:

- Scenario 1a_1: Pre-treatment with stockpiles (Start)
- Scenario 1a_2: Pre-treatment with stockpiles (18 months)
- Scenario 1b: No pre-treatment and no stockpiles (including Product Recycling Facility)
- Scenario 2: No pre-treatment with stockpiles (Current operations)
- Scenario 3: Pre-treatment trial

Scenario 2 was taken as the base-case scenario as it remains the most representative of current operations undertaken at Nyrstar Port Pirie. A comparison of the remaining scenarios against these base-case emissions is discussed in Section 6.2.2.

Table 10 and Table 11 show the absolute emission rates and percentage contribution emission rates respectively applied for each scenario. In comparison to the base-case scenario, both scenarios 1a and four have similar higher emission rates, while scenario 1b generally has a lower emission rate.

Table 10 Absolute emission rates (g/s)

		S1a_1	S1a_2	S1b	S2	S3
Arsenic	Point	0.057	0.057	0.056	0.056	0.057
	Fugitive	0.077	0.077	0.080	0.078	0.082
	Stockpile	0.008	0.008	0.000	0.017	0.018
	Total	0.142	0.142	0.136	0.151	0.157
Cadmium	Point	0.068	0.068	0.064	0.064	0.068
	Fugitive	0.101	0.101	0.102	0.102	0.104
	Stockpile	0.003	0.003	0.000	0.008	0.009
	Total	0.172	0.172	0.166	0.174	0.181
Lead	Point	0.773	0.773	0.757	0.757	0.773
	Fugitive	3.036	3.021	3.164	3.165	3.267
	Stockpile	1.108	0.823	0.008	1.437	1.444
	Total	4.916	4.617	3.929	5.359	5.484
PM ₁₀	Point	3.358	3.358	3.259	3.259	3.358
	Fugitive	7.706	7.687	7.559	7.308	8.047
	Stockpile	7.338	6.743	3.956	9.673	9.823
	Total	18.402	17.788	14.773	20.241	21.228
Zinc	Point	0.450	0.450	0.447	0.446	0.450
	Fugitive	1.553	1.549	1.579	1.551	1.603
	Stockpile	0.697	0.608	0.206	1.305	1.354
	Total	2.701	2.607	2.231	3.303	3.407

Table 11 *Percentage contribution emission rates*

		S1a_1	S1a_2	S1b	S2	S3
Arsenic	Point	40%	40%	42%	37%	36%
	Fugitive	54%	54%	58%	51%	52%
	Stockpile	6%	6%	0%	11%	11%
Cadmium	Point	40%	40%	39%	37%	38%
	Fugitive	59%	59%	61%	59%	58%
	Stockpile	2%	2%	0%	5%	5%
Lead	Point	16%	17%	19%	14%	14%
	Fugitive	62%	65%	81%	59%	60%
	Stockpile	23%	18%	0%	27%	26%
PM ₁₀	Point	18%	19%	22%	16%	16%
	Fugitive	42%	43%	51%	36%	38%
	Stockpile	40%	38%	27%	48%	46%
Zinc	Point	17%	17%	20%	14%	13%
	Fugitive	58%	59%	71%	47%	47%
	Stockpile	26%	23%	9%	40%	40%

6. Dispersion modelling

Dispersion modelling was conducted to predict the maximum ground level concentrations resulting from emissions from the premises. Various emission scenarios were developed to meet the objectives of the modelling assessment.

Dispersion modelling was undertaken using CALPUFF.

6.1 CALPUFF configuration

6.1.1 Model inputs

The model parameters and inputs were:

- Meteorological configurations for TAPM and CALMET as described in Section 4
- CALPUFF v7
- The receptor grid was taken to match the meteorological grid at 16 km x 17 km
- Modelling period was taken from 2009 to 2011
- Monthly factored emissions as discussed in section 6.1.2 have been applied

6.1.2 Factored emissions

A worst-case scenario has been assumed for all pollutants and modelled for all hours of the years 2009 to 2011. GHD has applied a monthly normalisation factor to best represent real-time observed emissions being dispersed to result in observed measured impacts. The derived normalisation factors were applied to point sources, fugitive sources and stockpile sources based on the assumed (conservative as modelled) emission rates and measured real-time LIA data provided by Nyrstar.

A normalisation factor is applied to reduce model errors where some months are:

- Underpredicted (two months) due to inherent limitations in the emission inventory and variable dispersion due to meteorology
- Overpredicted (34 months) due to the conservative nature of the emission inventory where plant, operations and other sources are always on. The combination of emissions factors being high and the dispersion meteorology for that month produces modelled data which are higher than reality (as measured).

The monthly normalisation factors are provided in Table 12, where month one represents January 2009 and month 36 represents December 2011. Table 12 shows that some months are (raw) predicted very well, for example month 11 (where the normalisation fraction is within a few percent) while other months are significantly overpredicted (for example month five where the emissions are reduced to one third to predict the measured data).

Table 12 *Monthly normalisation factors (based on Dental Clinic)*

Month	Point	Fugitive	Stockpile
1	0.891	0.871	0.881
2	0.817	0.797	0.807
3	0.377	0.357	0.367
4	0.495	0.475	0.485
5	0.333	0.313	0.323
6	0.369	0.349	0.359
7	0.298	0.278	0.288
8	0.330	0.310	0.320
9	0.705	0.685	0.695
10	0.647	0.627	0.637
11	1.006	0.986	0.996
12	1.356	1.336	1.346
13	0.947	0.927	0.937
14	1.194	1.174	1.184
15	0.809	0.789	0.799
16	0.526	0.506	0.516
17	0.331	0.311	0.321
18	0.272	0.252	0.262
19	0.164	0.144	0.154
20	0.277	0.257	0.267
21	0.259	0.239	0.249
22	0.481	0.461	0.471
23	0.610	0.590	0.600
24	0.519	0.499	0.509
25	0.660	0.640	0.650
26	0.397	0.377	0.387
27	0.262	0.242	0.252
28	0.478	0.458	0.468
29	0.333	0.313	0.323
30	0.396	0.376	0.386
31	0.913	0.893	0.903
32	0.396	0.376	0.386
33	0.790	0.770	0.780
34	0.546	0.526	0.536
35	0.815	0.795	0.805
36	0.636	0.616	0.626

6.2 Base-case - Scenario 2

6.2.1 LIA predicted impact

Monitored data for LIA was provided at Ellen Street, Boat Ramp and Oliver Street. Together with the Pirie West Primary School site, these four monitoring locations, while located close to the facility sources, essentially representative of the facility's impact on ambient concentrations. The Ellen Street represents boundary conditions, and therefore would be expected to have the highest predicted (and measured) concentrations while Boat Ramp, Oliver Street and Pirie West Primary School are representative of community exposure. Table 13 below shows a comparison of monitored and predicted (i.e. modelled) total monthly concentrations of lead at the various monitoring locations over 2009 to 2011.

Q-Q plots were used to compare the monthly results at each monitoring location after the application of the monthly factored emissions for the base-case scenario (the closest representation to plant operations at the time of the measurements). Figure 26 to Figure 29 show the monthly concentration Q-Q plots for the four monitoring locations discussed in Section 2.3.

The general pattern of the modelled results sees the model slightly over predicting the total concentration at locations closer to the site (Ellen Street and Boat Ramp), while underprediction occurs at locations further from the site (slightly for Oliver Street and Pirie West Primary School). The Pirie West Primary School has the greatest underprediction as it is downwind (see Table 7) of the site operational sources the least of the four sites. Winds east of north are required to bring site emissions to the Primary school while the other three sites are impacted by site emissions when winds are west of north. As the Primary School is an outlier to the other three sites, the predictions are less accurate for this site and suggests that a source other than the operational sources is contributing. The unknown background source could be legacy lead from many years of smelter operations or other unidentified contributors.

The under or over prediction does not impact greatly the methodology of comparing scenarios at each site. While the absolute amount of LIA at each site will change between scenarios, the difference expressed as a percentage change from the base-case is independent of the degree of over or under prediction.

GHD notes that the Ellen Street monitor has missing data for the first three months of 2009.

Table 13 Predicted vs monitored LIA concentration



GHD results (Modelled)

LIA Data (measured)

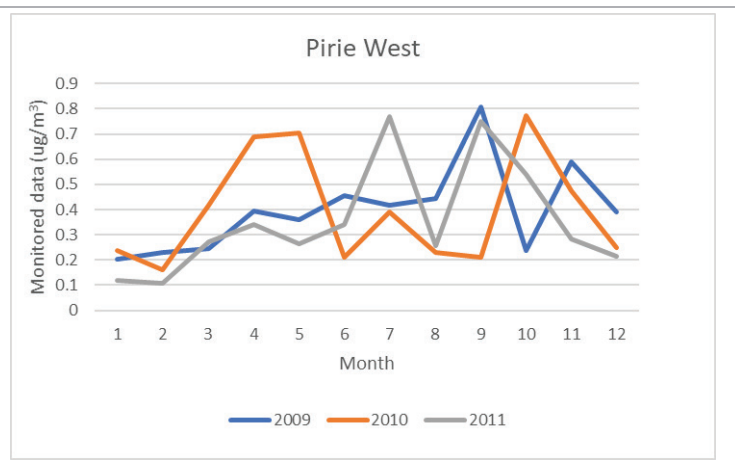
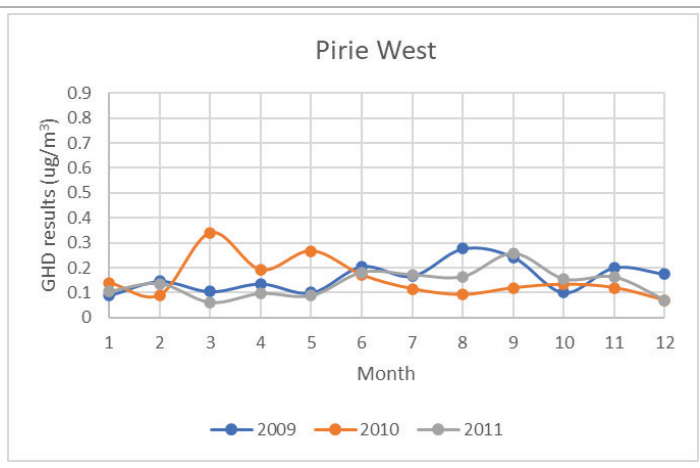
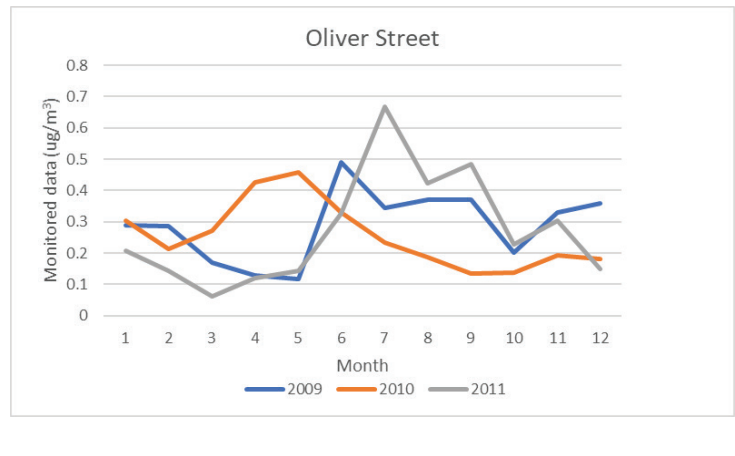
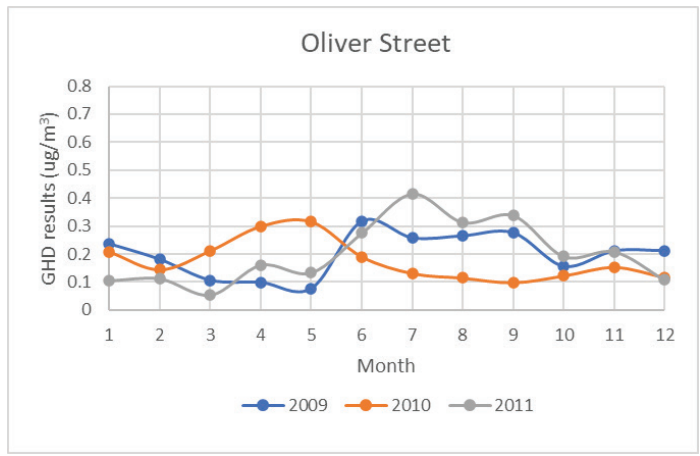

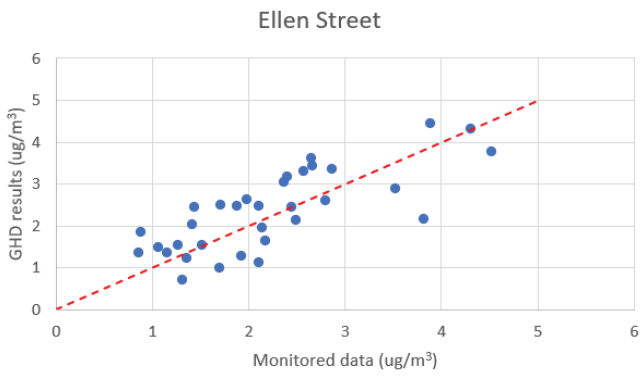

Figure 26 Concentration Q-Q plot for lead at Ellen Street

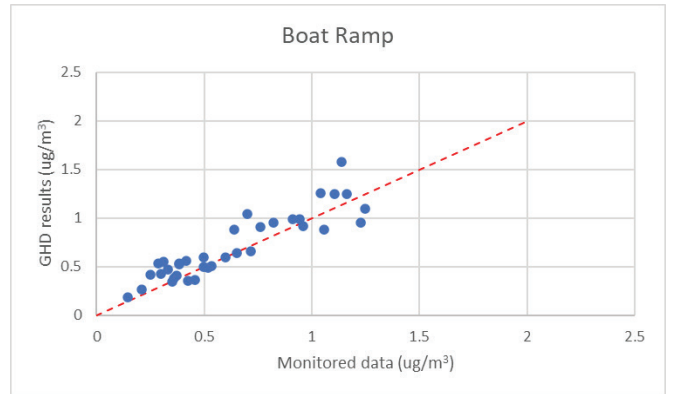

Figure 27 Concentration Q-Q plot for lead at Boat Ramp

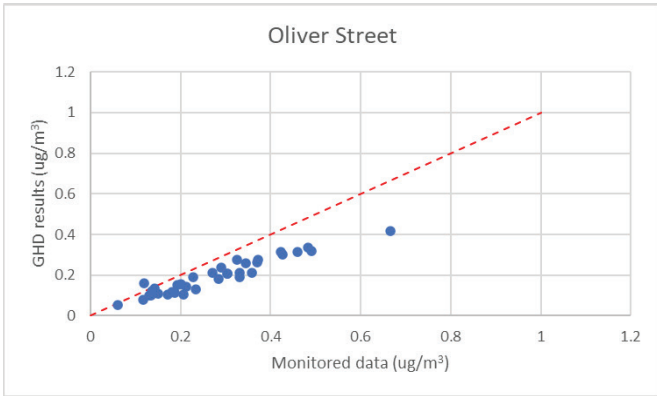

Figure 28 Concentration Q-Q plot for lead at Oliver Street

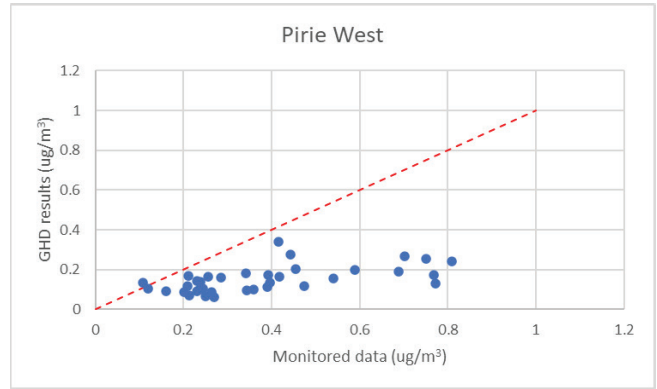

Figure 29 Concentration Q-Q plot for lead at Pirie West Primary School

6.2.2 EPA licence

As discussed in Section 3, EPA has specified limit and target exceedance criteria for LIA at several locations near Nyrstar Port Pirie. The predicted LIA concentration for the scenarios modelled over the 2009 to 2011 modelled period is compared against the exceedance criteria in Table 14. The limits and targets are based on measured ambient concentrations rather than predicted values. All locations and averaging periods are modelled to be within the licence criteria. A conclusion is made that the base-case modelling is a fair reflection of the plant impact on the surrounding community locations. It then follows that Scenario 1 (a and b) have lower predicted impacts at the licence locations.

The average concentrations for S3 in Table 14 were calculated from monitoring data up to 30 September 2021. The predicted scenarios (S1 variations and S2) show the changes in average concentrations as modelled, based on the changes of each scenario inventory from the Pre-Treatment Trial scenario (S3).

Table 14 Predicted and monitored (S2) concentrations 12-month and 3-month averaged (Monitoring data at 30 September 2021)

Averaging period	Location	Licence criteria ($\mu\text{g}/\text{m}^3$)	Predicted concentrations ($\mu\text{g}/\text{m}^3$)				
			S1a_1	S1a_2	S1b	S2	S3
Rolling 3 month average	Oliver Street	0.45	0.39	0.36	0.30	0.42	0.42
	Pirie West Primary School	0.45	0.34	0.31	0.26	0.37	0.38
	Ellen Street	2.2	1.99	1.81	1.45	2.11	2.17
	Boat Ramp	1.0	0.72	0.66	0.60	0.78	0.78
12 month (calculated half-yearly)	Ellen Street	1.6	1.40	1.31	1.08	1.53	1.53
	Boat Ramp	0.6	0.50	0.46	0.42	0.54	0.54
12 month (calculated quarterly)	Oliver Street	0.4	0.25	0.23	0.20	0.27	0.27
	Pirie West Primary School	0.4	0.28	0.26	0.22	0.31	0.31

6.3 Scenario testing

Following analysis of the base-case scenario as discussed in Section 6.2, the predicted concentrations of the remaining scenarios have been compared against the base-case scenario 2. Figure 30 to Figure 49 displays the average monthly concentration box plot for the four monitoring sites (Ellen Street, Boat Ramp, Oliver Street and Pirie West Primary School). Table 15 to Table 19 display the results for each species at these four monitoring sites, where each graph represents the difference between predicted concentrations of scenario 2 and the remaining scenarios. The graphs have been presented with both the absolute values as well as percentage differences.

Of the predicted concentrations in comparison to the base-case scenario, the general trend shows:

- A decrease in predicted concentrations for scenario 1a_1, 1a_2 and 1b subsequently, for PM₁₀, Lead and Zinc at all monitoring sites.
- Similar predicted concentrations for scenario 1a_1, 1a_2 and 1b, for Arsenic and Cadmium at all monitoring sites.
- An increase in predicted concentration for scenario 3 for all species at all monitoring sites.

The small decreasing trend predicted concentrations from the base-case scenario to 1a_1 indicates that implementation of the Pre-treatment Plant operations may result in slightly decrease concentrations of arsenic, cadmium, PM₁₀, lead and zinc in the atmosphere. The further slight decrease from scenario 1a_1 to 1a_2 indicates that after 18 months there will be a predicted further decrease in monthly concentrations for all species in the atmosphere.

The decreased predicted concentrations for scenario 1b in the longer term excludes the emissions from the Pre-treatment Plant as well as stockpiles.

6.3.1 Arsenic

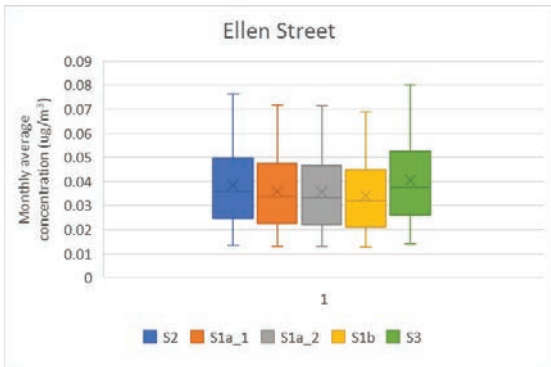

Figure 30 Ellen Street - Arsenic monthly average concentration box plot

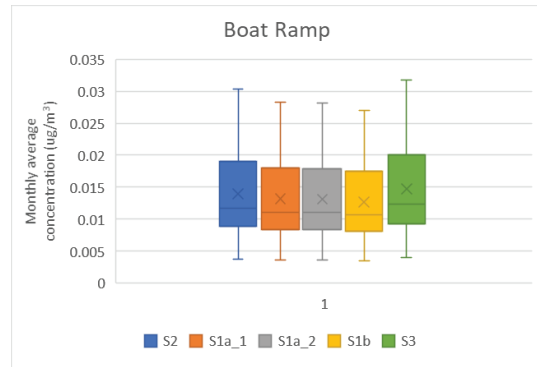

Figure 31 Boat Ramp - Arsenic monthly average concentration box plot

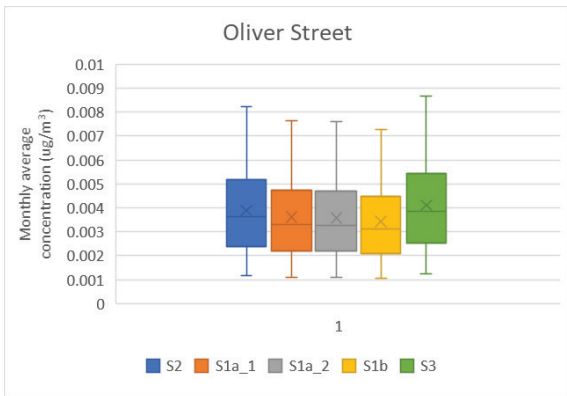

Figure 32 Oliver Street - Arsenic monthly average concentration box plot

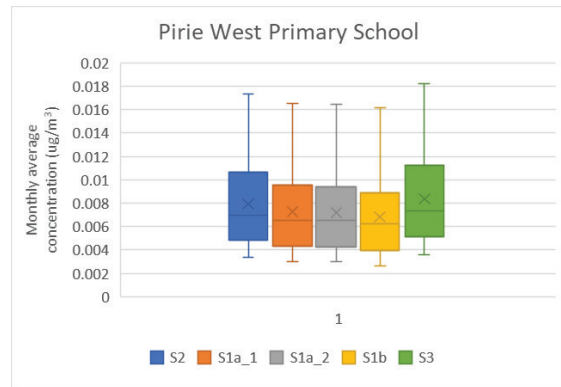
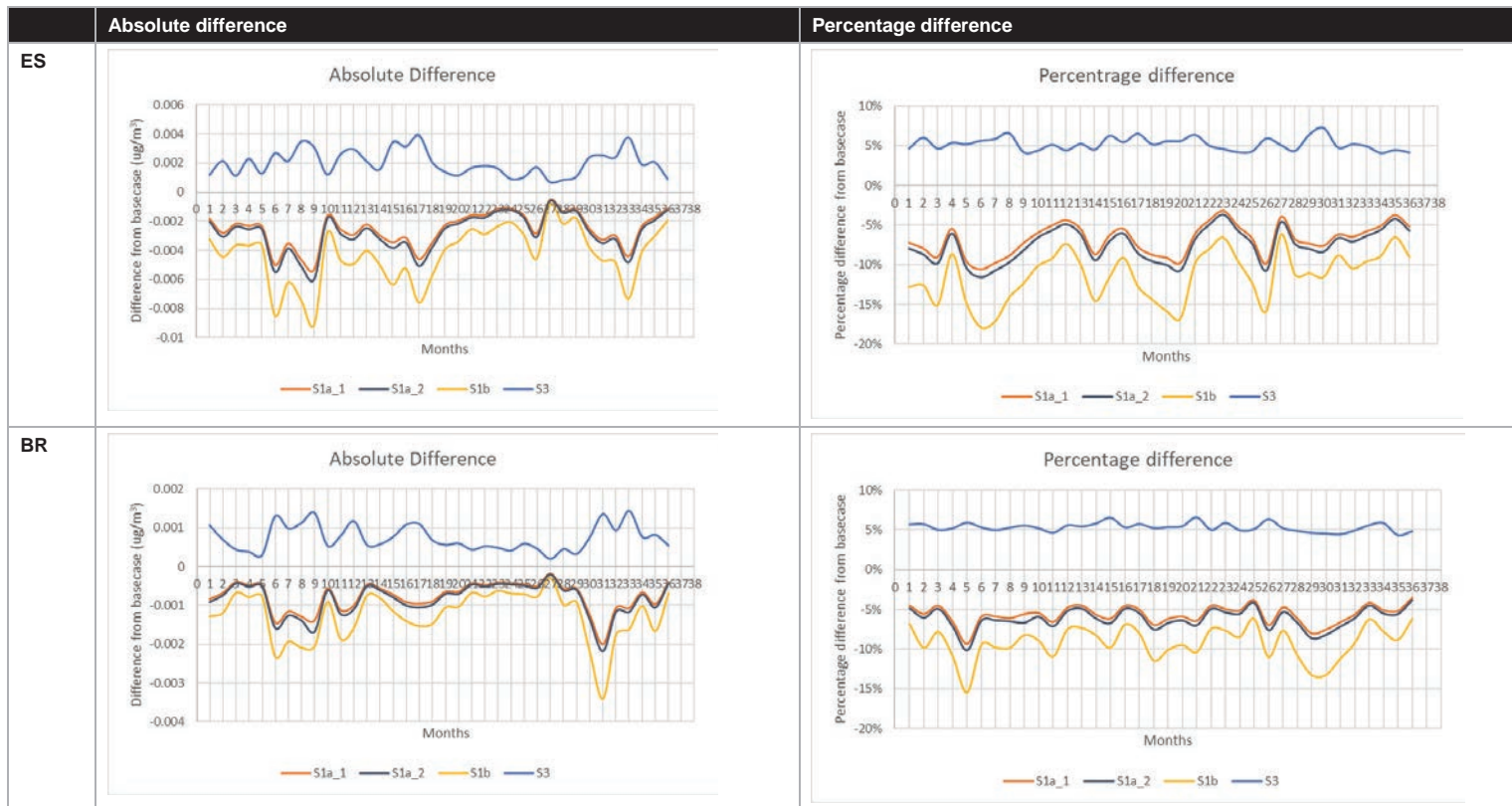
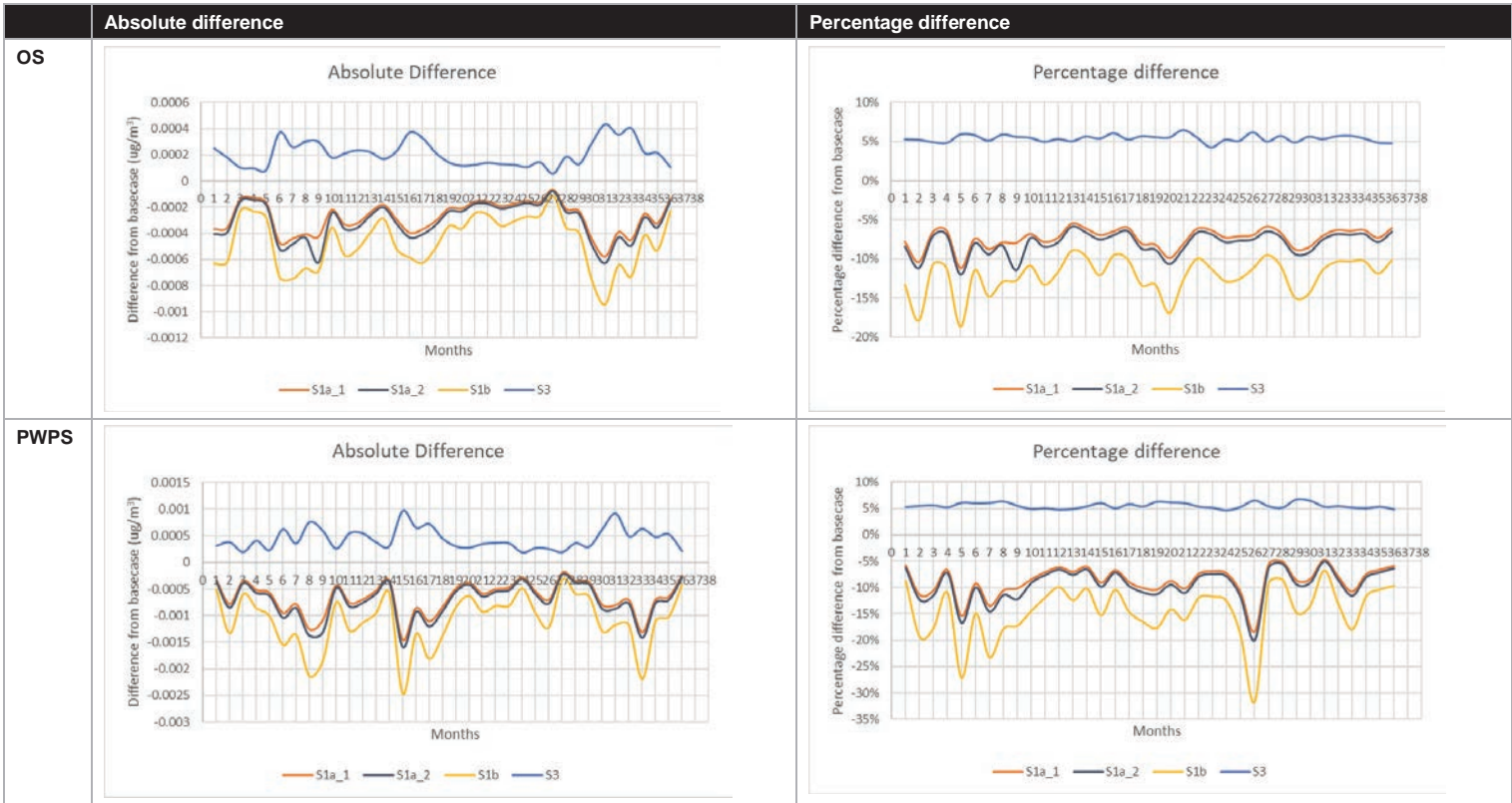

Figure 33 Pirie West Primary School - Arsenic monthly average concentration box plot

Table 15 Predicted absolute and percentage difference - arsenic





6.3.2 Cadmium

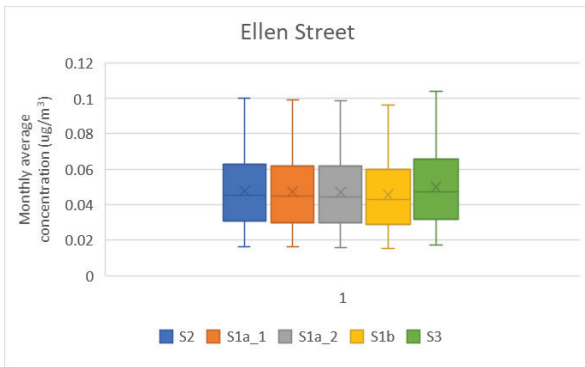

Figure 34 Ellen Street – Cadmium monthly average concentration box plot

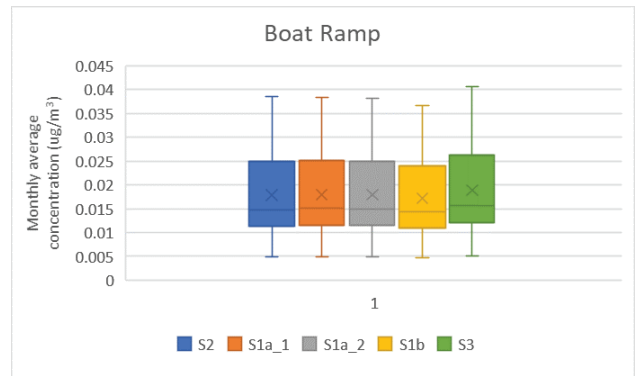

Figure 35 Boat Ramp – Cadmium monthly average concentration box plot



Figure 36 Oliver Street – Cadmium monthly average concentration box plot

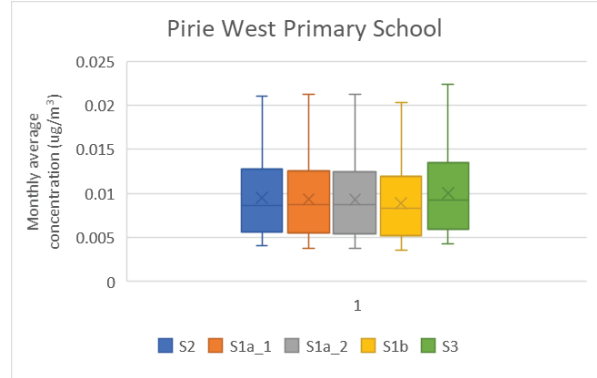
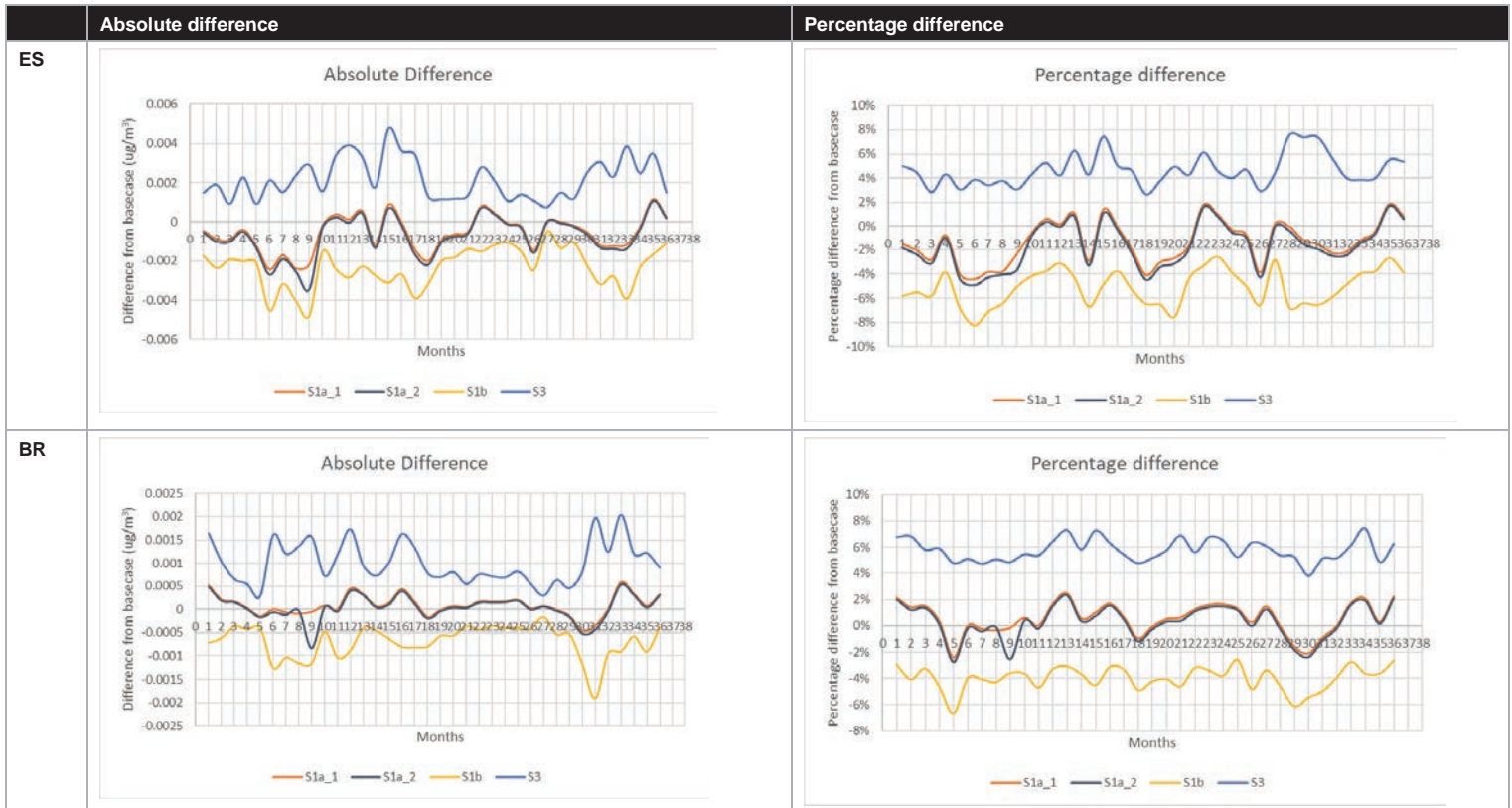
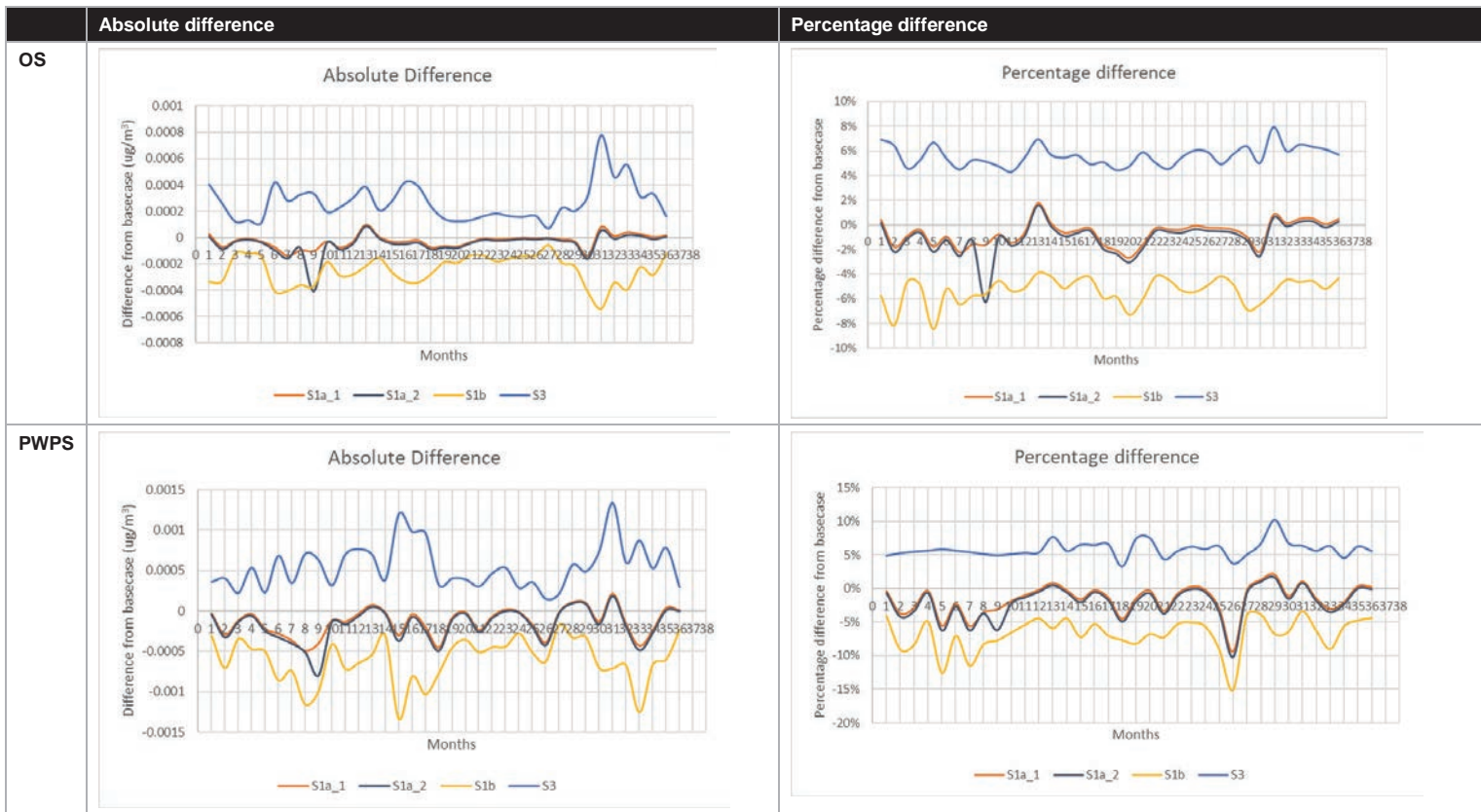

Figure 37 Pirie West Primary School – Cadmium monthly average concentration box plot

Table 16 Predicted absolute and percentage difference - cadmium





6.3.3 PM₁₀

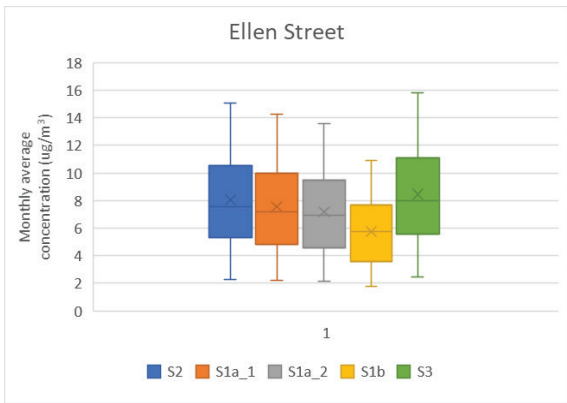

Figure 38 Ellen Street – PM₁₀ monthly average concentration box plot

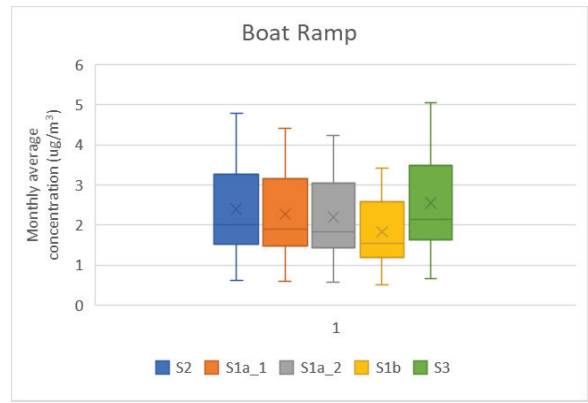

Figure 39 Boat Ramp – PM₁₀ monthly average concentration box plot

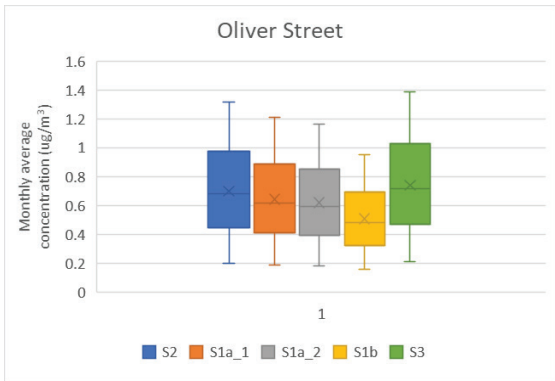

Figure 40 Oliver Street – PM₁₀ monthly average concentration box plot

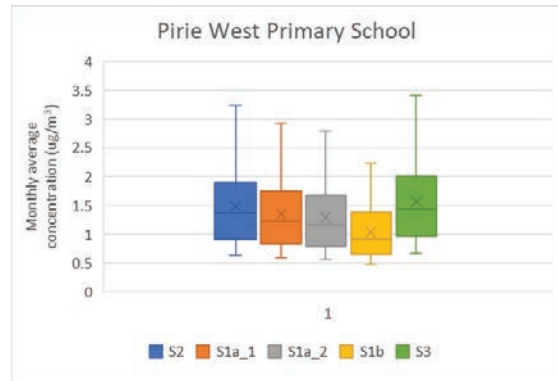
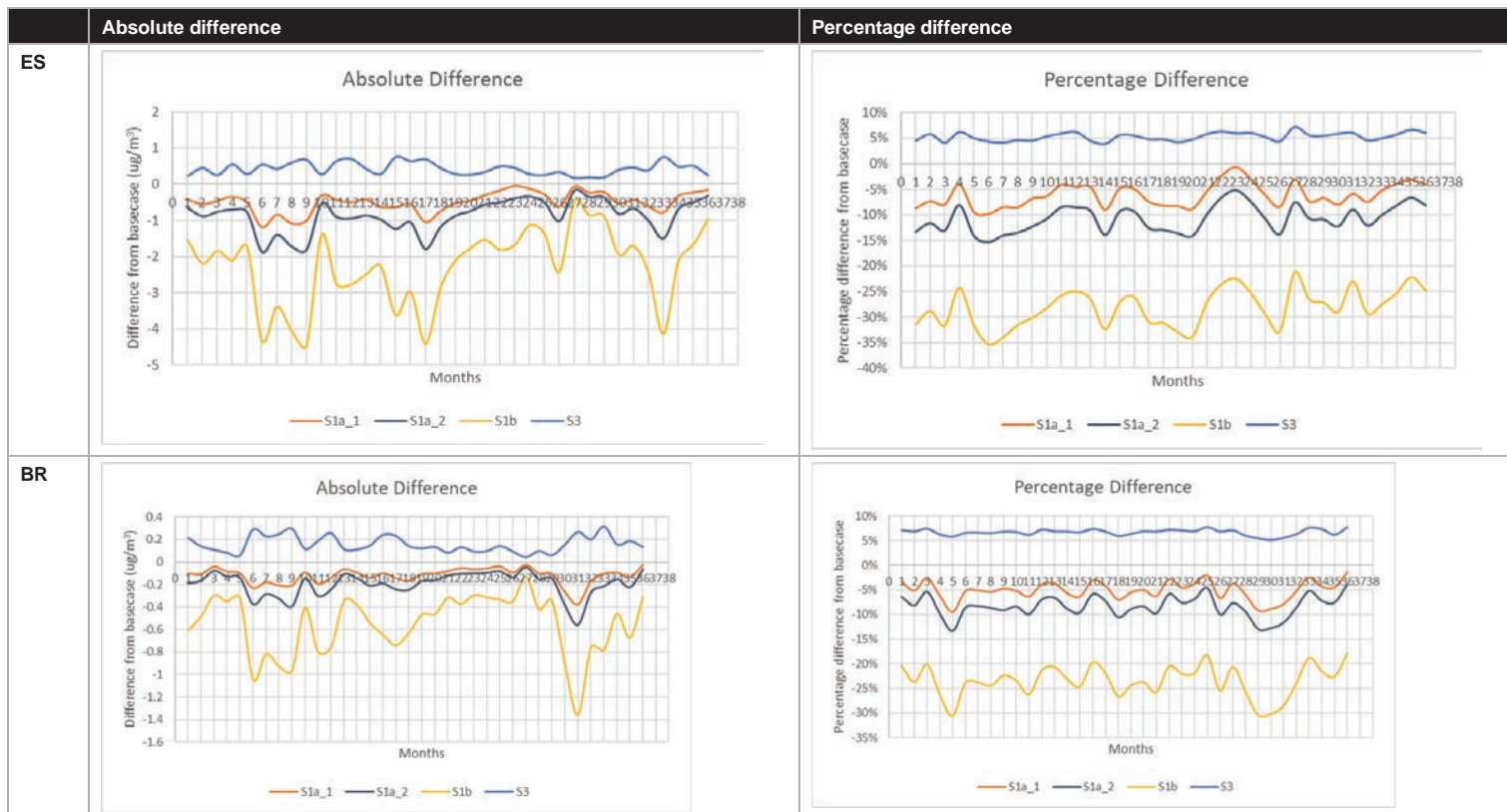
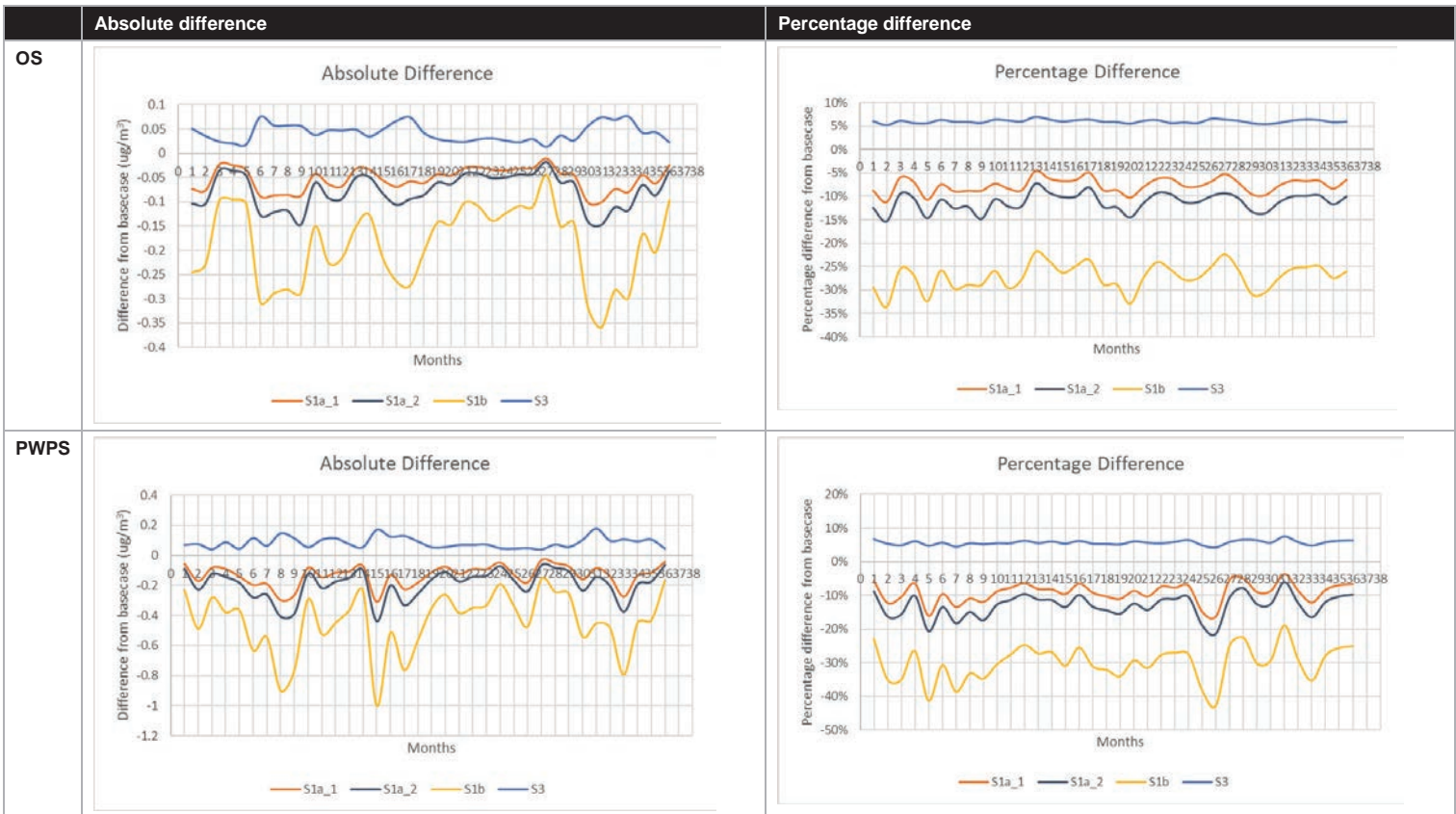

Figure 41 Pirie West Primary School – PM₁₀ monthly average concentration box plot

Table 17 Predicted absolute and percentage difference – PM₁₀





6.3.4 Lead

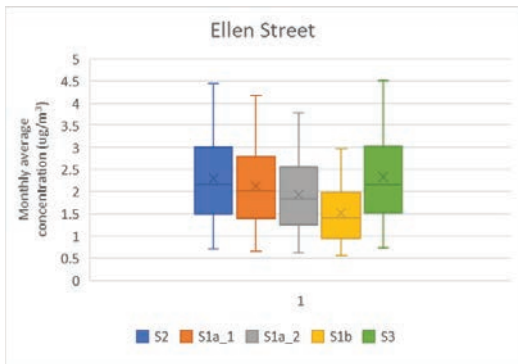

Figure 42 Ellen Street – Lead monthly average concentration box plot

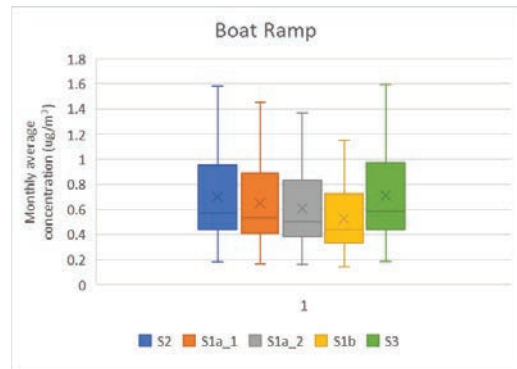

Figure 43 Boat Ramp – Lead monthly average concentration box plot

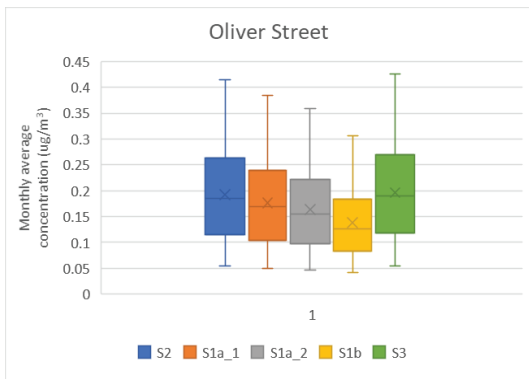

Figure 44 Oliver Street – Lead monthly average concentration box plot

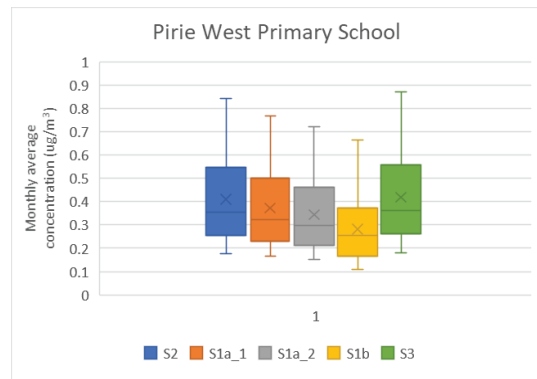
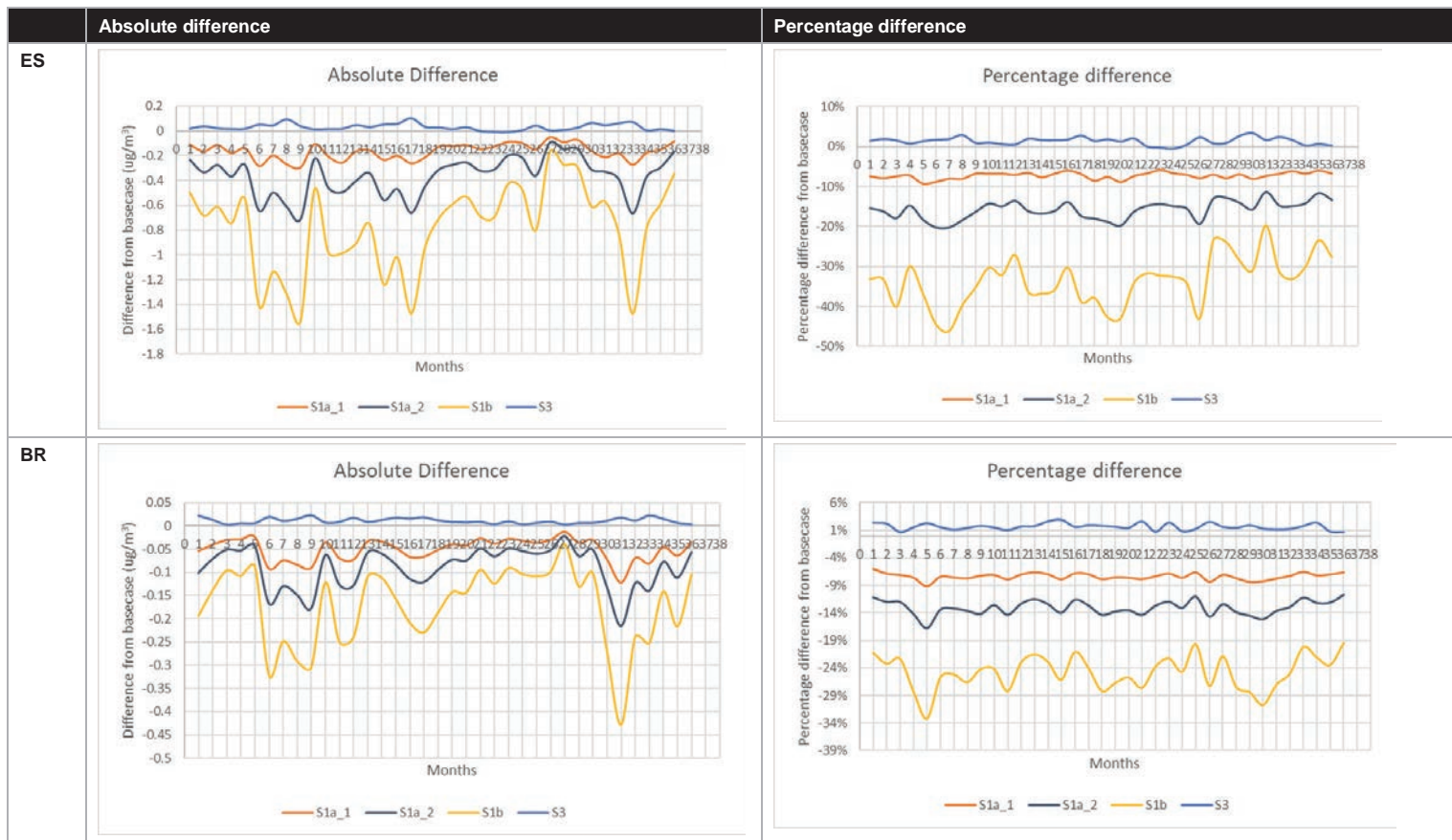
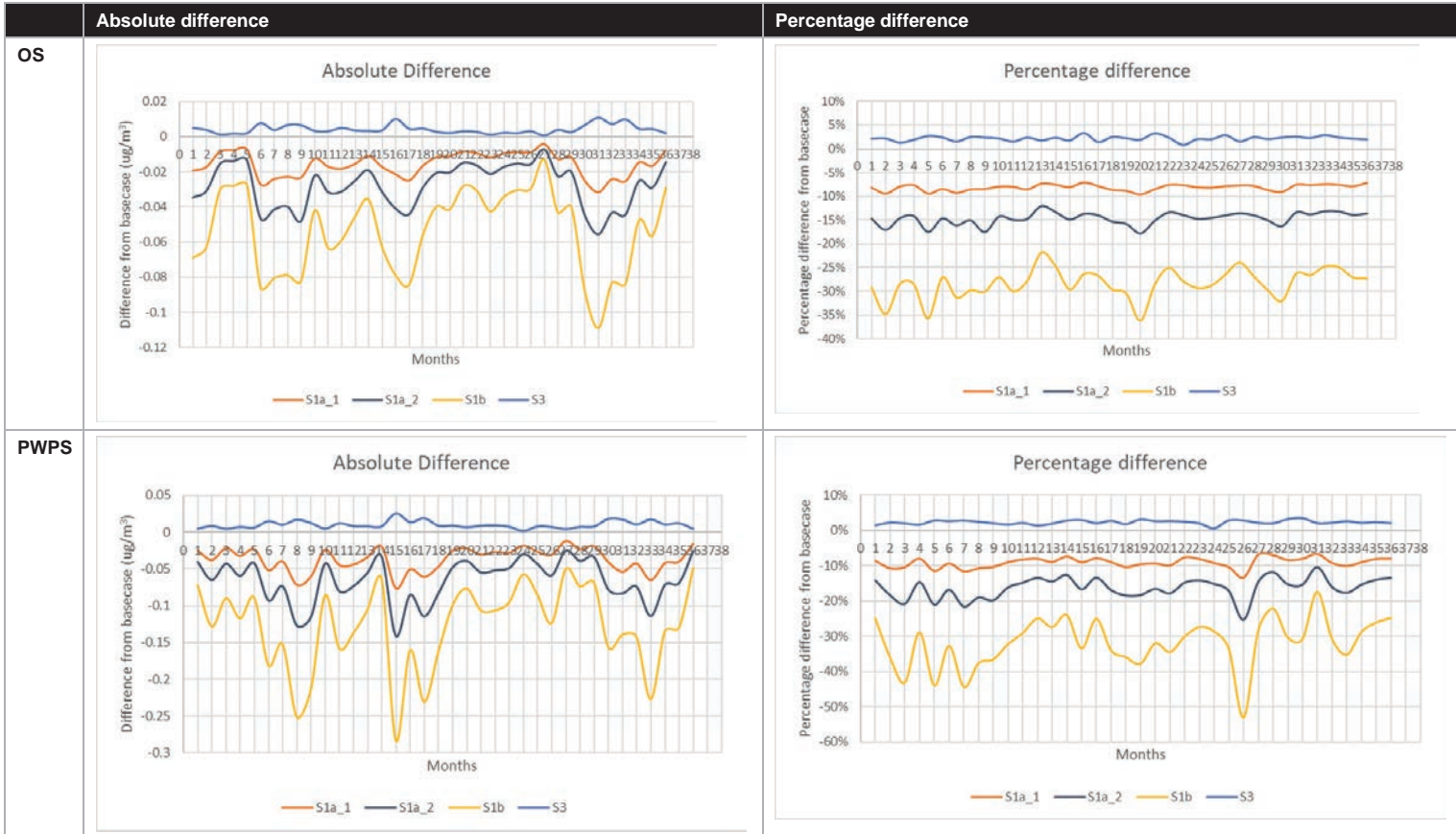

Figure 45 Pirie West Primary School – Lead monthly average concentration box plot

Table 18 Predicted absolute and percentage difference - lead





6.3.5 Zinc

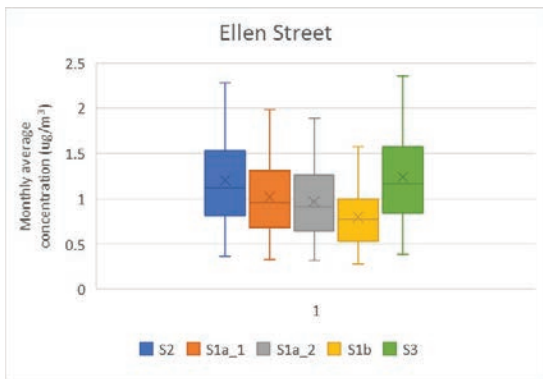

Figure 46 Ellen Street – Zinc monthly average concentration box plot

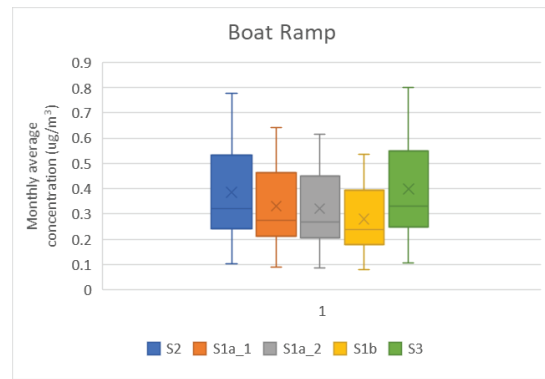

Figure 47 Boat Ramp – Zinc monthly average concentration box plot

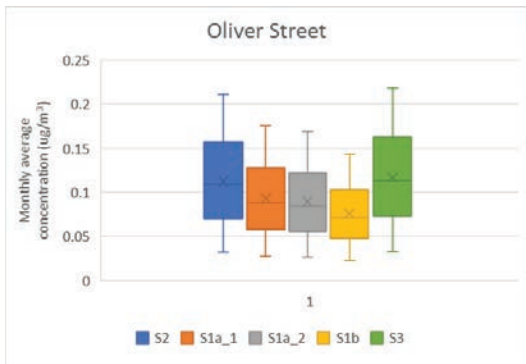

Figure 48 Oliver Street – Zinc monthly average concentration box plot

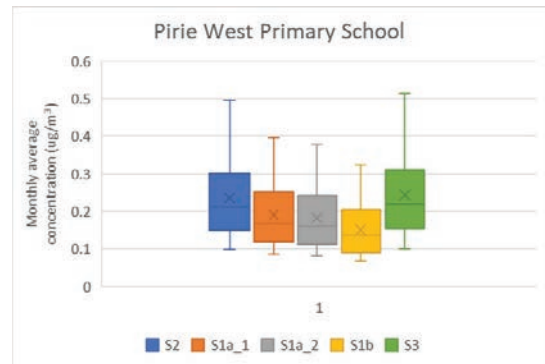
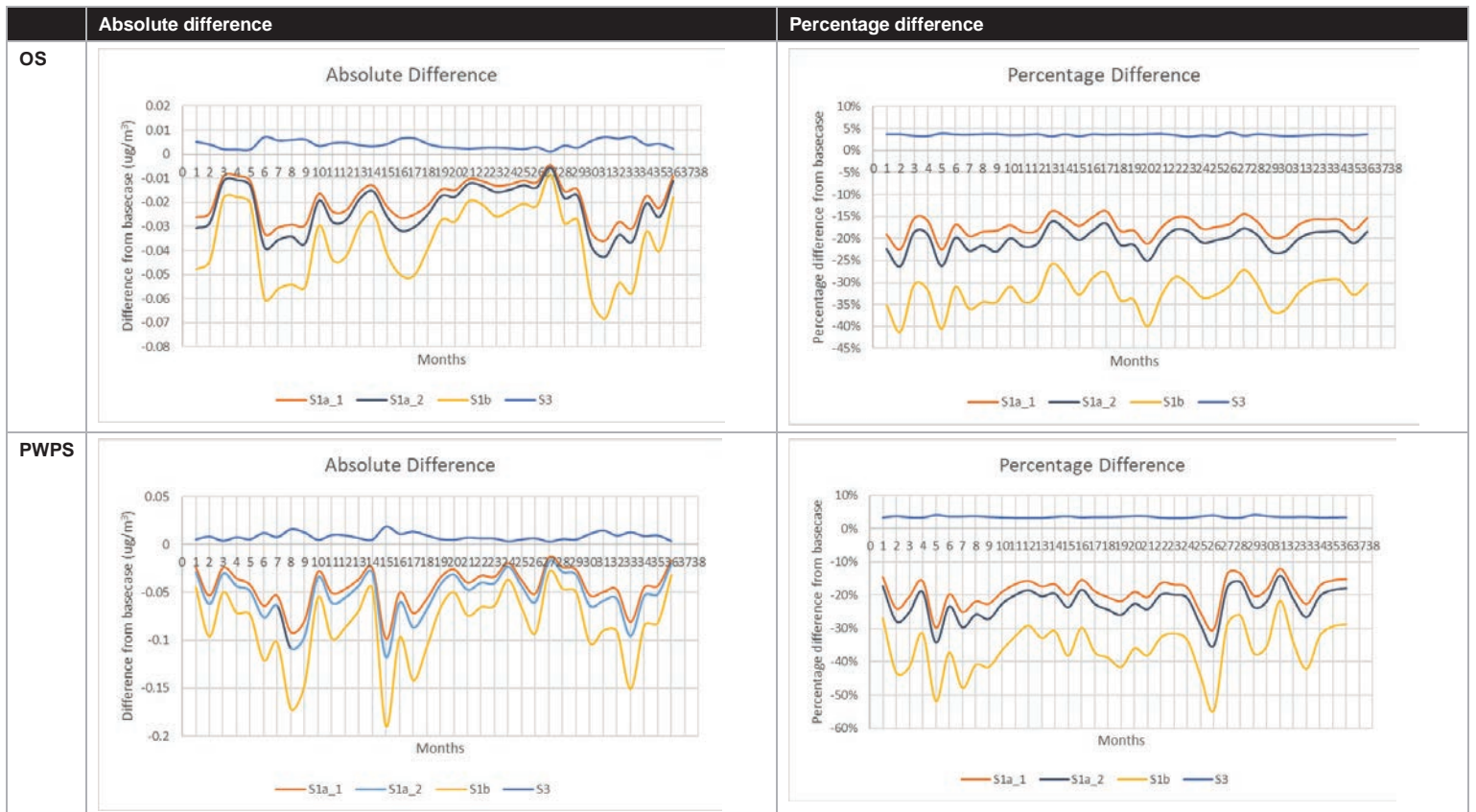

Figure 49 Pirie West Primary School – Zinc monthly average concentration box plot

Table 19 Predicted absolute and percentage difference - zinc

	Absolute difference	Percentage difference
ES	<p>The graph shows the absolute difference in zinc concentration from the basecase in $\mu\text{g}/\text{m}^3$ over 38 months. The y-axis ranges from -0.8 to 0.2. Scenario S3 (blue) remains near 0. S1a_1 (orange), S1a_2 (dark blue), and S1b (yellow) show significant fluctuations, generally staying between -0.2 and -0.8.</p>	<p>The graph shows the percentage difference from the basecase over 38 months. The y-axis ranges from -50% to 10%. Scenario S3 (blue) is consistently near 0%. S1a_1 (orange), S1a_2 (dark blue), and S1b (yellow) fluctuate between approximately -10% and -45%.</p>
BR	<p>The graph shows the absolute difference in zinc concentration from the basecase in $\mu\text{g}/\text{m}^3$ over 38 months. The y-axis ranges from -0.18 to 0.02. Scenario S3 (blue) is near 0. S1a_1 (orange), S1a_2 (dark blue), and S1b (yellow) fluctuate between -0.05 and -0.15.</p>	<p>The graph shows the percentage difference from the basecase over 38 months. The y-axis ranges from -40% to 10%. Scenario S3 (blue) is near 0%. S1a_1 (orange), S1a_2 (dark blue), and S1b (yellow) fluctuate between approximately -10% and -35%.</p>



7. Conclusion

GHD was engaged by Nyrstar to assess the air quality effects associated with the implementation of a pre-treatment plant at Nyrstar Port Pirie. The need for the assessment arose from recent plans for use of the now redundant sinter plant equipment to create a new process to pre-treat material for use in the blast furnace.

To assess the effects of the implementation of the pre-treatment plant, GHD referred to the predicted emission rates for the relevant species (Arsenic, Cadmium, PM₁₀, Lead and Zinc) as well as real time monitoring data for LIA provided by Nyrstar.

Meteorology data generated through CALMET was utilised within CALPUFF to predict the concentrations of each species at four ambient monitoring locations. The CALPUFF results for lead in the base-case scenario (scenario 2) were compared against monitoring data at each location to normalise emission estimates and assess the accuracy of the dispersion model. The results demonstrated that the CALPUFF model slightly overpredicted the monitoring results at locations closer to the site (Ellen Street and Boat Ramp) and underpredicted the monitoring results at locations further from the site (slightly at Oliver Street and greater underprediction at Pirie West Primary School).

Analysis was then undertaken to compare predicted results for each scenario (1a_1, 1a_2, 1b and 3) against the base-case (scenario 2). The general trend revealed that the decreased predicted concentrations for scenario 1a_1 (Pre-treatment with stockpiles - start), scenario 1a_2 (Pre-treatment with stockpiles – 18 months) and scenario 1b (No Pre-treatment with no stockpiles).

The 5% (lead) decrease for scenario 1a_1 and subsequent 10% (lead) decrease for scenario 1a_2 indicates that there is a predicted decrease in concentrations of arsenic, cadmium, PM₁₀, lead and zinc in the atmosphere over the 18 month period after implementation of the Pre-treatment Plant.

The decreased predicted concentrations for scenario 1b, which excludes the Pre-treatment Plant as well as stockpiles, will result in less community pollution in the long term.

Appendices

Appendix A

Scenario 1a_1 emission rates

Emissions to Air

Source ID	Description	PM10 Dust Emission rate (g/s)	Lead Emission rate (g/s)	Arsenic Emission rate (g/s)	Cadmium Emission rate (g/s)	Zinc Emission rate (g/s)	Percent Time of Emissions	Total PM10 Dust emissions (kg)	Total lead emissions (kg)	Total Arsenic emissions (kg)	Total Cadmium emissions (kg)	Total Zinc emissions (kg)
Point sources - stacks												
<i>Definition: Includes stack emissions under normal and abnormal operating conditions</i>												
<i>Objective: All capture systems in good condition, maintained and performing effectively. Best practice standards for gas cleaning equipment.</i>												
Normal Operating Conditions												
1	Point Source - Stacks - Normal Operations - Total	3.3581	0.7727	0.0567	0.0681	0.4501	90%	93,959	21,490	1,608	1,917	12,682
1.1	Blast Furnace Enclosure Baghouse Stack	0.1100	0.0658	0.0004	0.0014	0.0151	90%	3123	1868	13	39	428
1.2	5m Smelter Baghouse Flue	2.2594	0.3909	0.0550	0.0612	0.3642	90%	64,128	11,093	1,562	1,737	10,338
1.3	Pretreatment Plant Number 6 Scrubber	0.0835	0.0134	0.0002	0.0038	0.0032	80%	2,108	337	6	97	82
1.4	Combined Scrubber Pretreatment Plant	0.0154	0.0025	0.0000	0.0002	0.0002	80%	389	62.3	1	6	5
1.5	3m Refinery Flue	0.0575	0.0560	0.0004	0.0001	0.0071	90%	1,632	1,589	10	3	201
1.6	Acid Plant Stack	0.2169	0.0085	0.0001	0.0001	0.0031	89%	6080	239	4	3	87
1.7	Slag Fuming Main Baghouse Stack	0.4690	0.1888	0.0004	0.0008	0.0399	84%	12,349	4,971	9	21	1,050
1.8	Kilns Dust Recovery Combined Stack	0.1449	0.0469	0.0002	0.0004	0.0173	90%	4,114	1,330	4	11	492
1.9	SF Coal Mill Baghouse	0.0014	0.0000	0.0000	0.0000	0.0000	84%	37	0	0	0	0
1.10	TSL Coal Mill Baghouse											
1.11	Combustion Gas Vents - Total	0	0	0	0	0		0	0	0	0	0
1.9.1	Lead anode furnace								0.1			
1.9.2	To be identified											
Abnormal Operating Conditions												
2	Point source - stacks. Abnormal Operation - TOTAL	0	0	0	0	0		0	0	0	0	0
Point sources - boiler emissions												
<i>Definition</i>												
<i>Objective: All boiler emissions captured and cleaned before release (10+ years)</i>												
	Volume sources - boiler emissions	0.00	0.00	0.00	0.00	0.00	100%	63	0.00	0.00	0.01	0.24
3	Slag Fuming Furnaces											

Emissions to Air

Source ID	Description	PM10 Dust Emission rate (g/s)	Lead Emission rate (g/s)	Arsenic Emission rate (g/s)	Cadmium Emission rate (g/s)	Zinc Emission rate (g/s)	Percent Time of Emissions	Total PM10 Dust emissions (kg)	Total lead emissions (kg)	Total Arsenic emissions (kg)	Total Cadmium emissions (kg)	Total Zinc emissions (kg)
4	Primary Smelting Furnace											
5	Refinery											
6	Zinc Leach Plant - Presha Boiler	0.0020	0.0000	0.0000	0.0000	0.0000	100%	62.9600	0.0042	0.0017	0.0094	0.2444
7	SF Coal Mill Burner											

Volume sources - plant fugitives (field investigations)

Definitions: Process plant fugitive emissions not directly discharged by a point source e.g. stack or a hygiene system

Objective: Mitigate process plant fugitive emissions through - enclosing areas of problematic fugitive emissions - installation of hygiene systems - plant process control improvements - effective maintenance strategy of gas handling systems

Source ID	Description	PM10 Dust Emission rate (g/s)	Lead Emission rate (g/s)	Arsenic Emission rate (g/s)	Cadmium Emission rate (g/s)	Zinc Emission rate (g/s)	Percent Time of Emissions	Total PM10 Dust emissions (kg)	Total lead emissions (kg)	Total Arsenic emissions (kg)	Total Cadmium emissions (kg)	Total Zinc emissions (kg)
	Volume sources - plant fugitives (field investigations) - Normal Conditions - Total	3	2	0	0	1		62,706	19,786	570	585	19,091
8	TSL Area Fugitive Emissions - Total	0.77	0.95	0.02	0.02	0.19		433	531	13	13	106
8.1	TSL Furnace	0.28981	0.35560	0.00889	0.00889	0.07112	2%	183	224	5.6	5.6	44.9
8.2	TSL Tapping Floor											
8.3	TSL Lance Floor											
8.4	TSL Slag Caster vents	0.31	0.38	0.01	0.01	0.08	2%	196	240	6	6	48
8.5	TSL Valves and expansion joints											
8.6	TSL Slag Caster Discharge Chute	0.17	0.21	0.01	0.01	0.04	1%	54	66	2	2	13
9	Blast Furnace Fugitive Emissions - Total	0.4845	0.3039	0.0075	0.0188	0.1929	90%	13,751	8,626	214	533	5,474
9.1	Blast Furnace Secondary Enclosure	0.7345	0.4548	0.0114	0.0284	0.2842	2.5%	579	359	9	22	224
9.2	Blast Furnace - Granulator	0.0000	0.0039	0.0000	0.0000	0.0054	90%		111	0.8	0.4	152
9.3	Blast Furnace Tapping Floor	0.1265	0.0783	0.0020	0.0049	0.0490	90%	3,590	2,223	56	139	1,389

Emissions to Air

Source ID	Description	PM10 Dust Emission rate (g/s)	Lead Emission rate (g/s)	Arsenic Emission rate (g/s)	Cadmium Emission rate (g/s)	Zinc Emission rate (g/s)	Percent Time of Emissions	Total PM10 Dust emissions (kg)	Total lead emissions (kg)	Total Arsenic emissions (kg)	Total Cadmium emissions (kg)	Total Zinc emissions (kg)
9.4	Blast Furnace Forehearth											
9.5	Blast Furnace Burning In											
9.6	Blast Furnace Crane Aisle	0.0921	0.0570	0.0014	0.0036	0.0356	90%	2,614	1,619	40	101	1,012
9.7	Copper Drossing Furnace (CDF) - Furnace											
9.8	Copper Drossing Furnace (CDF) Recirculating Launder	0.0035	0.0022	0.0001	0.0001	0.0014	90%	99	62	2	4	38
9.9	Copper Drossing Furnace (CDF) Charge Chute	0.0001	0.0001	0.0000	0.0000	0.0000	90%	3	2	0	0	1
9.10	Blast Furnace Holding Pans and launders	0.0026	0.0016	0.0000	0.0001	0.0010	90%	74	46	1	3	29
9.11	Blast Furnace valves and expansion joints											
9.12	Short Rotary Furnace (SRF) - general											
9.13	Short Rotary Furnace (SRF) - tapping											
9.14	Bullion ladles	0.3796	0.2350	0.0059	0.0147	0.1469	18%	2,155	1,334	33	83	834
9.15	Slag ladles - waiting at BF											
10	Refinery Plant Fugitive Emissions - Total	0	0	0	0	0		4	2	0	0	0
10.1	Refinery Batch											
10.2	Refinery Batch - Liquefaction											
10.2.1	Liquefaction Kettles	0.002	0.0011	0.0000006	0.0000001	0.0000304	5%	3.1	1.8	0.001	0.000	0.048
10.3	Refinery KBA											

Emissions to Air

Source ID	Description	PM10 Dust Emission rate (g/s)	Lead Emission rate (g/s)	Arsenic Emission rate (g/s)	Cadmium Emission rate (g/s)	Zinc Emission rate (g/s)	Percent Time of Emissions	Total PM10 Dust emissions (kg)	Total lead emissions (kg)	Total Arsenic emissions (kg)	Total Cadmium emissions (kg)	Total Zinc emissions (kg)
10.4	Final Refining Pans	0.0005	0.0003	0.0000002	0.0000000	0.0000076	5%	0.8	0.4	0.000	0.000	0.012
10.4.1	Auto-drossers											
10.4.2	B7/B8 de-zincing	0.000	-	0.0000000	0.0000000	0.0000000	5%	0.0	0.0	0.000	0.000	0.000
10.4.3	B4 desilverising											
10.5	Refinery Final Products (Alloying & Casting)											
10.6	Precious Metals Refinery											
10.7	Refinery Caustic Bunker (Final refining pan cross bunker)											
10.8	Softener Slag Bunker											
11	Slag Fumer Plant Fugitive Emissions - Total	0.8826	0.3649	0.0114	0.0011	0.2965	84%	23,240	9,608	300	30	7,807
11.1	Slag Fuming Plant											
11.2	Slag Fumer Charge Port Venting											
11.2.1	Furnace Charge Floor - Cold Charges	0.0024	0.00	0.00	0.00	0.00	17%	12.6	5.2	0.2	0.1	4.2
11.3	Slag Fumer Tapping Floor	0.2692	0.11	0.00	0.00	0.09	17%	1,418	586	18	11	476
11.3.1	Granulation System							0	0	0	0	0
11.4	Slag Fumer Gas Train	0.0078	0.00	0.00	0.00	0.00	17%	41	17	1	0	14
11.4.1	Recuperators	0.0094	0.00	0.00	0.00	0.00	17%	50	20	1	0	17
11.4.2	Brick Flue	0.2680	0.11	0.00	0.00	0.09	17%	1,411	584	18	11	474

Emissions to Air

Source ID	Description	PM10 Dust Emission rate (g/s)	Lead Emission rate (g/s)	Arsenic Emission rate (g/s)	Cadmium Emission rate (g/s)	Zinc Emission rate (g/s)	Percent Time of Emissions	Total PM10 Dust emissions (kg)	Total lead emissions (kg)	Total Arsenic emissions (kg)	Total Cadmium emissions (kg)	Total Zinc emissions (kg)
11.4.3	Balloon Flue	0.0008	0.00	0.00	0.00	0.00	17%	4	2	0	0	1
11.5	Slag Fumer Baghouse	0.1271	0.05	0.00	0.00	0.04	17%	669	277	9	5	225
11.5.1	SF BH Screws	0.2288	0.09	0.00	0.00	0.08	17%	1,205	498	16	9	405
11.5.2	Raw fume pad	0.0077	0.00	0.00	0.00	0.00	100%	243	100	3	2	82
11.5.3	Raw fume baghouse											
11.5.4	Raw fume hopper											
11.6	Slag fumer ladles - waiting at Slag Fumer											
	Pretreatment Plant Fugitive Emissions - Total	0.496	0.243	0.008	0.008	0.122	2.0%	313	153	5	5	77
	Main Machine						80%					
	IMP Hopper	0.0757	0.01	0.0004	0.00038	0.00606	0%	0	0	0	0	0
	IMP Feed Hopper	0.0757	0.01	0.0004	0.00038	0.00606	0%	0	0	0	0	0
	Tip End	2.6520	0.42	0.0133	0.01326	0.21216	0.5%	418	67	2	2	33
12	Kilns Plant Fugitive Emissions - Total	1	0	0	0	0		24,966	866	38	5	5,628
12.1	Kilns Feed End											
12.2	Kilns Discharge End	0.0000	-	-	-	-	5%	0.0	0.0	0.000	0.000	0.000
12.3	Kilns Feed System											
12.4	Kilns Bagging Plant											
12.5	Kilns BK2 (1/2 height) container loading											
12.6	Kilns Road Hopper Loading											
12.7	Kilns Dust Recovery Plant (KDR)	0.0216	0.0058	0.0003	0.0001	0.0397	90%	612	166	8	2	1,128
12.8	KDR - Wind-blown dust	0.7723	0.0222	0.0010	0.0001	0.1427	100%	24,354	700	30	3	4,500
13	Copper Plant Fugitive Emissions - Total	0	0	0	0	0		0	0	0	0	0

Emissions to Air

Source ID	Description	PM10 Dust Emission rate (g/s)	Lead Emission rate (g/s)	Arsenic Emission rate (g/s)	Cadmium Emission rate (g/s)	Zinc Emission rate (g/s)	Percent Time of Emissions	Total PM10 Dust emissions (kg)	Total lead emissions (kg)	Total Arsenic emissions (kg)	Total Cadmium emissions (kg)	Total Zinc emissions (kg)
13.1	Copper Plant Ball Mill											
13.2	Copper Plant Feed System											
12.3	Copper Plant Leach Reactors											
12.4	Copper Plant SX											
12.5	Copper Plant Electrowinning Cells											
13	EAF Dust Washing Plant - Total	0	0	0	0	0		0	0	0	0	0
13.1	EAF Feed System											
13.2	EAF Plant											
Abnormal Operating Conditions												
14	Volume sources - plant fugitives (field investigations) - Abnormal Conditions - Total	0	0	0	0	0		0	0	0	0	0
Volume sources - Building Emissions (field investigations)												
<i>Definitions: Fugitive emissions not directly discharged by a point source e.g. stack or a hygiene system being emitted from building openings</i>												
<i>Objective: Mitigate plant fugitive emissions through - enclosures</i>												
	Volume sources - Building Emissions (field investigations) - Total	0.0013	0.00035	0.00000	0.00000	0.00	50%	20.5	5.6	0.08	0.00	0.00
15	TSL Building											
16	BF Shed											
17	Refinery Shed											
18	PMR Shed											

Emissions to Air

Source ID	Description	PM10 Dust Emission rate (g/s)	Lead Emission rate (g/s)	Arsenic Emission rate (g/s)	Cadmium Emission rate (g/s)	Zinc Emission rate (g/s)	Percent Time of Emissions	Total PM10 Dust emissions (kg)	Total lead emissions (kg)	Total Arsenic emissions (kg)	Total Cadmium emissions (kg)	Total Zinc emissions (kg)
19	Raw Fume Shed	0.0013	0.00	0.00	0.00	0.00	50%	20.5	5.6	0.08	0.00	0.00
20	Roast Fume Shed											
21	Copper Leach Building											
22	Copper Cellhouse Building											
23	Cadmium Plant Shed											
24	EAF Plant Shed											

Volume sources - plant fugitives (handbook estimations)

Definitions: Process plant fugitive emissions not directly discharged by a point source e.g. stack or a hygiene system - Estimated using handbook guidelines

Objective: Have no unmeasured emissions Mitigate process plant fugitive emissions through - enclosing areas of problematic fugitive emissions - installation of hygiene systems - plant process control improvements - effective maintenance strategy of gas handling systems

Source ID	Description	PM10 Dust Emission rate (g/s)	Lead Emission rate (g/s)	Arsenic Emission rate (g/s)	Cadmium Emission rate (g/s)	Zinc Emission rate (g/s)	Percent Time of Emissions	Total PM10 Dust emissions (kg)	Total lead emissions (kg)	Total Arsenic emissions (kg)	Total Cadmium emissions (kg)	Total Zinc emissions (kg)
Volume sources - plant fugitives (handbook estimations)		0.542	0.175	0.002	0.003	0.022		14,053	4,902	60	80	614
25	Lead Refinery	-	0.041	-	-	-	90%	0	1151	0	0	0
26	Casting - Lead	-	0.047	-	-	0.005	90%	0	1,343	0	0	142
27	Mixing Plant (EM refers to as "Charge Building")	0.068	0.006	0.000	0.000	0.001	89%	1,919	164	4	4	33
28	Pretreatment Plant - Main Machine	0.414	0.013	0.000	0.000	0.006	80%	10,449	315	8	8	158
29	Copper Drossing Furnace	0.019	0.018	0.000	0.001	-	90%	537	518	13	32	0
30	TSL Furnace Tapping Platform	0.041	0.050	0.001	0.001	0.010	89%	1148	1409	35	35	282

Volume sources - stockpile fugitives

Includes Fugitive emissions from stored process materials as well as handling including mixing, loading, transport, unloading, etc

Objective: All materials covered. Any handling activity controlled or under cover. 10 year goal - no external storage

Source ID	Description	PM10 Dust Emission rate (g/s)	Lead Emission rate (g/s)	Arsenic Emission rate (g/s)	Cadmium Emission rate (g/s)	Zinc Emission rate (g/s)	Percent Time of Emissions	Total PM10 Dust emissions (kg)	Total lead emissions (kg)	Total Arsenic emissions (kg)	Total Cadmium emissions (kg)	Total Zinc emissions (kg)
Volume sources - stockpile fugitives - Total		915	9	0	0	50		68,601	11,597	160	51.9	6,917
26	Stockpiles - Uncovered - Total	7	1	0	0	1		34,038	5,137	39	15	3,235
26.1	PIT/Crusher area	0.827	0.111	0.002	0.001	0.150	15%	3,835	517	11	3	694

Emissions to Air

Source ID	Description	PM10 Dust Emission rate (g/s)	Lead Emission rate (g/s)	Arsenic Emission rate (g/s)	Cadmium Emission rate (g/s)	Zinc Emission rate (g/s)	Percent Time of Emissions	Total PM10 Dust emissions (kg)	Total lead emissions (kg)	Total Arsenic emissions (kg)	Total Cadmium emissions (kg)	Total Zinc emissions (kg)
26.2	PGP stockpile	0.305	0.013	0.001	0.001	0.099	15%	1,413	62	6	3	458
26.3	LSLC stockpile	0.102	0.042	0.000	0.000	0.011	15%	471	193	1	2	52
26.4	BuLP stockpile	0.772	0.135	0.004	0.002	0.073	15%	3,580	628	21	8	336
26.5	TSL slag blocks & residue mixes stockpiles	1.378	0.798	0.000	0.000	0.160	15%	6,392	3,700	0	0	740
26.6	Andritz Stockpile											
26.7	Blacksand stockpile - working section	3.956	0.008	0.000	0.000	0.206	15%	18,348	37	0	0	954
27	Stockpiles - Covered - Total	0	0	0	0	0		0	0.0	0	0	0
27.1	Black sand stockpile - finished landform											
27.2	PGP stockpile											
28	Materials Handling	454	4	0	0	25		34,563	6,460	121	37	3,682
28.1	Normal Conditions	0	0	0	0	0		3,397	2,082	21	5	718
28.1.1	Ships loading/unloading	0.075	0.049	0.001	0.000	0.014	100%	2,368	1,557	20	4	448
28.1.2	Trains loading/unloading	0.000	0.000	0.000	0.000	0.000	100%	1.6	2.3	0.0	0.0	0.2
28.1.3	Trucks loading/unloading	0.025	0.016	0.000	0.000	0.006	100%	804	520	1	1	199
28.1.4	Trucks loading/unloading - Battery Bay											
28.1.5	Grit Blasting											
28.1.6	Debagging materials from bulka bags											
28.1.7	Tippler unloading											
28.1.8	BF Feed Preparation Operations											
28.1.9	Slag Fumer Mixing Pad	0.07080	0.0007	0.0000	0.0000	0.0226	10%	223	2.1	0	0	71
28.1.10	EAF Plant Deliveries											
28.2	Abnormal Conditions	453.5	3.8	0.1	0.0	24.5		31,166	4378.0	100.2	32.1	2964.4

Emissions to Air

Source ID	Description	PM10 Dust Emission rate (g/s)	Lead Emission rate (g/s)	Arsenic Emission rate (g/s)	Cadmium Emission rate (g/s)	Zinc Emission rate (g/s)	Percent Time of Emissions	Total PM10 Dust emissions (kg)	Total lead emissions (kg)	Total Arsenic emissions (kg)	Total Cadmium emissions (kg)	Total Zinc emissions (kg)
28.2.1	Ship unloading in high winds											
28.2.2	PGP stockpile, extreme winds	2.8	0.125	0.012	0.005	0.920	4.7%	4,209	185	19	8	1,364
28.2.3	LSLC stockpile, extreme winds	2.8	1.164	0.006	0.010	0.315	4.7%	4,209	1,726	8	15	467
28.2.4	BuLP stockpile, extreme winds	2.8	0.498	0.016	0.006	0.267	4.7%	4,209	739	24	9	396
28.2.5	Andritz Stockpile, extreme winds	3.1	1.147224	0.0	0.0	0.0	4.7%	4,602	1,700	49	0	13
28.2.6	Blacksand stockpile - working section, extreme winds	335.8	0.672			17.461	0.1%	10,590	21	-	-	551
28.2.7	Blacksand stockpile - covered, extreme winds	106.1	0.212			5.518	0.1%	3,347	7	-	-	174
28.2.8	Ad hoc campaigns for material sales											
Volume sources - vehicle emissions												
<i>Includes all wheel generated emissions, dust from roads, leakage and dusting from materials being transported</i>												
Objective: Optimised internal material logistics to minimise material movements, best practise cleaning technology, good surface condition on all roads												
36	Wheel generated emissions - General	0.357	0.153	0.003	0.001	0.059	100%	11,271	4,816	89	33.0	1,856
Total controlled emissions (kg)		3.4	0.8	0.1	0.1	0.5		94,022	21,490	1,608	1,917	12,682
Total fugitive emissions (kg)		919.1	11.1	0.2	0.1	50.8		156,652	41,106	879	750	28,478
Total emissions (kg)		922.4	11.9	0.3	0.2	51.3		250,674	62,597	2,488	2,667	41,160

Appendix B

Scenario 1a_2 emission rates

Emissions to Air

Source ID	Description	PM10 Dust Emission rate (g/s)	Lead Emission rate (g/s)	Arsenic Emission rate (g/s)	Cadmium Emission rate (g/s)	Zinc Emission rate (g/s)	Percent Time of Emissions	Total PM10 Dust emissions (kg)	Total lead emissions (kg)	Total Arsenic emissions (kg)	Total Cadmium emissions (kg)	Total Zinc emissions (kg)
Point sources - stacks												
<i>Definition: Includes stack emissions under normal and abnormal operating conditions</i>												
<i>Objective: All capture systems in good condition, maintained and performing effectively. Best practice standards for gas cleaning equipment.</i>												
Normal Operating Conditions												
1	Point Source - Stacks - Normal Operations - Total	3.3581	0.7727	0.0567	0.0681	0.4501	90%	93.023	21,341	1,606	1,876	12,649
1.1	Blast Furnace Enclosure Baghouse Stack	0.1100	0.0658	0.0004	0.0014	0.0151	90%	3123	1868	13	39	428
1.2	5m Smelter Baghouse Flue	2.2594	0.3909	0.0550	0.0612	0.3642	90%	64,128	11,093	1,562	1,737	10,338
1.3	Pretreatment Plant Number 6 Scrubber	0.0835	0.0134	0.0002	0.0038	0.0032	50%	1,317	211	4	61	51
1.4	Combined Scrubber Pretreatment Plant	0.0154	0.0025	0.0000	0.0002	0.0002	50%	243	38.9	0	4	3
1.5	3m Refinery Flue	0.0575	0.0560	0.0004	0.0001	0.0071	90%	1,632	1,589	10	3	201
1.6	Acid Plant Stack	0.2169	0.0085	0.0001	0.0001	0.0031	89%	6080	239	4	3	87
1.7	Slag Fuming Main Baghouse Stack	0.4690	0.1888	0.0004	0.0008	0.0399	84%	12,349	4,971	9	21	1,050
1.8	Kilns Dust Recovery Combined Stack	0.1449	0.0469	0.0002	0.0004	0.0173	90%	4,114	1,330	4	11	492
1.9	SF Coal Mill Baghouse	0.0014	0.0000	0.0000	0.0000	0.0000	84%	37	0	0	0	0
1.10	TSL Coal Mill Baghouse											
1.11	Combustion Gas Vents - Total	0	0	0	0	0		0	0	0	0	0
Abnormal Operating Conditions												
2	Point source - stacks. Abnormal Operation - TOTAL	0	0	0	0	0		0	0	0	0	0
2.1	Baghouse bag leaks	0	0	0	0	0		0	0	0	0	0
2.1.1	Blast Furnace Enclosure Baghouse Stack											
2.1.2	5m Smelter Baghouse Flue											

Emissions to Air

Source ID	Description	PM10 Dust Emission rate (g/s)	Lead Emission rate (g/s)	Arsenic Emission rate (g/s)	Cadmium Emission rate (g/s)	Zinc Emission rate (g/s)	Percent Time of Emissions	Total PM10 Dust emissions (kg)	Total lead emissions (kg)	Total Arsenic emissions (kg)	Total Cadmium emissions (kg)	Total Zinc emissions (kg)
2.1.2.1	North Baghouse											
2.1.2.2	South Baghouse											
2.1.2.3	East Baghouse											
2.1.3	Slag Fuming Main Baghouse Stack											
2.1.4	SF Coal Mill Baghouse											
2.1.5	TSL Coal Mill Baghouse											
2.2	Baghouse Start up (filter build up)	0	0	0	0	0		0	0	0	0	0
2.3	KDR dry cyclone cleaning	0	0	0	0	0		0	0	0	0	0
Point sources - boiler emissions												
<i>Definition</i>												
<i>Objective: All boiler emissions captured and cleaned before release (10+ years)</i>												
Volume sources - boiler emissions		0.00	0.00	0.00	0.00	0.00	100%	63	0.00	0.00	0.01	0.24
3	Slag Fuming Furnaces											
4	Primary Smelting Furnace											
5	Refinery											
6	Zinc Leach Plant - Presha Boiler	0.0020	0.0000	0.0000	0.0000	0.0000	100%	62.9600	0.0042	0.0017	0.0094	0.2444
7	SF Coal Mill Burner											
Volume sources - plant fugitives (field investigations)												
<i>Definitions: Process plant fugitive emissions not directly discharged by a point source e.g. stack or a hygiene system</i>												
<i>Objective: Mitigate process plant fugitive emissions through - enclosing areas of problematic fugitive emissions - installation of hygiene systems - plant process control improvements - effective maintenance strategy of gas handling systems</i>												
Volume sources - plant fugitives (field investigations) - Normal Conditions - Total		3	2	0	0	1		62,589	19,728	569	584	19,062
8	TSL Area Fugitive Emissions - Total	0.77	0.95	0.02	0.02	0.19		433	531	13	13	106

Emissions to Air

Source ID	Description	PM10 Dust Emission rate (g/s)	Lead Emission rate (g/s)	Arsenic Emission rate (g/s)	Cadmium Emission rate (g/s)	Zinc Emission rate (g/s)	Percent Time of Emissions	Total PM10 Dust emissions (kg)	Total lead emissions (kg)	Total Arsenic emissions (kg)	Total Cadmium emissions (kg)	Total Zinc emissions (kg)
8.1	TSL Furnace	0.28981	0.35560	0.00889	0.00889	0.07112	2%	163	224	5.6	5.6	44.9
8.2	TSL Tapping Floor											
8.3	TSL Lance Floor											
8.4	TSL Slag Caster vents	0.31	0.38	0.01	0.01	0.08	2%	196	240	6	6	48
8.5	TSL Valves and expansion joints											
8.6	TSL Slag Caster Discharge Chute	0.17	0.21	0.01	0.01	0.04	1%	54	66	2	2	13
9	Blast Furnace Fugitive Emissions - Total	0.4845	0.3039	0.0075	0.0188	0.1929	90%	13,751	8,626	214	533	5,474
9.1	Blast Furnace Secondary Enclosure	0.7345	0.4548	0.0114	0.0284	0.2842	2.5%	579	359	9	22	224
9.2	Blast Furnace - Granulator	0.0000	0.0039	0.0000	0.0000	0.0054	90%		111	0.8	0.4	152
9.3	Blast Furnace Tapping Floor	0.1265	0.0783	0.0020	0.0049	0.0490	90%	3,590	2,223	56	139	1,389
9.4	Blast Furnace Forehearth											
9.5	Blast Furnace Burning In											
9.6	Blast Furnace Crane Aisle	0.0921	0.0570	0.0014	0.0036	0.0356	90%	2,614	1,619	40	101	1,012
9.7	Copper Dressing Furnace (CDF) - Furnace											
9.8	Copper Dressing Furnace (CDF) Recirculating Launder	0.0035	0.0022	0.0001	0.0001	0.0014	90%	99	62	2	4	38
9.9	Copper Dressing Furnace (CDF) Charge Chute	0.0001	0.0001	0.0000	0.0000	0.0000	90%	3	2	0	0	1

Emissions to Air

Source ID	Description	PM10 Dust Emission rate (g/s)	Lead Emission rate (g/s)	Arsenic Emission rate (g/s)	Cadmium Emission rate (g/s)	Zinc Emission rate (g/s)	Percent Time of Emissions	Total PM10 Dust emissions (kg)	Total lead emissions (kg)	Total Arsenic emissions (kg)	Total Cadmium emissions (kg)	Total Zinc emissions (kg)
9.10	Blast Furnace Holding Pans and launders	0.0026	0.0016	0.0000	0.0001	0.0010	90%	74	46	1	3	29
9.11	Blast Furnace valves and expansion joints											
9.12	Short Rotary Furnace (SRF) - general											
9.13	Short Rotary Furnace (SRF) - tapping											
9.14	Bullion ladles	0.3796	0.2350	0.0059	0.0147	0.1469	18%	2,155	1,334	33	83	834
9.15	Slag ladles - waiting at BF											
10	Refinery Plant Fugitive Emissions - Total	0	0	0	0	0		4	2	0	0	0
11	Slag Fumer Plant Fugitive Emissions - Total	0.8826	0.3649	0.0114	0.0011	0.2965	84%	23,240	9,608	300	30	7,807
	Pretreatment Plant Fugitive Emissions - Total	0.310	0.152	0.005	0.005	0.076	2.0%	195	96	3	3	48
	Main Machine						50%					
	IMP Hopper	0.0757	0.01	0.0004	0.00038	0.00606	0%	0	0	0	0	0
	IMP Fused Hopper	0.0757	0.01	0.0004	0.00038	0.00606	0%	0	0	0	0	0
	Tip End	2.6520	0.42	0.0133	0.01326	0.21216	0.5%	418	67	2	2	33
12	Kilns Plant Fugitive Emissions - Total	1	0	0	0	0		24,966	866	38	5	5,628
13	Copper Plant Fugitive Emissions - Total	0	0	0	0	0		0	0	0	0	0
13	EAF Dust Washing Plant - Total	0	0	0	0	0		0	0	0	0	0
Abnormal Operating Conditions												
14	Volume sources - plant fugitives (field investigations) - Abnormal Conditions - Total	0	0	0	0	0		0	0	0	0	0
Volume sources - Building Emissions (field investigations)												
<i>Definitions: Fugitive emissions not directly discharged by a point source e.g. stack or a hygiene system being emitted from building openings</i>												
<i>Objective: Mitigate plant fugitive emissions through - enclosures</i>												
	Volume sources - Building Emissions (field investigations) - Total	0.0013	0.00035	0.00000	0.00000	0.00	50%	20.5	5.6	0.08	0.00	0.00
15	TSL Building											

Emissions to Air

Source ID	Description	PM10 Dust Emission rate (g/s)	Lead Emission rate (g/s)	Arsenic Emission rate (g/s)	Cadmium Emission rate (g/s)	Zinc Emission rate (g/s)	Percent Time of Emissions	Total PM10 Dust emissions (kg)	Total lead emissions (kg)	Total Arsenic emissions (kg)	Total Cadmium emissions (kg)	Total Zinc emissions (kg)
16	BF Shed											
17	Refinery Shed											
18	PMR Shed											
19	Raw Fume Shed	0.0013	0.00	0.00	0.00	0.00	50%	20.5	5.6	0.08	0.00	0.00
20	Roast Fume Shed											
21	Copper Leach Building											
22	Copper Cellhouse Building											
23	Cadmium Plant Shed											
24	EAF Plant Shed											

Volume sources - plant fugitives (handbook estimations)

Definitions: Process plant fugitive emissions not directly discharged by a point source e.g. stack or a hygiene system - Estimated using handbook guidelines

Objective: Have no unmeasured emissions/Mitigate process plant fugitive emissions through - enclosing areas of problematic fugitive emissions - installation of hygiene systems - plant process control improvements - effective maintenance strategy of gas handling systems

Volume sources - plant fugitives (handbook estimations)	PM10 Dust Emission rate (g/s)	Lead Emission rate (g/s)	Arsenic Emission rate (g/s)	Cadmium Emission rate (g/s)	Zinc Emission rate (g/s)	Percent Time of Emissions	Total PM10 Dust emissions (kg)	Total lead emissions (kg)	Total Arsenic emissions (kg)	Total Cadmium emissions (kg)	Total Zinc emissions (kg)
25 Lead Refinery	0.542	0.175	0.002	0.003	0.022		10,135	4,783	57	77	555
25 Lead Refinery	-	0.041	-	-	-	90%	0	1151	0	0	0
26 Casting - Lead	-	0.047	-	-	0.005	90%	0	1,343	0	0	142
27 Mixing Plant (EM refers to as "Charge Building")	0.068	0.006	0.000	0.000	0.001	89%	1,919	164	4	4	33
28 Pretreatment Plant - Main Machine	0.414	0.013	0.000	0.000	0.006	50%	6,531	197	5	5	99
29 Copper Dressing Furnace	0.019	0.018	0.000	0.001	-	90%	537	518	13	32	0

Emissions to Air

Source ID	Description	PM10 Dust Emission rate (g/s)	Lead Emission rate (g/s)	Arsenic Emission rate (g/s)	Cadmium Emission rate (g/s)	Zinc Emission rate (g/s)	Percent Time of Emissions	Total PM10 Dust emissions (kg)	Total lead emissions (kg)	Total Arsenic emissions (kg)	Total Cadmium emissions (kg)	Total Zinc emissions (kg)
30	TSL Furnace Tapping Platform	0.041	0.050	0.001	0.001	0.010	89%	1148	1409	35	35	282

Volume sources - stockpile fugitives

Includes Fugitive emissions from stored process materials as well as handling including mixing, loading, transport, unloading, etc
Objective: All materials covered. Any handling activity controlled or under cover. 10 year goal - no external storage

Volume sources - stockpile fugitives - Total		914	9	0	0	50		65,843	10,278	158	50.4	6,500
Stockpiles - Uncovered - Total		7	1	0	0	1		31,279	3,819	37	13	2,818
26.1	PIT/Crusher area	0.827	0.111	0.002	0.001	0.150	15%	3,835	517	11	3	694
26.2	PGP stockpile	0.203	0.009	0.001	0.000	0.066	15%	942	41	4	2	305
26.3	LSLC stockpile	0.068	0.028	0.000	0.000	0.008	15%	314	129	1	1	35
26.4	BuLP stockpile	0.772	0.135	0.004	0.002	0.073	15%	3,580	628	21	8	336
26.5	TSL slag blocks & residue mixes stockpiles	0.919	0.532	0.000	0.000	0.106	15%	4,261	2,467	0	0	493
26.6	Andritz Stockpile											
26.7	Blacksand stockpile - working section	3.956	0.008	0.000	0.000	0.206	15%	18,348	37	0	0	954
Stockpiles - Covered - Total		0	0	0	0	0		0	0.0	0	0	0
27.1	Black sand stockpile - finished landform											
27.2	PGP stockpile											
28	Materials Handling	454	4	0	0	25		34,563	6,460	121	37	3,682
Normal Conditions		0	0	0	0	0		3,397	2,082	21	5	718
28.1.1	Ships loading/unloading	0.075	0.049	0.001	0.000	0.014	100%	2,368	1,557	20	4	448
28.1.2	Trains loading/unloading	0.000	0.000	0.000	0.000	0.000	100%	1.6	2.3	0.0	0.0	0.2
28.1.3	Trucks loading/unloading	0.025	0.016	0.000	0.000	0.006	100%	804	520	1	1	199
28.1.4	Trucks loading/unloading - Battery Bay											
28.1.5	Grit Blasting											
28.1.6	Debagging materials from bulka bags											
28.1.7	Tippler unloading											

Emissions to Air

Source ID	Description	PM10 Dust Emission rate (g/s)	Lead Emission rate (g/s)	Arsenic Emission rate (g/s)	Cadmium Emission rate (g/s)	Zinc Emission rate (g/s)	Percent Time of Emissions	Total PM10 Dust emissions (kg)	Total lead emissions (kg)	Total Arsenic emissions (kg)	Total Cadmium emissions (kg)	Total Zinc emissions (kg)
28.1.8	BF Feed Preparation Operations											
28.1.9	Slag Fumer Mixing Pad	0.07080	0.0007	0.0000	0.0000	0.0226	10%	223	2.1	0	0	71
28.1.10	EAF Plant Deliveries											
28.2	Abnormal Conditions	453.5	3.8	0.1	0.0	24.5		31,166	4378.0	100.2	32.1	2964.4
28.2.1	Ship unloading in high winds											
28.2.2	PGP stockpile, extreme winds	2.8	0.125	0.012	0.005	0.920	4.7%	4,209	185	19	8	1,364
28.2.3	LSLC stockpile, extreme winds	2.8	1.164	0.006	0.010	0.315	4.7%	4,209	1,726	8	15	467
28.2.4	BuLP stockpile, extreme winds	2.8	0.498	0.016	0.006	0.267	4.7%	4,209	739	24	9	396
28.2.5	Andritz Stockpile, extreme winds	3.1	1.147224	0.0	0.0	0.0	4.7%	4,602	1,700	49	0	13
28.2.6	Blacksand stockpile - working section, extreme winds	335.8	0.672			17.461	0.1%	10,590	21	-	-	551
28.2.7	Blacksand stockpile - covered, extreme winds	106.1	0.212			5.518	0.1%	3,347	7	-	-	174
28.2.8	Ad hoc campaigns for material sales											

Volume sources - vehicle emissions

Includes all wheel generated emissions, dust from roads, leakage and dusting from materials being transported

Objective: Optimised internal material logistics to minimise material movements, best practise cleaning technology, good surface condition on all roads

36	Wheel generated emissions - General	0.357	0.153	0.003	0.001	0.059	100%	11,271	4,816	89	33.0	1,856
----	-------------------------------------	-------	-------	-------	-------	-------	------	--------	-------	----	------	-------

Heavy Use Roads

36	Wheel generated emissions - Haul Roads - Total	0	0	0	0	0		0	0	0	0	0
36.1	Wheel generated emissions - Heavy Use - Unsealed Roads	0	0	0	0	0		0	0	0	0	0
36.2	Wheel generated emissions - Heavy Use - Sealed Roads	0	0	0	0	0		0	0	0	0	0

Medium Use Roads

37	Wheel generated emissions - Medium Use Roads - Total	0	0	0	0	0		0	0	0	0	0
37.1	Wheel generated emissions - Medium Use - Unsealed Roads	0	0	0	0	0		0	0	0	0	0
37.2	Wheel generated emissions - Medium Use - Sealed Roads	0	0	0	0	0		0	0	0	0	0

Low Use Roads

38	Wheel generated emissions - Low Use Roads - Total	0	0	0	0	0		8	0	0	0	2
38.1	Wheel generated emissions - Low Use - Unsealed Roads	0	0	0	0	0		8	0	0	0	2
38.2	Wheel generated emissions - Low Use - Sealed Roads	0	0	0	0	0		0	0	0	0	0

Total controlled emissions (kg)		3.4	0.8	0.1	0.1	0.5		93,086	21,341	1,606	1,878	12,650
Total fugitive emissions (kg)		918.3	10.7	0.2	0.1	50.7		149,858	39,612	872	744	27,973
Total emissions (kg)		921.7	11.5	0.3	0.2	51.1		242,943	60,953	2,478	2,622	40,623

Appendix C

Scenario 1b emission rates

Emissions to Air

Source ID	Description	PM10 Dust Emission rate (g/s)	Lead Emission rate (g/s)	Arsenic Emission rate (g/s)	Cadmium Emission rate (g/s)	Zinc Emission rate (g/s)	Percent Time of Emissions	Total PM10 Dust emissions (kg)	Total lead emissions (kg)	Total Arsenic emissions (kg)	Total Cadmium emissions (kg)	Total Zinc emissions (kg)
Point sources - stacks												
<i>Definition: Includes stack emissions under normal and abnormal operating conditions</i>												
<i>Objective: All capture systems in good condition, maintained and performing effectively. Best practice standards for gas cleaning equipment.</i>												
Normal Operating Conditions												
1	Point Source - Stacks - Normal Operations - Total	3.2591	0.7568	0.0565	0.0640	0.4467	90%	91,462	21,091	1,602	1,814	12,595
1.1	Blast Furnace Enclosure Baghouse Stack	0.1100	0.0658	0.0004	0.0014	0.0151	90%	3123	1868	13	39	428
1.2	5m Smelter Baghouse Flue	2.2594	0.3909	0.0550	0.0612	0.3642	90%	64,128	11,093	1,562	1,737	10,338
1.3	Pretreatment Plant Number 6 Scrubber						0%	0	0	0	0	0
1.4	Combined Scrubber Pretreatment Plant						0%	0	0	0	0	0
1.5	3m Refinery Flue	0.0575	0.0560	0.0004	0.0001	0.0071	90%	1,632	1,589	10	3	201
1.6	Acid Plant Stack	0.2169	0.0085	0.0001	0.0001	0.0031	89%	6080	239	4	3	87
1.7	Slag Fuming Main Baghouse Stack	0.4690	0.1888	0.0004	0.0008	0.0399	84%	12,349	4,971	9	21	1,050
1.8	Kilns Dust Recovery Combined Stack	0.1449	0.0469	0.0002	0.0004	0.0173	90%	4,114	1,330	4	11	492
1.9	SF Coal Mill Baghouse	0.0014	0.0000	0.0000	0.0000	0.0000	84%	37	0	0	0	0
1.10	TSL Coal Mill Baghouse											
1.11	Combustion Gas Vents - Total	0	0	0	0	0		0	0	0	0	0
Abnormal Operating Conditions												
2	Point source - stacks. Abnormal Operation - TOTAL	0	0	0	0	0		0	0	0	0	0
Point sources - boiler emissions												
<i>Definition</i>												
<i>Objective: All boiler emissions captured and cleaned before release (10+ years)</i>												
Volume sources - boiler emissions												
3	Slag Fuming Furnaces	0.00	0.00	0.00	0.00	0.00	100%	63	0.00	0.00	0.01	0.24
4	Primary Smelting Furnace											
5	Refinery											

Emissions to Air

Source ID	Description	PM10 Dust Emission rate (g/s)	Lead Emission rate (g/s)	Arsenic Emission rate (g/s)	Cadmium Emission rate (g/s)	Zinc Emission rate (g/s)	Percent Time of Emissions	Total PM10 Dust emissions (kg)	Total lead emissions (kg)	Total Arsenic emissions (kg)	Total Cadmium emissions (kg)	Total Zinc emissions (kg)
6	Zinc Leach Plant - Presha Boiler	0.0020	0.0000	0.0000	0.0000	0.0000	100%	62.9600	0.0042	0.0017	0.0094	0.2444
7	SF Coal Mill Burner											

Volume sources - plant fugitives (field investigations)

Definitions: Process plant fugitive emissions not directly discharged by a point source e.g. stack or a hygiene system
 Objective: Mitigate process plant fugitive emissions through - enclosing areas of problematic fugitive emissions - installation of hygiene systems - plant process control improvements - effective maintenance strategy of gas handling systems

Source ID	Description	PM10 Dust Emission rate (g/s)	Lead Emission rate (g/s)	Arsenic Emission rate (g/s)	Cadmium Emission rate (g/s)	Zinc Emission rate (g/s)	Percent Time of Emissions	Total PM10 Dust emissions (kg)	Total lead emissions (kg)	Total Arsenic emissions (kg)	Total Cadmium emissions (kg)	Total Zinc emissions (kg)
Volume sources - plant fugitives (field investigations) - Normal Conditions - Total												
8	TSL Area Fugitive Emissions - Total	0.77	0.95	0.02	0.02	0.19		433	531	13	13	106
8.1	TSL Furnace	0.28981	0.35560	0.00889	0.00889	0.07112	2%	183	224	5.6	5.6	44.9
8.2	TSL Tapping Floor											
8.3	TSL Lance Floor											
8.4	TSL Slag Caster vents	0.31	0.38	0.01	0.01	0.08	2%	196	240	6	6	48
8.5	TSL Valves and expansion joints											
8.6	TSL Slag Caster Discharge Chute	0.17	0.21	0.01	0.01	0.04	1%	54	66	2	2	13
9	Blast Furnace Fugitive Emissions - Total	0.5620	0.3519	0.0087	0.0218	0.2229	90%	15,951	9,988	248	618	6,325
9.1	Blast Furnace Secondary Enclosure	0.7345	0.4548	0.0114	0.0284	0.2842	2.9%	672	416	10	26	260
9.2	Blast Furnace - Granulator	0.0000	0.0039	0.0000	0.0000	0.0054	90%		111	0.8	0.4	152
9.3	Blast Furnace Tapping Floor	0.1265	0.0783	0.0020	0.0049	0.0490	90%	3,590	2,223	56	139	1,389
9.4	Blast Furnace Forehearth											
9.5	Blast Furnace Burning In											

Emissions to Air

Source ID	Description	PM10 Dust Emission rate (g/s)	Lead Emission rate (g/s)	Arsenic Emission rate (g/s)	Cadmium Emission rate (g/s)	Zinc Emission rate (g/s)	Percent Time of Emissions	Total PM10 Dust emissions (kg)	Total lead emissions (kg)	Total Arsenic emissions (kg)	Total Cadmium emissions (kg)	Total Zinc emissions (kg)
9.6	Blast Furnace Crane Aisle	0.0921	0.0570	0.0014	0.0036	0.0356	90%	2,614	1,619	40	101	1,012
9.7	Copper Drossing Furnace (CDF) - Furnace											
9.8	Copper Drossing Furnace (CDF) Recirculating Launder	0.0035	0.0022	0.0001	0.0001	0.0014	90%	99	62	2	4	38
9.9	Copper Drossing Furnace (CDF) Charge Chute	0.0001	0.0001	0.0000	0.0000	0.0000	90%	3	2	0	0	1
9.10	Blast Furnace Holding Pans and launders	0.0026	0.0016	0.0000	0.0001	0.0010	90%	74	46	1	3	29
9.11	Blast Furnace valves and expansion joints											
9.12	Short Rotary Furnace (SRF) - general											
9.13	Short Rotary Furnace (SRF) - tapping											
9.14	Bullion ladles	0.3796	0.2350	0.0059	0.0147	0.1469	18%	2,155	1,334	33	83	834
9.15	Slag ladles - waiting at BF											
10	Refinery Plant Fugitive Emissions - Total	0	0	0	0	0		4	2	0	0	0
10.1	Refinery Batch											
10.2	Refinery Batch - Liquation											
10.2.1	Liquation Kettles	0.002	0.0011	0.0000006	0.0000001	0.0000304	5%	3.1	1.8	0.001	0.000	0.048
10.3	Refinery KBA											
10.4	Final Refining Pans	0.0005	0.0003	0.0000002	0.0000000	0.0000076	5%	0.8	0.4	0.000	0.000	0.012
10.4.1	Auto-drossers											

Emissions to Air

Source ID	Description	PM10 Dust Emission rate (g/s)	Lead Emission rate (g/s)	Arsenic Emission rate (g/s)	Cadmium Emission rate (g/s)	Zinc Emission rate (g/s)	Percent Time of Emissions	Total PM10 Dust emissions (kg)	Total lead emissions (kg)	Total Arsenic emissions (kg)	Total Cadmium emissions (kg)	Total Zinc emissions (kg)
10.4.2	B7/B8 de-zincing	0.000	-	0.0000000	0.0000000	0.0000000	5%	0.0	0.0	0.000	0.000	0.000
10.4.3	B4 desilverising											
10.5	Refinery Final Products (Alloying & Casting)											
10.6	Precious Metals Refinery											
10.7	Refinery Caustic Bunker (Final refining pan dross bunker)											
10.8	Softener Slag Bunker											
11	Slag Fumer Plant Fugitive Emissions - Total	0.5214	0.2156	0.0067	0.0007	0.1751	84%	13,730	5,676	177	18	4,612
11.1	Slag Fuming Plant											
11.2	Slag Fumer Charge Port Venting											
11.2.1	Furnace Charge Floor - Cold Charges	0.0024	0.00	0.00	0.00	0.00	17%	12.6	5.2	0.2	0.1	4.2
11.3	Slag Fumer Tapping Floor	0.2692	0.11	0.00	0.00	0.09	17%	1,418	586	18	11	476
11.3.1	Granulation System							0	0	0	0	0
11.4	Slag Fumer Gas Train	0.0078	0.00	0.00	0.00	0.00	17%	41	17	1	0	14
11.4.1	Recuperators	0.0094	0.00	0.00	0.00	0.00	17%	50	20	1	0	17
11.4.2	Brick Flue	0.2680	0.11	0.00	0.00	0.09	17%	1,411	584	18	11	474
11.4.3	Balloon Flue	0.0008	0.00	0.00	0.00	0.00	17%	4	2	0	0	1
11.5	Slag Fumer Baghouse	0.1271	0.05	0.00	0.00	0.04	17%	669	277	9	5	225

Emissions to Air

Source ID	Description	PM10 Dust Emission rate (g/s)	Lead Emission rate (g/s)	Arsenic Emission rate (g/s)	Cadmium Emission rate (g/s)	Zinc Emission rate (g/s)	Percent Time of Emissions	Total PM10 Dust emissions (kg)	Total lead emissions (kg)	Total Arsenic emissions (kg)	Total Cadmium emissions (kg)	Total Zinc emissions (kg)
11.5.1	SF BH Screws	0.2288	0.09	0.00	0.00	0.08	17%	1,205	498	16	9	405
11.5.2	Raw fume pad	0.0077	0.00	0.00	0.00	0.00	100%	243	100	3	2	82
11.5.3	Raw fume baghouse											
11.5.4	Raw fume hopper											
11.6	Slag fumer ladles - waiting at Slag Fumer											
Pretreatment Plant Fugitive Emissions - Total							0.0%	0	0	0	0	0
Main Machine							0%					
	IMP Hopper	0.0757	0.01	0.0004	0.00038	0.00606	0%	0	0	0	0	0
	IMP Feed Hopper	0.0757	0.01	0.0004	0.00038	0.00606	0%	0	0	0	0	0
	Tip End	2.6520	0.42	0.0133	0.01326	0.21216	0.0%	0	0	0	0	0
12	Kilns Plant Fugitive Emissions - Total	1	0	0	0	0		24,966	866	38	5	5,628
12.1	Kilns Feed End											
12.2	Kilns Discharge End	0.0000	-	-	-	-	5%	0.0	0.0	0.000	0.000	0.000
12.3	Kilns Feed System											
12.4	Kilns Bagging Plant											
12.5	Kilns BK2 (1/2 height) container loading											
12.6	Kilns Road Hopper Loading											
12.7	Kilns Dust Recovery Plant (KDR)	0.0216	0.0058	0.0003	0.0001	0.0397	90%	612	166	8	2	1,128
12.8	KDR - Wind-blown dust	0.7723	0.0222	0.0010	0.0001	0.1427	100%	24,354	700	30	3	4,500
13	Copper Plant Fugitive Emissions - Total	0	0	0	0	0		0	0	0	0	0
13.1	Copper Plant Ball Mill											
13.2	Copper Plant Feed System											

Emissions to Air

Source ID	Description	PM10 Dust Emission rate (g/s)	Lead Emission rate (g/s)	Arsenic Emission rate (g/s)	Cadmium Emission rate (g/s)	Zinc Emission rate (g/s)	Percent Time of Emissions	Total PM10 Dust emissions (kg)	Total lead emissions (kg)	Total Arsenic emissions (kg)	Total Cadmium emissions (kg)	Total Zinc emissions (kg)
12.3	Copper Plant Leach Reactors											
12.4	Copper Plant SX											
12.5	Copper Plant Electrowinning Cells											
13	EAFF Dust Washing Plant - Total	0	0	0	0	0		0	0	0	0	0
13.1	EAFF Feed System											
13.2	EAFF Plant											
Abnormal Operating Conditions												
14	Volume sources - plant fugitives (field investigations) - Abnormal Conditions - Total	0	0	0	0	0		0	0	0	0	0
Volume sources - Building Emissions (field investigations)												
<i>Definitions: Fugitive emissions not directly discharged by a point source e.g. stack or a hygiene system being emitted from building openings</i>												
<i>Objective: Mitigate plant fugitive emissions through - enclosures</i>												
	Volume sources - Building Emissions (field investigations) - Total	0.0013	0.00035	0.00000	0.00000	0.00	50%	20.5	5.6	0.08	0.00	0.00
Volume sources - plant fugitives (handbook estimations)												
<i>Definitions: Process plant fugitive emissions not directly discharged by a point source e.g. stack or a hygiene system - Estimated using handbook guidelines</i>												
<i>Objective: Have no unmeasured emissionsMitigate process plant fugitive emissions through - enclosing areas of problematic fugitive emissions - installation of hygiene systems - plant process control improvements - effective maintenance strategy of gas handling systems</i>												
	Volume sources - plant fugitives (handbook estimations)	0.128	0.162	0.002	0.003	0.016		3,604	4,586	52	72	456
25	Lead Refinery	-	0.041	-	-	-	90%	0	1151	0	0	0
26	Casting - Lead	-	0.047	-	-	0.005	90%	0	1,343	0	0	142
27	Mixing Plant (EM refers to as "Charge Building")	0.068	0.006	0.000	0.000	0.001	89%	1,919	164	4	4	33
28	Pretreatment Plant - Main Machine						0%	0	0	0	0	0
29	Copper Dressing Furnace	0.019	0.018	0.000	0.001	-	90%	537	518	13	32	0
30	TSL Furnace Tapping Platform	0.041	0.050	0.001	0.001	0.010	89%	1148	1409	35	35	282
Volume sources - stockpile fugitives												
<i>Includes Fugitive emissions from stored process materials as well as handling including mixing, loading, transport, unloading, etc</i>												
<i>Objective: All materials covered. Any handling activity controlled or under cover. 10 year goal - no external storage</i>												
	Volume sources - stockpile fugitives - Total	911	8	0	0	49		35,123	1,663	21	4	2,211

Emissions to Air

Source ID	Description	PM10 Dust Emission rate (g/s)	Lead Emission rate (g/s)	Arsenic Emission rate (g/s)	Cadmium Emission rate (g/s)	Zinc Emission rate (g/s)	Percent Time of Emissions	Total PM10 Dust emissions (kg)	Total lead emissions (kg)	Total Arsenic emissions (kg)	Total Cadmium emissions (kg)	Total Zinc emissions (kg)
26	Stockpiles - Uncovered - Total	4	0	0	0	0		18,348	37	0	0	954
26.1	PIT/Crusher area	0.000	0.000	0.000	0.000	0.000	15%	0	0	0	0	0
26.2	PGP stockpile						0%	0	0	0	0	0
26.3	LSLC stockpile						0%	0	0	0	0	0
26.4	BuLP stockpile						0%	0	0	0	0	0
26.5	TSL slag blocks & residue mixes stockpiles	0.000	0.000	0.000	0.000	0.000	15%	0	0	0	0	0
26.6	Andritz Stockpile											
26.7	Blacksand stockpile - working section	3.956	0.008	0.000	0.000	0.206	15%	18,348	37	0	0	954
27	Stockpiles - Covered - Total	0	0	0	0	0		0	0	0	0	0
27.1	Black sand stockpile - finished landform											
27.2	PGP stockpile											
28	Materials Handling	454	4	0	0	25		16,776	1,626	21	4	1,257
28.1	Normal Conditions	0.151	0.050	0.001	0.000	0.037		2,742	1,562	20	4	532
28.1.1	Ships loading/unloading	0.075	0.049	0.001	0.000	0.014	100%	2,368	1,557	20	4	448
28.1.2	Trains loading/unloading	0.000	0.000	0.000	0.000	0.000	100%	1.6	2.3	0.0	0.0	0.2
28.1.3	Trucks loading/unloading	0.005	0.000	0.000	0.000	0.000	100%	148	1	0	0	13
28.1.4	Trucks loading/unloading - Battery Bay											
28.1.5	Grit Blasting											
28.1.6	Debagging materials from bulka bags											
28.1.7	Tippler unloading											
28.1.8	BF Feed Preparation Operations											
28.1.9	Slag Fumer Mixing Pad	0.07080	0.0007	0.0000	0.0000	0.0226	10%	223	2	0	0	71
28.1.10	EAF Plant Deliveries											

Emissions to Air

Source ID	Description	PM10 Dust Emission rate (g/s)	Lead Emission rate (g/s)	Arsenic Emission rate (g/s)	Cadmium Emission rate (g/s)	Zinc Emission rate (g/s)	Percent Time of Emissions	Total PM10 Dust emissions (kg)	Total lead emissions (kg)	Total Arsenic emissions (kg)	Total Cadmium emissions (kg)	Total Zinc emissions (kg)
28.2	Abnormal Conditions	453.5	3.8	0.1	0.0	24.5		14,034	64.1	1.0	0.0	725.0
28.2.1	Ship unloading in high winds											
28.2.2	PGP stockpile, extreme winds	2.8	0.125	0.012	0.005	0.920	0.0%	-	-	-	-	-
28.2.3	LSLC stockpile, extreme winds	2.8	1.164	0.006	0.010	0.315	0.0%	-	-	-	-	-
28.2.4	BuLP stockpile, extreme winds	2.8	0.498	0.016	0.006	0.267	0.0%	-	-	-	-	-
28.2.5	Andritz Stockpile, extreme winds	3.1	1.147224	0.0	0.0	0.0	0.1%	98	36	1	0	0
28.2.6	Blacksand stockpile - working section, extreme winds	335.8	0.672			17.461	0.1%	10,590	21	-	-	551
28.2.7	Blacksand stockpile - covered, extreme winds	106.1	0.212			5.518	0.1%	3,347	7	-	-	174
28.2.8	Ad hoc campaigns for material sales											
Volume sources - vehicle emissions												
<i>Includes all wheel generated emissions, dust from roads, leakage and dusting from materials being transported</i>												
<i>Objective: Optimised internal material logistics to minimise material movements, best practise cleaning technology, good surface condition on all roads</i>												
36	Wheel generated emissions - General	0.221	0.071	0.001	0.000	0.027	100%	6,965	2,245	41	15	864
Heavy Use Roads												
36	Wheel generated emissions - Haul Roads - Total	0	0	0	0	0		0	0	0	0	0
Medium Use Roads												
37	Wheel generated emissions - Medium Use Roads - Total	0	0	0	0	0		0	0	0	0	0
Low Use Roads												
38	Wheel generated emissions - Low Use Roads - Total	0	0	0	0	0		0	0	0	0	0
38.1	Wheel generated emissions - Low Use - Unsealed Roads	0	0	0	0	0		0	0	0	0	0
38.1.1	Landfill											
38.1.2	PGP Stockpile access						0%	0.0	0.00	0.00	0.00	0.00
38.1.3	BSEA Concrete Dump											
38.1.4	Other - Estimated											
38.2	Wheel generated emissions - Low Use - Sealed Roads	0	0	0	0	0		0	0	0	0	0
38.2.1	North Baghouse Road											
38.2.2	Sinter Road											
38.2.3	Mid Zinc Road											
38.2.4	Old Acid Lane											
38.2.5	Other - Estimated											
Total controlled emissions (kg)		3.3	0.8	0.1	0.1	0.4		91,525	21,091	1,602	1,814	12,595
Total fugitive emissions (kg)		914.3	9.5	0.2	0.1	50.1		100,797	25,563	591	745	20,202
Total emissions (kg)		917.6	10.3	0.2	0.2	50.5		192,322	46,654	2,193	2,559	32,798

Appendix D

Scenario 2 emission rates

Emissions to Air

Source ID	Description	PM10 Dust Emission rate (g/s)	Lead Emission rate (g/s)	Arsenic Emission rate (g/s)	Cadmium Emission rate (g/s)	Zinc Emission rate (g/s)	Percent Time of Emissions	Total PM10 Dust emissions (kg)	Total lead emissions (kg)	Total Arsenic emissions (kg)	Total Cadmium emissions (kg)	Total Zinc emissions (kg)
Point sources - stacks												
<i>Definition: Includes stack emissions under normal and abnormal operating conditions</i>												
<i>Objective: All capture systems in good condition, maintained and performing effectively. Best practice standards for gas cleaning equipment.</i>												
Normal Operating Conditions												
1	Point Source - Stacks - Normal Operations - Total	3.2591	0.7568	0.0565	0.0640	0.4467	90%	91,462	21,091	1,602	1,814	12,595
1.1	Blast Furnace Enclosure Baghouse Stack	0.1100	0.0658	0.0004	0.0014	0.0151	90%	3123	1868	13	39	428
1.2	5m Smelter Baghouse Flue	2.2594	0.3909	0.0550	0.0612	0.3642	90%	64,128	11,093	1,562	1,737	10,338
1.3	Pretreatment Plant Number 6 Scrubber						0%	0	0	0	0	0
1.4	Combined Scrubber Pretreatment Plant						0%	0	0	0	0	0
1.5	3m Refinery Flue	0.0575	0.0560	0.0004	0.0001	0.0071	90%	1,632	1,589	10	3	201
1.6	Acid Plant Stack	0.2169	0.0085	0.0001	0.0001	0.0031	89%	6080	239	4	3	87
1.7	Slag Furning Main Baghouse Stack	0.4690	0.1888	0.0004	0.0008	0.0399	84%	12,349	4,971	9	21	1,050
1.8	Kilns Dust Recovery Combined Stack	0.1449	0.0469	0.0002	0.0004	0.0173	90%	4,114	1,330	4	11	492
1.9	SF Coal Mill Baghouse	0.0014	0.0000	0.0000	0.0000	0.0000	84%	37	0	0	0	0
1.10	TSL Coal Mill Baghouse											
1.11	Combustion Gas Vents - Total	0	0	0	0	0		0	0	0	0	0
Abnormal Operating Conditions												
2	Point source - stacks. Abnormal Operation - TOTAL	0	0	0	0	0		0	0	0	0	0
Point sources - boiler emissions												
<i>Definition</i>												
<i>Objective: All boiler emissions captured and cleaned before release (10+ years)</i>												
	Volume sources - boiler emissions	0.00	0.00	0.00	0.00	0.00	100%	63	0.00	0.00	0.01	0.24
3	Slag Furning Furnaces											
4	Primary Smelting Furnace											

Emissions to Air

Source ID	Description	PM10 Dust Emission rate (g/s)	Lead Emission rate (g/s)	Arsenic Emission rate (g/s)	Cadmium Emission rate (g/s)	Zinc Emission rate (g/s)	Percent Time of Emissions	Total PM10 Dust emissions (kg)	Total lead emissions (kg)	Total Arsenic emissions (kg)	Total Cadmium emissions (kg)	Total Zinc emissions (kg)
5	Refinery											
6	Zinc Leach Plant - Presha Boiler	0.0020	0.0000	0.0000	0.0000	0.0000	100%	62.9600	0.0042	0.0017	0.0094	0.2444
7	SF Coal Mill Burner											

Volume sources - plant fugitives (field investigations)

Definitions: Process plant fugitive emissions not directly discharged by a point source e.g. stack or a hygiene system

Objective: Mitigate process plant fugitive emissions through - enclosing areas of problematic fugitive emissions - installation of hygiene systems - plant process control improvements - effective maintenance strategy of gas handling systems

Source ID	Description	PM10 Dust Emission rate (g/s)	Lead Emission rate (g/s)	Arsenic Emission rate (g/s)	Cadmium Emission rate (g/s)	Zinc Emission rate (g/s)	Percent Time of Emissions	Total PM10 Dust emissions (kg)	Total lead emissions (kg)	Total Arsenic emissions (kg)	Total Cadmium emissions (kg)	Total Zinc emissions (kg)
	Volume sources - plant fugitives (field investigations) - Normal Conditions - Total	3	2	0	0	1		65,342	21,815	620	690	20,070
8	TSL Area Fugitive Emissions - Total	0.85	1.04	0.03	0.03	0.21		1023	1255	31	31	251
8.1	TSL Furnace	0.28981	0.35560	0.00889	0.00889	0.07112	5%	457	561	14.0	14.0	112.1
8.2	TSL Tapping Floor											
8.3	TSL Lance Floor											
8.4	TSL Slag Caster vents	0.31	0.38	0.01	0.01	0.08	5%	489	600	15	15	120
8.5	TSL Valves and expansion joints											
8.6	TSL Slag Caster Discharge Chute	0.25	0.30	0.01	0.01	0.06	1%	77	95	2	2	19
9	Blast Furnace Fugitive Emissions - Total	0.5676	0.3553	0.0088	0.0220	0.2249	90%	16,109	10,084	250	624	6,384
9.1	Blast Furnace Secondary Enclosure	0.7345	0.4548	0.0114	0.0284	0.2842	2.9%	678	420	11	26	263
9.2	Blast Furnace - Granulator	0.0000	0.0039	0.0000	0.0000	0.0053	90%		109	0.8	0.4	150
9.3	Blast Furnace Tapping Floor	0.1265	0.0783	0.0020	0.0049	0.0490	90%	3,590	2,223	56	139	1,389

Emissions to Air

Source ID	Description	PM10 Dust Emission rate (g/s)	Lead Emission rate (g/s)	Arsenic Emission rate (g/s)	Cadmium Emission rate (g/s)	Zinc Emission rate (g/s)	Percent Time of Emissions	Total PM10 Dust emissions (kg)	Total lead emissions (kg)	Total Arsenic emissions (kg)	Total Cadmium emissions (kg)	Total Zinc emissions (kg)
9.4	Blast Furnace Forehearth											
9.5	Blast Furnace Burning In											
9.6	Blast Furnace Crane Aisle	0.0921	0.0570	0.0014	0.0036	0.0356	90%	2,614	1,619	40	101	1,012
9.7	Copper Drossing Furnace (CDF) - Furnace											
9.8	Copper Drossing Furnace (CDF) Recirculating Launder	0.0035	0.0022	0.0001	0.0001	0.0014	90%	99	62	2	4	38
9.9	Copper Drossing Furnace (CDF) Charge Chute	0.0001	0.0001	0.0000	0.0000	0.0000	90%	3	2	0	0	1
9.10	Blast Furnace Holding Pans and launders	0.0026	0.0016	0.0000	0.0001	0.0010	90%	74	46	1	3	29
9.11	Blast Furnace valves and expansion joints											
9.12	Short Rotary Furnace (SRF) - general											
9.13	Short Rotary Furnace (SRF) - tapping											
9.14	Bullion ladles	0.3796	0.2350	0.0059	0.0147	0.1469	18%	2,155	1,334	33	83	834
9.15	Slag ladles - waiting at BF											
10	Refinery Plant Fugitive Emissions - Total	0	0	0	0	0		4	2	0	0	0
10.1	Refinery Batch											
10.2	Refinery Batch - Liquation											
10.2.1	Liquation Kettles	0.002	0.0011	0.0000006	0.0000001	0.0000304	5%	3.1	1.8	0.001	0.000	0.048

Emissions to Air

Source ID	Description	PM10 Dust Emission rate (g/s)	Lead Emission rate (g/s)	Arsenic Emission rate (g/s)	Cadmium Emission rate (g/s)	Zinc Emission rate (g/s)	Percent Time of Emissions	Total PM10 Dust emissions (kg)	Total lead emissions (kg)	Total Arsenic emissions (kg)	Total Cadmium emissions (kg)	Total Zinc emissions (kg)
10.3	Refinery KBA											
10.4	Final Refining Pans	0.0005	0.0003	0.0000002	0.0000000	0.0000076	5%	0.8	0.4	0.000	0.000	0.012
10.4.1	Auto-drossers											
10.4.2	B7/B8 de-zincing	0.000	-	0.0000000	0.0000000	0.0000000	5%	0.0	0.0	0.000	0.000	0.000
10.4.3	B4 desilverising											
10.5	Refinery Final Products (Alloying & Casting)											
10.6	Precious Metals Refinery											
10.7	Refinery Caustic Bunker (Final refining pan dross bunker)											
10.8	Softener Slag Bunker											
11	Slag Fumer Plant Fugitive Emissions - Total	0.8826	0.3649	0.0114	0.0011	0.2965	84%	23,240	9,608	300	30	7,807
11.1	Slag Fuming Plant											
11.2	Slag Fumer Charge Port Venting											
11.2.1	Furnace Charge Floor - Cold Charges	0.0024	0.00	0.00	0.00	0.00	17%	12.6	5.2	0.2	0.1	4.2
11.3	Slag Fumer Tapping Floor	0.2692	0.11	0.00	0.00	0.09	17%	1,418	586	18	11	476
11.3.1	Granulation System							0	0	0	0	0
11.4	Slag Fumer Gas Train	0.0078	0.00	0.00	0.00	0.00	17%	41	17	1	0	14
11.4.1	Recuperators	0.0094	0.00	0.00	0.00	0.00	17%	50	20	1	0	17

Emissions to Air

Source ID	Description	PM10 Dust Emission rate (g/s)	Lead Emission rate (g/s)	Arsenic Emission rate (g/s)	Cadmium Emission rate (g/s)	Zinc Emission rate (g/s)	Percent Time of Emissions	Total PM10 Dust emissions (kg)	Total lead emissions (kg)	Total Arsenic emissions (kg)	Total Cadmium emissions (kg)	Total Zinc emissions (kg)
11.4.2	Brick Flue	0.2680	0.11	0.00	0.00	0.09	17%	1,411	584	18	11	474
11.4.3	Balloon Flue	0.0008	0.00	0.00	0.00	0.00	17%	4	2	0	0	1
11.5	Slag Fumer Baghouse	0.1271	0.05	0.00	0.00	0.04	17%	669	277	9	5	225
11.5.1	SF BH Screws	0.2288	0.09	0.00	0.00	0.08	17%	1,205	498	16	9	405
11.5.2	Raw fume pad	0.0077	0.00	0.00	0.00	0.00	100%	243	100	3	2	82
11.5.3	Raw fume baghouse											
11.5.4	Raw fume hopper											
11.6	Slag fumer ladies - waiting at Slag Fumer											
Pretreatment Plant Fugitive Emissions - Total							0.0%	0	0	0	0	0
Main Machine							0%					
	IMP Hopper	0.0757	0.02	0.0004	0.00038	0.00606	0%	0	0	0	0	0
	IMP Feed Hopper	0.0757	0.02	0.0004	0.00038	0.00606	0%	0	0	0	0	0
	Tip End	2.6520	0.53	0.0133	0.01326	0.21216	0.0%	0	0	0	0	0
12	Kilns Plant Fugitive Emissions - Total	1	0	0	0	0		24,966	866	38	5	5,628
12.1	Kilns Feed End											
12.2	Kilns Discharge End	0.0000	-	-	-	-	5%	0.0	0.0	0.000	0.000	0.000
12.3	Kilns Feed System											
12.4	Kilns Bagging Plant											
12.5	Kilns BK2 (1/2 height) container loading											
12.6	Kilns Road Hopper Loading											

Emissions to Air

Source ID	Description	PM10 Dust Emission rate (g/s)	Lead Emission rate (g/s)	Arsenic Emission rate (g/s)	Cadmium Emission rate (g/s)	Zinc Emission rate (g/s)	Percent Time of Emissions	Total PM10 Dust emissions (kg)	Total lead emissions (kg)	Total Arsenic emissions (kg)	Total Cadmium emissions (kg)	Total Zinc emissions (kg)
12.7	Kilns Dust Recovery Plant (KDR)	0.0216	0.0058	0.0003	0.0001	0.0397	90%	612	166	8	2	1,128
12.8	KDR - Wind-blown dust	0.7723	0.0222	0.0010	0.0001	0.1427	100%	24,354	700	30	3	4,500
13	Copper Plant Fugitive Emissions - Total	0	0	0	0	0		0	0	0	0	0
13.1	Copper Plant Ball Mill											
13.2	Copper Plant Feed System											
12.3	Copper Plant Leach Reactors											
12.4	Copper Plant SX											
12.5	Copper Plant Electrowinning Cells											
13	EAF Dust Washing Plant - Total	0	0	0	0	0		0	0	0	0	0
13.1	EAF Feed System											
13.2	EAF Plant											
Abnormal Operating Conditions												
14	Volume sources - plant fugitives (field investigations) - Abnormal Conditions - Total	0	0	0	0	0		0	0	0	0	0
Volume sources - Building Emissions (field investigations)												
<i>Definitions: Fugitive emissions not directly discharged by a point source e.g. stack or a hygiene system being emitted from building openings</i>												
<i>Objective: Mitigate plant fugitive emissions through - enclosures</i>												
	Volume sources - Building Emissions (field investigations) - Total	0.0013	0.00035	0.00000	0.00000	0.00	50%	20.5	5.6	0.08	0.00	0.00
15	TSL Building											
16	BF Shed											

Emissions to Air

Source ID	Description	PM10 Dust Emission rate (g/s)	Lead Emission rate (g/s)	Arsenic Emission rate (g/s)	Cadmium Emission rate (g/s)	Zinc Emission rate (g/s)	Percent Time of Emissions	Total PM10 Dust emissions (kg)	Total lead emissions (kg)	Total Arsenic emissions (kg)	Total Cadmium emissions (kg)	Total Zinc emissions (kg)
17	Refinery Shed											
18	PMR Shed											
19	Raw Fume Shed	0.0013	0.00	0.00	0.00	0.00	50%	20.5	5.6	0.08	0.00	0.00
20	Roast Fume Shed											
21	Copper Leach Building											
22	Copper Cellhouse Building											
23	Cadmium Plant Shed											
24	EAF Plant Shed											

Volume sources - plant fugitives (handbook estimations)

Definitions: Process plant fugitive emissions not directly discharged by a point source e.g. stack or a hygiene system - Estimated using handbook guidelines

Objective: Have no unmeasured emissionsMitigate process plant fugitive emissions through - enclosing areas of problematic fugitive emissions - installation of hygiene systems - plant process control improvements - effective maintenance strategy of gas handling systems

Volume sources - plant fugitives (handbook estimations)	0.128	0.162	0.002	0.003	0.016		3,604	4,586	52	72	456
25 Lead Refinery	-	0.041	-	-	-	90%	0	1151	0	0	0
26 Casting - Lead	-	0.047	-	-	0.005	90%	0	1,343	0	0	142
27 Mixing Plant (EM refers to as "Charge Building")	0.068	0.006	0.000	0.000	0.001	89%	1,919	164	4	4	33
28 Pretreatment Plant - Main Machine						0%	0	0	0	0	0
29 Copper Dressing Furnace	0.019	0.018	0.000	0.001	-	90%	537	518	13	32	0
30 TSL Furnace Tapping Platform	0.041	0.050	0.001	0.001	0.010	89%	1148	1409	35	35	282

Volume sources - stockpile fugitives

Emissions to Air

Source ID	Description	PM10 Dust Emission rate (g/s)	Lead Emission rate (g/s)	Arsenic Emission rate (g/s)	Cadmium Emission rate (g/s)	Zinc Emission rate (g/s)	Percent Time of Emissions	Total PM10 Dust emissions (kg)	Total lead emissions (kg)	Total Arsenic emissions (kg)	Total Cadmium emissions (kg)	Total Zinc emissions (kg)
<i>Includes Fugitive emissions from stored process materials as well as handling including mixing, loading, transport, unloading, etc</i>												
<i>Objective: All materials covered. Any handling activity controlled or under cover. 10 year goal - no external storage</i>												
	Volume sources - stockpile fugitives - Total	917	9	0	0	50		80,128	13,158	203	77	9,962
26	Stockpiles - Uncovered - Total	10	1	0	0	1		45,565	6,698	82	40	6,279
26.1	PIT/Crusher area	1.010	0.136	0.003	0.001	0.183	15%	4,687	632	14	4	849
26.2	PGP stockpile	2.031	0.089	0.009	0.004	0.658	15%	9,419	414	41	18	3,052
26.3	LSLC stockpile	0.677	0.278	0.001	0.002	0.075	15%	3,140	1,287	6	11	349
26.4	BuLP stockpile	0.772	0.135	0.004	0.002	0.073	15%	3,580	628	21	8	336
26.5	TSL slag blocks & residue mixes stockpiles	1.378	0.798	0.000	0.000	0.160	15%	6,392	3,700	0	0	740
26.6	Andritz Stockpile											
26.7	Blacksand stockpile - working section	3.956	0.008	0.000	0.000	0.206	15%	18,348	37	0	0	954
27	Stockpiles - Covered - Total	0	0	0	0	0		0	0	0	0	0
27.1	Black sand stockpile - finished landform											
27.2	PGP stockpile											
28	Materials Handling	454	4	0	0	25		34,563	6,460	121	37	3,682
28.1	Normal Conditions	0	0	0	0	0		3,397	2,082	21	5	718
28.1.1	Ships loading/unloading	0.075	0.049	0.001	0.000	0.014	100%	2,368	1,557	20	4	448
28.1.2	Trains loading/unloading	0.000	0.000	0.000	0.000	0.000	100%	1.6	2.3	0.0	0.0	0.2
28.1.3	Trucks loading/unloading	0.025	0.016	0.000	0.000	0.006	100%	804	520	1	1	199
28.1.4	Trucks loading/unloading - Battery Bay											
28.1.5	Grit Blasting											
28.1.6	Debagging materials from bulka bags											
28.1.7	Tippler unloading											
28.1.8	BF Feed Preparation Operations											

Emissions to Air

Source ID	Description	PM10 Dust Emission rate (g/s)	Lead Emission rate (g/s)	Arsenic Emission rate (g/s)	Cadmium Emission rate (g/s)	Zinc Emission rate (g/s)	Percent Time of Emissions	Total PM10 Dust emissions (kg)	Total lead emissions (kg)	Total Arsenic emissions (kg)	Total Cadmium emissions (kg)	Total Zinc emissions (kg)
28.1.9	Slag Fumer Mixing Pad	0.07080	0.0007	0.0000	0.0000	0.0226	10%	223	2	0	0	71
28.1.10	EAF Plant Deliveries											
28.2	Abnormal Conditions	453.5	3.8	0.1	0.0	24.5		31,166	4378.0	100.2	32.1	2964.4
28.2.1	Ship unloading in high winds											
28.2.2	PGP stockpile, extreme winds	2.8	0.125	0.012	0.005	0.920	4.7%	4,209	185	19	8	1,364
28.2.3	LSLC stockpile, extreme winds	2.8	1.164	0.006	0.010	0.315	4.7%	4,209	1,726	8	15	467
28.2.4	BuLP stockpile, extreme winds	2.8	0.498	0.016	0.006	0.267	4.7%	4,209	739	24	9	396
28.2.5	Andritz Stockpile, extreme winds	3.1	1.147224	0.0	0.0	0.0	4.7%	4,602	1,700	49	0	13
28.2.6	Blacksand stockpile - working section, extreme winds	335.8	0.672			17.461	0.1%	10,590	21	-	-	551
28.2.7	Blacksand stockpile - covered, extreme winds	106.1	0.212			5.518	0.1%	3,347	7	-	-	174
28.2.8	Ad hoc campaigns for material sales											
Volume sources - vehicle emissions												
<i>Includes all wheel generated emissions, dust from roads, leakage and dusting from materials being transported</i>												
<i>Objective: Optimised internal material logistics to minimise material movements, best practise cleaning technology, good surface condition on all roads</i>												
36	Wheel generated emissions - General	0.338	0.141	0.003	0.001	0.054	100%	10,648	4,448	82	30	1,712
Heavy Use Roads												
36	Wheel generated emissions - Haul Roads - Total	0	0	0	0	0		0	0	0	0	0
36.1	Wheel generated emissions - Heavy Use - Unsealed Roads	0	0	0	0	0		0	0	0	0	0
36.2	Wheel generated emissions - Heavy Use - Sealed Roads	0	0	0	0	0		0	0	0	0	0
Medium Use Roads												
37	Wheel generated emissions - Medium Use Roads - Total	0	0	0	0	0		0	0	0	0	0
37.1	Wheel generated emissions - Medium Use - Unsealed Roads	0	0	0	0	0		0	0	0	0	0
37.2	Wheel generated emissions - Medium Use - Sealed Roads	0	0	0	0	0		0	0	0	0	0
Low Use Roads												
38	Wheel generated emissions - Low Use Roads - Total	0	0	0	0	0		8	0	0	0	2
38.1	Wheel generated emissions - Low Use - Unsealed Roads	0	0	0	0	0		8	0	0	0	2
38.2	Wheel generated emissions - Low Use - Sealed Roads	0	0	0	0	0		0	0	0	0	0
<i>Total controlled emissions (kg)</i>		3.3	0.8	0.1	0.1	0.4		91,525	21,091	1,602	1,814	12,595
<i>Total fugitive emissions (kg)</i>		920.8	11.3	0.2	0.1	51.4		159,750	44,014	958	869	32,201
<i>Total emissions (kg)</i>		924.1	12.1	0.3	0.2	51.8		251,275	65,105	2,560	2,683	44,797

Appendix E

Scenario 3 emission rates

Emissions to Air

Source ID	Description	PM10 Dust Emission rate (g/s)	Lead Emission rate (g/s)	Arsenic Emission rate (g/s)	Cadmium Emission rate (g/s)	Zinc Emission rate (g/s)	Percent Time of Emissions	Total PM10 Dust emissions (kg)	Total lead emissions (kg)	Total Arsenic emissions (kg)	Total Cadmium emissions (kg)	Total Zinc emissions (kg)
Point sources - stacks												
<i>Definition: Includes stack emissions under normal and abnormal operating conditions</i>												
<i>Objective: All capture systems in good condition, maintained and performing effectively. Best practice standards for gas cleaning equipment.</i>												
Normal Operating Conditions												
1	Point Source - Stacks - Normal Operations - Total	3.3581	0.7727	0.0567	0.0681	0.4501	90%	92.086	21.191	1,604	1,840	12,617
1.1	Blast Furnace Enclosure Baghouse Stack	0.1100	0.0658	0.0004	0.0014	0.0151	90%	3123	1868	13	39	428
1.2	5m Smelter Baghouse Flue	2.2594	0.3909	0.0550	0.0612	0.3642	90%	64,128	11,093	1,562	1,737	10,338
1.3	Pretreatment Plant Number 6 Scrubber	0.0835	0.0134	0.0002	0.0038	0.0032	20%	527	84	1	24	20
1.4	Combined Scrubber Pretreatment Plant	0.0154	0.0025	0.0000	0.0002	0.0002	20%	97	16	0	1	1
1.5	3m Refinery Flue	0.0575	0.0560	0.0004	0.0001	0.0071	90%	1,632	1,589	10	3	201
1.6	Acid Plant Stack	0.2169	0.0085	0.0001	0.0001	0.0031	89%	6080	239	4	3	87
1.7	Slag Fuming Main Baghouse Stack	0.4690	0.1888	0.0004	0.0008	0.0399	84%	12,349	4,971	9	21	1,050
1.8	Kilns Dust Recovery Combined Stack	0.1449	0.0469	0.0002	0.0004	0.0173	90%	4,114	1,330	4	11	492
1.9	SF Coal Mill Baghouse	0.0014	0.0000	0.0000	0.0000	0.0000	84%	37	0	0	0	0
1.10	TSL Coal Mill Baghouse											
1.11	Combustion Gas Vents - Total	0	0	0	0	0		0	0	0	0	0
1.9.1	To be identified											
1.9.2	To be identified											
Abnormal Operating Conditions												
2	Point source - stacks. Abnormal Operation - TOTAL	0	0	0	0	0		0	0	0	0	0
Point sources - boiler emissions												
<i>Definition</i>												
<i>Objective: All boiler emissions captured and cleaned before release (10+ years)</i>												
Volume sources - boiler emissions												
3	Slag Fuming Furnaces	0.00	0.00	0.00	0.00	0.00	100%	63	0.00	0.00	0.01	0.24

Emissions to Air

Source ID	Description	PM10 Dust Emission rate (g/s)	Lead Emission rate (g/s)	Arsenic Emission rate (g/s)	Cadmium Emission rate (g/s)	Zinc Emission rate (g/s)	Percent Time of Emissions	Total PM10 Dust emissions (kg)	Total lead emissions (kg)	Total Arsenic emissions (kg)	Total Cadmium emissions (kg)	Total Zinc emissions (kg)
4	Primary Smelting Furnace											
5	Refinery											
6	Zinc Leach Plant - Presha Boiler	0.0020	0.0000	0.0000	0.0000	0.0000	100%	62.9600	0.0042	0.0017	0.0094	0.2444
7	SF Coal Mill Burner											

Volume sources - plant fugitives (field investigations)

Definitions: Process plant fugitive emissions not directly discharged by a point source e.g. stack or a hygiene system

Objective: Mitigate process plant fugitive emissions through - enclosing areas of problematic fugitive emissions - installation of hygiene systems - plant process control improvements - effective maintenance strategy of gas handling systems

Source ID	Description	PM10 Dust Emission rate (g/s)	Lead Emission rate (g/s)	Arsenic Emission rate (g/s)	Cadmium Emission rate (g/s)	Zinc Emission rate (g/s)	Percent Time of Emissions	Total PM10 Dust emissions (kg)	Total lead emissions (kg)	Total Arsenic emissions (kg)	Total Cadmium emissions (kg)	Total Zinc emissions (kg)
Volume sources - plant fugitives (field investigations) - Normal Conditions - Total		3	2	0	0	1		65,459	21,873	622	692	20,098
8	TSL Area Fugitive Emissions - Total	0.85	1.04	0.03	0.03	0.21		1023	1255	31	31	251
8.1	TSL Furnace	0.28981	0.35560	0.00889	0.00889	0.07112	5%	457	561	14.0	14.0	112.1
8.2	TSL Tapping Floor											
8.3	TSL Lance Floor											
8.4	TSL Slag Caster vents	0.31	0.38	0.01	0.01	0.08	5%	489	600	15	15	120
8.5	TSL Valves and expansion joints											
8.6	TSL Slag Caster Discharge Chute	0.25	0.30	0.01	0.01	0.06	1%	77	95	2	2	19
9	Blast Furnace Fugitive Emissions - Total	0.5676	0.3553	0.0088	0.0220	0.2249	90%	16,109	10,084	250	624	6,384
9.1	Blast Furnace Secondary Enclosure	0.7345	0.4548	0.0114	0.0284	0.2842	2.9%	678	420	11	26	263
9.2	Blast Furnace - Granulator	0.0000	0.0039	0.0000	0.0000	0.0053	90%		109	0.8	0.4	150
9.3	Blast Furnace Tapping Floor	0.1265	0.0783	0.0020	0.0049	0.0490	90%	3,590	2,223	56	139	1,389

Emissions to Air

Source ID	Description	PM10 Dust Emission rate (g/s)	Lead Emission rate (g/s)	Arsenic Emission rate (g/s)	Cadmium Emission rate (g/s)	Zinc Emission rate (g/s)	Percent Time of Emissions	Total PM10 Dust emissions (kg)	Total lead emissions (kg)	Total Arsenic emissions (kg)	Total Cadmium emissions (kg)	Total Zinc emissions (kg)
9.4	Blast Furnace Forehearth											
9.5	Blast Furnace Burning In											
9.6	Blast Furnace Crane Aisle	0.0921	0.0570	0.0014	0.0036	0.0356	90%	2,614	1,619	40	101	1,012
9.7	Copper Drossing Furnace (CDF) - Furnace											
9.8	Copper Drossing Furnace (CDF) Recirculating Launder	0.0035	0.0022	0.0001	0.0001	0.0014	90%	99	62	2	4	38
9.9	Copper Drossing Furnace (CDF) Charge Chute	0.0001	0.0001	0.0000	0.0000	0.0000	90%	3	2	0	0	1
9.10	Blast Furnace Holding Pans and launders	0.0026	0.0016	0.0000	0.0001	0.0010	90%	74	46	1	3	29
9.11	Blast Furnace valves and expansion joints											
9.12	Short Rotary Furnace (SRF) - general											
9.13	Short Rotary Furnace (SRF) - tapping											
9.14	Bullion ladles	0.3796	0.2350	0.0059	0.0147	0.1469	18%	2,155	1,334	33	83	834
9.15	Slag ladles - waiting at BF											
10	Refinery Plant Fugitive Emissions - Total	0	0	0	0	0		4	2	0	0	0
10.1	Refinery Batch											
10.2	Refinery Batch - Liquation											
10.2.1	Liquation Kettles	0.002	0.0011	0.0000006	0.0000001	0.0000304	5%	3.1	1.8	0.001	0.000	0.048
10.3	Refinery KBA											

Emissions to Air

Source ID	Description	PM10 Dust Emission rate (g/s)	Lead Emission rate (g/s)	Arsenic Emission rate (g/s)	Cadmium Emission rate (g/s)	Zinc Emission rate (g/s)	Percent Time of Emissions	Total PM10 Dust emissions (kg)	Total lead emissions (kg)	Total Arsenic emissions (kg)	Total Cadmium emissions (kg)	Total Zinc emissions (kg)
10.4	Final Refining Pans	0.0005	0.0003	0.0000002	0.0000000	0.0000076	5%	0.8	0.4	0.000	0.000	0.012
10.4.1	Auto-drossers											
10.4.2	B7/B8 de-zincing	0.000	-	0.0000000	0.0000000	0.0000000	5%	0.0	0.0	0.000	0.000	0.000
10.4.3	B4 desilverising											
10.5	Refinery Final Products (Alloying & Casting)											
10.6	Precious Metals Refinery											
10.7	Refinery Caustic Bunker (Final refining pan dross bunker)											
10.8	Softener Slag Bunker											
11	Slag Fumer Plant Fugitive Emissions - Total	0.8826	0.3649	0.0114	0.0011	0.2965	84%	23,240	9,608	300	30	7,807
11.1	Slag Fuming Plant											
11.2	Slag Fumer Charge Port Venting											
11.2.1	Furnace Charge Floor - Cold Charges	0.0024	0.00	0.00	0.00	0.00	17%	12.6	5.2	0.2	0.1	4.2
11.3	Slag Fumer Tapping Floor	0.2692	0.11	0.00	0.00	0.09	17%	1,418	586	18	11	476
11.3.1	Granulation System							0	0	0	0	0
11.4	Slag Fumer Gas Train	0.0078	0.00	0.00	0.00	0.00	17%	41	17	1	0	14
11.4.1	Recuperators	0.0094	0.00	0.00	0.00	0.00	17%	50	20	1	0	17
11.4.2	Brick Flue	0.2680	0.11	0.00	0.00	0.09	17%	1,411	584	18	11	474

Emissions to Air

Source ID	Description	PM10 Dust Emission rate (g/s)	Lead Emission rate (g/s)	Arsenic Emission rate (g/s)	Cadmium Emission rate (g/s)	Zinc Emission rate (g/s)	Percent Time of Emissions	Total PM10 Dust emissions (kg)	Total lead emissions (kg)	Total Arsenic emissions (kg)	Total Cadmium emissions (kg)	Total Zinc emissions (kg)
11.4.3	Balloon Flue	0.0008	0.00	0.00	0.00	0.00	17%	4	2	0	0	1
11.5	Slag Fumer Baghouse	0.1271	0.05	0.00	0.00	0.04	17%	669	277	9	5	225
11.5.1	SF BH Screws	0.2288	0.09	0.00	0.00	0.08	17%	1,205	498	16	9	405
11.5.2	Raw fume pad	0.0077	0.00	0.00	0.00	0.00	100%	243	100	3	2	82
11.5.3	Raw fume baghouse											
11.5.4	Raw fume hopper											
11.6	Slag fumer ladles - waiting at Slag Fumer											
	Pretreatment Plant Fugitive Emissions - Total	0.124	0.061	0.002	0.002	0.030	3.0%	117	58	2	2	29
	Main Machine						20%					
	IMP Hopper	0.0757	0.01	0.0004	0.00038	0.00606	8%	191	31	1	1	15
	IMP Feed Hopper	0.0757	0.01	0.0004	0.00038	0.00606	8%	191	31	1	1	15
	Tip End	2.6520	0.42	0.0133	0.01326	0.21216	1.0%	836	134	4	4	67
12	Kilns Plant Fugitive Emissions - Total	1	0	0	0	0		24,966	866	38	5	5,628
12.1	Kilns Feed End											
12.2	Kilns Discharge End	0.0000	-	-	-	-	5%	0.0	0.0	0.000	0.000	0.000
12.3	Kilns Feed System											
12.4	Kilns Bagging Plant											
12.5	Kilns BK2 (1/2 height) container loading											
12.6	Kilns Road Hopper Loading											
12.7	Kilns Dust Recovery Plant (KDR)	0.0216	0.0058	0.0003	0.0001	0.0397	90%	612	166	8	2	1,128
12.8	KDR - Wind-blown dust	0.7723	0.0222	0.0010	0.0001	0.1427	100%	24,354	700	30	3	4,500
13	Copper Plant Fugitive Emissions - Total	0	0	0	0	0		0	0	0	0	0

Emissions to Air

Source ID	Description	PM10 Dust Emission rate (g/s)	Lead Emission rate (g/s)	Arsenic Emission rate (g/s)	Cadmium Emission rate (g/s)	Zinc Emission rate (g/s)	Percent Time of Emissions	Total PM10 Dust emissions (kg)	Total lead emissions (kg)	Total Arsenic emissions (kg)	Total Cadmium emissions (kg)	Total Zinc emissions (kg)
13.1	Copper Plant Ball Mill											
13.2	Copper Plant Feed System											
12.3	Copper Plant Leach Reactors											
12.4	Copper Plant SX											
12.5	Copper Plant Electrowinning Cells											
13	EAF Dust Washing Plant - Total	0	0	0	0	0		0	0	0	0	0
13.1	EAF Feed System											
13.2	EAF Plant											
Abnormal Operating Conditions												
14	Volume sources - plant fugitives (field investigations) - Abnormal Conditions - Total	0	0	0	0	0		0	0	0	0	0
Volume sources - Building Emissions (field investigations)												
<i>Definitions: Fugitive emissions not directly discharged by a point source e.g. stack or a hygiene system being emitted from building openings</i>												
<i>Objective: Mitigate plant fugitive emissions through - enclosures</i>												
	Volume sources - Building Emissions (field investigations) - Total	0.0013	0.00035	0.00000	0.00000	0.00	50%	20.5	5.6	0.08	0.00	0.00
15	TSL Building											
16	BF Shed											
17	Refinery Shed											
18	PMR Shed											

Emissions to Air

Source ID	Description	PM10 Dust Emission rate (g/s)	Lead Emission rate (g/s)	Arsenic Emission rate (g/s)	Cadmium Emission rate (g/s)	Zinc Emission rate (g/s)	Percent Time of Emissions	Total PM10 Dust emissions (kg)	Total lead emissions (kg)	Total Arsenic emissions (kg)	Total Cadmium emissions (kg)	Total Zinc emissions (kg)
19	Raw Fume Shed	0.0013	0.00	0.00	0.00	0.00	50%	20.5	5.6	0.08	0.00	0.00
20	Roast Fume Shed											
21	Copper Leach Building											
22	Copper Cellhouse Building											
23	Cadmium Plant Shed											
24	EAF Plant Shed											

Volume sources - plant fugitives (handbook estimations)

Definitions: Process plant fugitive emissions not directly discharged by a point source e.g. stack or a hygiene system - Estimated using handbook guidelines
Objective: Have no unmeasured emissionsMitigate process plant fugitive emissions through - enclosing areas of problematic fugitive emissions - installation of hygiene systems - plant process control improvements - effective maintenance strategy of gas handling systems

Source ID	Description	PM10 Dust Emission rate (g/s)	Lead Emission rate (g/s)	Arsenic Emission rate (g/s)	Cadmium Emission rate (g/s)	Zinc Emission rate (g/s)	Percent Time of Emissions	Total PM10 Dust emissions (kg)	Total lead emissions (kg)	Total Arsenic emissions (kg)	Total Cadmium emissions (kg)	Total Zinc emissions (kg)
Volume sources - plant fugitives (handbook estimations)		0.542	0.175	0.002	0.003	0.022		6,217	4,665	54	74	496
25	Lead Refinery	-	0.041	-	-	-	90%	0	1151	0	0	0
26	Casting - Lead	-	0.047	-	-	0.005	90%	0	1,343	0	0	142
27	Mixing Plant (EM refers to as "Charge Building")	0.068	0.006	0.000	0.000	0.001	89%	1,919	164	4	4	33
28	Pretreatment Plant - Main Machine	0.414	0.013	0.000	0.000	0.006	20%	2,612	79	2	2	39
29	Copper Dressing Furnace	0.019	0.018	0.000	0.001	-	90%	537	518	13	32	0
30	TSL Furnace Tapping Platform	0.041	0.050	0.001	0.001	0.010	89%	1148	1409	35	35	282

Volume sources - stockpile fugitives

Includes Fugitive emissions from stored process materials as well as handling including mixing, loading, transport, unloading, etc
Objective: All materials covered. Any handling activity controlled or under cover. 10 year goal - no external storage

Source ID	Description	PM10 Dust Emission rate (g/s)	Lead Emission rate (g/s)	Arsenic Emission rate (g/s)	Cadmium Emission rate (g/s)	Zinc Emission rate (g/s)	Percent Time of Emissions	Total PM10 Dust emissions (kg)	Total lead emissions (kg)	Total Arsenic emissions (kg)	Total Cadmium emissions (kg)	Total Zinc emissions (kg)
Volume sources - stockpile fugitives - Total		917	9	0	0	50		80,128	13,158	203	77	9,962
Stockpiles - Uncovered - Total		10	1	0	0	1		45,565	6,698	82	40	6,279
26.1	PIT/Crusher area	1.010	0.136	0.003	0.001	0.183	15%	4,687	632	14	4	849
26.2	PGP stockpile	2.031	0.089	0.009	0.004	0.658	15%	9,419	414	41	18	3,052

Emissions to Air

Source ID	Description	PM10 Dust Emission rate (g/s)	Lead Emission rate (g/s)	Arsenic Emission rate (g/s)	Cadmium Emission rate (g/s)	Zinc Emission rate (g/s)	Percent Time of Emissions	Total PM10 Dust emissions (kg)	Total lead emissions (kg)	Total Arsenic emissions (kg)	Total Cadmium emissions (kg)	Total Zinc emissions (kg)
26.3	LSLC stockpile	0.677	0.278	0.001	0.002	0.075	15%	3,140	1,287	6	11	349
26.4	BuLP stockpile	0.772	0.135	0.004	0.002	0.073	15%	3,580	628	21	8	336
26.5	TSL slag blocks & residue mixes stockpiles	1.378	0.798	0.000	0.000	0.160	15%	6,392	3,700	0	0	740
26.6	Andritz Stockpile											
26.7	Blacksand stockpile - working section	3.956	0.008	0.000	0.000	0.206	15%	18,348	37	0	0	954
27	Stockpiles - Covered - Total	0	0	0	0	0		0	0	0	0	0
28	Materials Handling	454	4	0	0	25		34,563	6,460	121	37	3,682
28.1	Normal Conditions	0	0	0	0	0		3,397	2,082	21	5	718
28.1.1	Ships loading/unloading	0.075	0.049	0.001	0.000	0.014	100%	2,368	1,557	20	4	448
28.1.2	Trains loading/unloading	0.000	0.000	0.000	0.000	0.000	100%	1.6	2.3	0.0	0.0	0.2
28.1.3	Trucks loading/unloading	0.025	0.016	0.000	0.000	0.006	100%	804	520	1	1	199
28.1.4	Trucks loading/unloading - Battery Bay											
28.1.5	Grit Blasting											
28.1.6	Debagging materials from bulka bags											
28.1.7	Tippler unloading											
28.1.8	BF Feed Preparation Operations											
28.1.9	Slag Fumer Mixing Pad	0.07080	0.0007	0.0000	0.0000	0.0226	10%	223	2	0	0	71
28.1.10	EAF Plant Deliveries											
28.2	Abnormal Conditions	453.5	3.8	0.1	0.0	24.5		31,166	4378.0	100.2	32.1	2964.4
28.2.1	Ship unloading in high winds											
28.2.2	PGP stockpile, extreme winds	2.8	0.125	0.012	0.005	0.920	4.7%	4,209	185	19	8	1,364
28.2.3	LSLC stockpile, extreme winds	2.8	1.164	0.006	0.010	0.315	4.7%	4,209	1,726	8	15	467
28.2.4	BuLP stockpile, extreme winds	2.8	0.498	0.016	0.006	0.267	4.7%	4,209	739	24	9	396
28.2.5	Andritz Stockpile, extreme winds	3.1	1.147224	0.0	0.0	0.0	4.7%	4,602	1,700	49	0	13

Emissions to Air

Source ID	Description	PM10 Dust Emission rate (g/s)	Lead Emission rate (g/s)	Arsenic Emission rate (g/s)	Cadmium Emission rate (g/s)	Zinc Emission rate (g/s)	Percent Time of Emissions	Total PM10 Dust emissions (kg)	Total lead emissions (kg)	Total Arsenic emissions (kg)	Total Cadmium emissions (kg)	Total Zinc emissions (kg)
28.2.6	Blacksand stockpile - working section, extreme winds	335.8	0.672			17.461	0.1%	10,590	21	-	-	551
28.2.7	Blacksand stockpile - covered, extreme winds	106.1	0.212			5.518	0.1%	3,347	7	-	-	174
28.2.8	Ad hoc campaigns for material sales											

Volume sources - vehicle emissions

Includes all wheel generated emissions, dust from roads, leakage and dusting from materials being transported

Objective: Optimised internal material logistics to minimise material movements, best practise cleaning technology, good surface condition on all roads

36	Wheel generated emissions - General	0.338	0.141	0.003	0.001	0.054	100%	10,648	4,448	82	30	1,712
Heavy Use Roads												
36	Wheel generated emissions - Haul Roads - Total	0	0	0	0	0		0	0	0	0	0
36.1	Wheel generated emissions - Heavy Use - Unsealed Roads	0	0	0	0	0		0	0	0	0	0
36.2	Wheel generated emissions - Heavy Use - Sealed Roads	0	0	0	0	0		0	0	0	0	0
Medium Use Roads												
37	Wheel generated emissions - Medium Use Roads - Total	0	0	0	0	0		0	0	0	0	0
37.1	Wheel generated emissions - Medium Use - Unsealed Roads	0	0	0	0	0		0	0	0	0	0
37.2	Wheel generated emissions - Medium Use - Sealed Roads	0	0	0	0	0		0	0	0	0	0
Low Use Roads												
38	Wheel generated emissions - Low Use Roads - Total	0	0	0	0	0		8	0	0	0	2
38.1	Wheel generated emissions - Low Use - Unsealed Roads	0	0	0	0	0		8	0	0	0	2
38.2	Wheel generated emissions - Low Use - Sealed Roads	0	0	0	0	0		0	0	0	0	0
Total controlled emissions (kg)		3.4	0.8	0.1	0.1	0.5		92,149	21,191	1,604	1,840	12,617
Total fugitive emissions (kg)		921.3	11.4	0.2	0.1	51.4		162,479	44,150	961	873	32,270
Total emissions (kg)		924.7	12.2	0.3	0.2	51.9		254,628	65,341	2,565	2,713	44,887



ghd.com

→ **The Power of Commitment**

