

**Manual of Legal Responsibilities and
Technical Requirements for Traffic Control Devices
Part 2:**

**Code of Technical
Requirements**

March 2024



Government of South Australia
Department for Infrastructure
and Transport

**Build.
Move.
Connect.**

Disclaimer

While every reasonable effort has been made to ensure that this document is correct at the time of publication, the Minister for Infrastructure and Transport, its agencies, instrumentalities, employees and contractors disclaim any and all liability to any person in respect to anything or the consequence of anything done or omitted to be done in reliance upon the whole or any part of this document.

Publication details

Document information

Title	Code of Technical Requirements
Owner	Traffic Engineering Standards
KNet reference	2003072

Change history

Date changed	Nature of amendment
14 August 2023	Section 1.2 - Reference list updated, references to AS 2876 (now withdrawn) removed; references to AS 1742.2 updated for 2022 version; Section 2.2 - R9-18 added to signs not to be used, references to Supplement to AS 1742.10 added, Section 2.3 - R9-19 added to signs requiring separate approval; Section 2.9 - W8-SA23 added; Section 3.2 - New line types in AS 1742.2 added to pavement markings not to be used list; Requirements for Give Way lines harmonised with AS 1742.2; Section 5.3 - Variations to AS 1742.2 Sections 2.8.6, 2.9.7 and Appendix I added for modified intersection treatments; Section 6.2 - Operation of emergency services traffic signals clarified; Section 8 - Pedestrian crossing (all types) information moved to Supplement to AS 1742.10; Section 9.1 - Clarification of indented parking and minimum parking distances; Section 9.7, 9.8 - parking control signs and guidance for EV charging added; Section 10.1.1.2 - Location and siting of LATM devices updated to reflect update to AS 1742.13 (2023 version); Section 10.5, Section 10.6.3, Section 10.9 - Raised pavements, road cushions and centre blisters updated to reflect their inclusion in AS 1742.13; Section 11.2 - Guidance on Stop or Give Way signs at access driveways moved to Off-street Traffic Control section; Appendices related to pedestrian crossing treatments deleted (move to Supplement to AS 1742.10)
7 March 2024	Section 1.4.3 - Inclusion of guidance on providing detail of non-standard devices in Traffic Impact Statements; Section 2 - Sign index reference updated, reference to AS 1743 sign specifications added; Section 9.7 - Electric Vehicle parking sign guidance added

Approvals record

Approver	Position	Date	Signature
Stephen Pascale	Manager, Traffic Services	6 March 2024	Digital Approval 34538

We acknowledge the Traditional Custodians of the Country throughout South Australia and recognise their continuing connection to land and waters. We pay our respects to the diversity of cultures, significance of contributions and to Elders past, present and emerging.



Contents

1. General	5
1.1. Scope	5
1.2. Reference documents	5
1.3. Definitions	6
1.4. Legal requirements	7
1.5. Application of devices	10
1.6. Road design and traffic control devices	10
1.7. Road safety	10
1.8. Accessible facilities	12
1.9. Lighting	12
2. Signs	13
2.1. General	13
2.2. Signs not to be used	13
2.3. Signs requiring separate approval	14
2.4. Auxiliary regulatory series	16
2.5. Hazard markers	17
2.6. Sign size	17
2.7. Sign installation	17
2.8. Sign retroreflectivity and illumination	18
2.9. Sign fluorescence	19
3. Pavement markings and delineation	21
3.1. General	21
3.2. Pavement markings not to be used	21
3.3. Pavement markings requiring separate approval	21
3.4. Longitudinal lines	22
3.5. Transverse lines	22
3.6. Pavement bars	22
3.7. Pavement markings on footpaths and shared paths	22
4. Speed control	23
4.1. General	23
5. Intersection control signs	24
5.1. GIVE WAY and STOP signs	24
5.2. Requirements for installation of STOP signs	24
5.3. Modified intersection treatments (AS 1742.2 Section 2.8.6, Section 2.9.7 and Appendix I)	24
6. Traffic signals	26
6.1. Intersection signals	26
6.2. Emergency services traffic signals	28
6.3. Flashing yellow traffic lights	29
7. Roundabouts	30
7.1. General	30
7.2. Construction	31
7.3. Roundabouts on bus routes	31
8. Pedestrian crossings	32
8.1. General	32
9. Parking	33
9.1. General	33
9.2. Parking control signs requiring separate approval	34

9.3.	Drop off and pick up zones	34
9.4.	Angle parking	34
9.5.	Centre-of-road parking	35
9.6.	Temporary parking	35
9.7.	Electric vehicle parking.....	35
9.8.	Electric vehicle charging infrastructure on roads	37
10.	Local Area Traffic Management.....	38
10.1.	General	38
10.2.	Perimeter thresholds	40
10.3.	Contrasting pavements	41
10.4.	Road murals.....	43
10.5.	Raised pavements.....	45
10.6.	Road humps.....	49
10.7.	Road closures	54
10.8.	Slow points.....	56
10.9.	Centre blister.....	59
10.10.	Driveway entries and links.....	63
10.11.	T-intersection re-arrangement	73
11.	Off-street traffic control.....	76
11.1.	General	76
11.2.	Stop and Give Way signs at access driveways.....	76
12.	Traffic control at works on roads	77
12.1.	General	77
12.2.	Speed limits at works on roads.....	77
	Appendix A: Traffic control devices requiring separate approval	78
	Appendix B: Emergency services traffic signal details	81
	Appendix C: Local Street Roundabouts	82
	Appendix D: Standard Design Envelope	88

1. General

1.1. Scope

This *Code of Technical Requirements* ('the Code') sets out the mandatory requirements for the variations from the Australian Standards and Austroads Guides for the use of traffic control devices in South Australia. It forms Part 2 of the *Manual of Legal Responsibilities and Technical Requirements for Traffic Control Devices* ('the Manual'). The Manual also contains *Part 1: Legal Responsibilities* ('the Instruments').

Traffic control devices shall be used only in accordance with this Code, the Australian Standards, Austroads Guides and the reference documents listed below. Where the Code varies from, or provides additional information to that contained in the Australian Standards and Austroads Guides, the Code shall take precedence.

The Code amends some aspects of the Australian Standards and Austroads Guides where South Australia's practices differ. This Code specifies:

- selected values when a range is specified in Australian Standards;
- signs and devices which shall not be used in South Australia;
- signs and devices not covered in Australian Standards; and
- other variations from the Australian Standards and Austroads Guides.

The Code applies to all roads and road-related areas under the [Road Traffic Act 1961](http://www.legislation.sa.gov.au/LZ/C/A/ROAD%20TRAFFIC%20ACT%201961.aspx) ('the Act') (<http://www.legislation.sa.gov.au/LZ/C/A/ROAD%20TRAFFIC%20ACT%201961.aspx>).

1.2. Reference documents

The following documents contain information on or related to traffic control devices, or the design, construction and specification of materials or structures used in conjunction with traffic control devices. Where these documents specify requirements for traffic control devices, they shall be complied with in conjunction with this Code:

Australian Standards:

AS/NZS 1158	<i>Lighting for roads and public spaces</i>
AS 1428	<i>Design for Access and Mobility</i>
AS 1742	<i>Manual of uniform traffic control devices (MUTCD)</i>
AS 1743	<i>Road signs - Specifications</i>
AS 1744	<i>Forms of letters and numerals for road signs</i>
AS/NZS 1906	<i>Retroreflective materials and devices for road traffic control purposes</i>
AS/NZS 1906.1	<i>Retroreflective sheeting</i>
AS/NZS 1906.2	<i>Retroreflective devices (non-pavement)</i>
AS 2144	<i>Traffic signal lanterns</i>
AS 2353	<i>Pedestrian push-button assemblies</i>
AS/NZS 2890.1	<i>Parking facilities - Off-street car parking</i>
AS/NZS 2890.5	<i>Parking facilities - On-street car parking</i>
AS/NZS 2890.6	<i>Parking facilities - Off-street parking for people with disabilities</i>
AS/NZS 3845	<i>Road safety barrier systems</i>
AS 4049 series	<i>Paint and related materials – Pavement marking materials</i>

AS 5156 *Electronic speed limit signs*

Austrroads Guides:

Austrroads Guide to Traffic Management Series

Austrroads Guide to Road Design Series (see Note)

Austrroads Guide to Road Safety Series

DIT documents:

SA Standards for Workzone Traffic Management

Speed Limit Guideline for South Australia

Operational Instructions

Australian Standards Supplements and Austrroads Supplements

Pavement Marking Manual

Standard Road Signs Specifications

Guidelines for Events on SA Roads

Road Sign Guidelines – Guide to visitor and services road signs in South Australia

The DIT documents can be accessed in the Publications section on the [Technical Standards and Guidelines – Road and Traffic Management](http://www.dit.sa.gov.au/standards/tass) web page (<http://www.dit.sa.gov.au/standards/tass>).

For traffic control devices on roads under the care, control and management of the Commissioner of Highways, reference shall also be made to the [DIT Master Specification](http://www.dit.sa.gov.au/contractor_documents/masterspecifications) (http://www.dit.sa.gov.au/contractor_documents/masterspecifications).

NOTE: The *Austrroads Guide to Road Design Part 7: New and Emerging Treatments (2020)* contains innovative treatments which are yet to be included in other parts of the Guides. These treatments are considered to be non-standard and shall only be used on a trial basis subject to consultation with DIT and the appropriate approvals for traffic control devices under the *Road Traffic Act 1961* (see [Section 1.4.2](#)).

1.3. Definitions

For the purpose of this Code, the following definitions apply:

Arterial road: A road that predominantly carries through traffic from one region to another, forming principal avenues of travel for traffic movements.

Council: A municipal or district council

Local street: A road or street primarily used for access to abutting properties.

May: indicates an option.

Minister: The Minister responsible for the Road Traffic Act

Non-standard: A device which is not specifically included in the Australian Standards, Austrroads guides or this Code, or any variation of a device or its use from its specification in these documents.

Off-street: Any area off the general road network commonly used by the driving public or to which the driving public are permitted to have access, for example shopping centres, caravan parks, schools, National parks.

Road authority: An authority, person or body that is responsible for the care, control or management of a road; or

Any person or body prescribed by the regulations for the purposes of this definition, in relation to specified roads or specified classes of roads.

Shall: indicates a mandatory requirement.

Should: indicates a recommendation.

Standard Design Envelope (SDE): A design tool consisting of two concentric arcs with an outer radius of 36 m and an inner radius of 34 m, used for local street roundabout, angled slow point and centre blister design.

Traffic Control Device: A sign, signal, marking, structure or other device or thing, to direct or warn traffic on, entering or leaving a road, and includes -

- (a) a traffic cone, barrier, structure or other device or thing to wholly or partially close a road or part of a road; and
- (b) a parking ticket-vending machine and parking meter.

In accordance with Section 6A of the Act, road includes road-related area.

1.4. Legal requirements

Traffic control devices shall be installed, maintained, altered, operated and removed with the proper approval. Without this approval the person may be guilty of an offence under section 21 of the [Road Traffic Act 1961](#) ('the Act')

(<http://www.legislation.sa.gov.au/LZ/C/A/ROAD%20TRAFFIC%20ACT%201961.aspx>), which carries a maximum penalty of \$5 000 or imprisonment for one year.

Under section 17 (1) and (2) of the Act, a road authority requires approval from the Minister to install, maintain, alter, operate or remove a traffic control device on, above or near a road.

Under section 17 (3) of the Act, any authority, body or person requires approval from the Minister to install, display, alter, operate or remove traffic control devices in relation to works on road, temporary road closures, or for any temporary purposes.

1.4.1. Ministerial delegation

The Minister has delegated powers and granted approvals by issuing Instruments to the following road authorities:

- Commissioner of Highways,
- Commissioner of Police,
- [Councils](#), (<http://www.dit.sa.gov.au/?a=114810>)
- Adelaide Airport Limited,

- Railway owners accredited under the *Rail Safety Act 2007* ([South Australian Government Gazette No. 7 Thursday 24 January 2013, page 123](#)), and
- Board of the Botanic Gardens and Herbarium.

Where a road authority has not been issued an Instrument, they should approach Council in the first instance. The Minister has delegated to Council the power to specifically approve some traffic control devices for other road authorities as defined by the *Road Traffic Act 1961*. Other road authorities may include those responsible for:

- car parks,
- universities,
- national parks, or
- community titles.

The Commissioner of Highways' delegation includes un-incorporated areas.

The Commissioner of Highways has authorised some positions in DIT to undertake various functions or powers delegated from the Minister, subject to conditions. Details are contained in their specific written Instrument.

In another Instrument, the Commissioner has granted persons other than road authorities [approval to temporarily install, maintain, alter, operate, display or remove traffic control devices](#) (<http://www.dit.sa.gov.au/?a=101171>).

All Instruments are contained in *Part 1: Legal Responsibilities* ('the Instruments') of the *Manual of Legal Responsibilities and Technical Requirements for Traffic Control Devices*.

These Instruments specify the conditions of approval or authorisation, and the devices requiring separate approval. These approvals, authorisations and devices may vary for each Instrument. Therefore it is important for all parties to refer to their relevant Instrument to ensure they are complying within their legal authority.

One of the conditions of approval or authorisation is that all traffic control devices shall conform to the requirements of the Act, associated Rules and Regulations, and the Code.

Not complying with the details and conditions specified in the Instrument may mean the traffic control device is installed without proper authority, which is an offence under section 21 of the Act.

1.4.2. Approval process

The process to install, maintain, alter, operate, display or remove a traffic control device is contained in the Instrument issued from the Minister or the Commissioner of Highways to each authority. This process may vary depending on the function and type of device. Complying with all the conditions stated in the relevant section of the Instrument fulfils the authority's obligation and completes the process.

If the conditions in the Instrument cannot be met then the authority needs separate approval. The Commissioner of Highways will consider such requests. An application to the Commissioner of Highways shall include plans, supporting documentation and a traffic impact statement.

The traffic control devices requiring separate approval of the Commissioner of Highways or authorised delegate are listed in [Appendix A](#).

1.4.3. Traffic Impact Statement

A Traffic Impact Statement (TIS) shall be undertaken in accordance with the requirements of the relevant Instrument. Traffic control devices replaced or reinstated through general maintenance activities may be excluded from this requirement.

A TIS is a report indicating the traffic management and road safety effects for all road users, including cyclists and pedestrians, expected by the installation, operation, alteration or removal of a traffic control device. Almost all traffic control devices have an impact on road users and the way the road and the surrounding area can be used. A TIS explains both the positive and negative effects expected on all road users by implementing the proposed devices.

A TIS is a source of information from which there should be a clear understanding of the proposal, the need for the proposal, the alternatives considered, any impacts that may occur and any measures to be taken to minimise those impacts.

A TIS provides a framework within which informed decision-makers may consider the traffic management aspects of the proposal in parallel with social, economic, technical and other factors.

All relevant details of the proposal shall be provided in the TIS. These include:

- background information detailing the intent of the proposed changes, and reasons for the installation, alteration or removal of the traffic control device;
- the impacts and the likely effects of the traffic control device in the immediate vicinity of the device and where necessary, the wider area or road network;
- identification and discussion of all the advantages and disadvantages;
- the options considered and the reasoning behind the selection of the proposed device, and rejection of other devices;
- details of traffic re-distribution and generation;
- identification of the risks associated with the proposal and an assessment of these risks;
- expected time frame for the implementation of the proposed changes to traffic control devices, including any staging and timing details.

A TIS must clearly identify whether the traffic control device and its use complies with the *Code of Technical Requirements* and the *Australian Standards*. Where a traffic control device or treatment does not conform with the *Code of Technical Requirements* and the *Australian Standards*, it is non-standard and the TIS must include a detailed assessment of the treatment or device, including how the device relates to the applicable road rules.

When preparing a TIS every effort should be made to use plain English. Technical terms should be kept to a minimum as the TIS could be read by non-technical persons. The TIS need not be a lengthy document and will depend on the complexity of the proposal.

The TIS template (<http://www.dit.sa.gov.au/?a=43141>) should be used to assist in the preparation of a TIS. This template includes the certification and endorsement statements which reflect the requirements of the Instrument to Council.

1.4.4. Recordkeeping

The road authority shall keep records of the times and dates that traffic control devices are installed, altered or removed. The road authority shall also retain records of any approval documentation associated with traffic control devices.

1.5. Application of devices

Signs and other traffic control devices lose their effectiveness if used unnecessarily or too frequently. Their use shall be restricted to the minimum required to aid the safe and orderly movement of road users. Application of this Code ensures the consistent use of traffic control devices across the state.

1.6. Road design and traffic control devices

Many traffic management treatments comprise a combination of geometric road design and traffic control devices.

The geometric design decisions are the responsibility of the designer and the relevant road authority and do not require separate approval from the Commissioner of Highways or authorised delegate. The designer must use sound, professional judgement in developing the design and take into account the available guidance, such as the documents listed in [Section 1.2](#), to assist in making those judgements. Decisions regarding the use of geometric design values outside of the Normal Design Domain, and the use of Extended Design Domain values is the responsibility of the relevant road authority.

The traffic control devices shall be used only in accordance with this Code, the Australian Standards, Austroads Guides, and the reference documents in [Section 1.2](#), and comply with the approval process listed in [Section 1.4.2](#). Variations from the mandatory or 'shall' requirements for traffic control devices in these documents are considered to be non-standard and will require the approval of the Commissioner of Highways or authorised delegate. A variation from a 'should' requirement or a recommendation in these documents is not considered to be non-standard. Any 'should' requirements are recommendations which reflect the safe, consistent and recognised practices however variations are permitted where necessary. Any such variations need to be highlighted and addressed in the Traffic Impact Statement.

NOTE: The Austroads *Guide to Road Design Part 7: New and Emerging Treatments* (2020) contains innovative treatments which are yet to be included in other parts of the Guides. These treatments are considered to be non-standard and shall only be used on a trial basis subject to consultation with DIT and the appropriate approvals for traffic control devices under the *Road Traffic Act 1961* (see [Section 1.4.2](#)).

1.7. Road safety

Traffic control devices should assist in the creation of a safer road environment. The incorrect or inappropriate installation of any traffic control device has the potential to create a hazard to road users due to:

- misuse of the device;
- incorrect installation;
- inappropriate location of the device;
- physical changes to the road environment;
- driver's perception; or
- legal implications under the [Road Traffic Act 1961](#)
(<http://www.legislation.sa.gov.au/LZ/C/A/ROAD%20TRAFFIC%20ACT%201961.aspx>)

It is important to select the most appropriate traffic control device(s) with consideration given to the likely impacts on all road users. Failure to do so may create potentially hazardous situations.

The preparation of a Traffic Impact Statement (refer to [Section 1.4.3](#)) should help to identify and address any potential safety implications of the proposed device.

The use of traffic control devices should incorporate the safe system approach to road safety. The safe system approach acknowledges that human error is inevitable, and that when errors occur, the risk of serious injury or death should be minimised. Applying the safe system approach should assist in the creation of a forgiving road environment which takes into account human error and the physical tolerances of humans, allowing road users to survive and avoid serious injury in the event of a crash. In a safe system, roads should be designed to reduce the incidence and severity of crashes through measures such as the provision of clear driver guidance, a forgiving roadside and management of speeds.

1.7.1. Road Safety Audits

A Road Safety Audit may be conducted to formally examine the crash potential and safety performance of a proposed traffic control device installation. A Road Safety Audit is a formal, defined process, conducted by an independent, qualified team with the appropriate experience and training.

A Road Safety Audit examines whether the road or treatment is fit for purpose and will perform safely for road users. It is not just a check for compliance with standards. A Road Safety Audit incorporates the safe system approach in ensuring that road elements which may contribute to crash occurrence or severity are identified and removed or treated.

It is up to individual road authorities to determine their own program of road safety audits. This should not necessarily be based on the scale of the project, rather the scale of the potential hazards which may be identified during the process. Projects should be audited earlier rather than later to enable the early elimination of potential safety problems. *Austrroads Guide to Road Safety Part 6: Managing Road Safety Audits* and *Part 6A: Implementing Road Safety Audits* provides further guidance on the Road Safety Audit process. A register of senior road safety auditors in South Australia is available on the [DIT Contracts & Tenders – Prequalification](#) page under the *Prequalification of Road Safety / Safe Systems Assessment Auditors and Restricted Access Vehicle Route Assessors* heading (http://www.dit.sa.gov.au/contractor_documents/prequalification).

1.7.2. Vegetation and other roadside hazards

The installation of traffic control devices may sometimes form part of an overall traffic management treatment which also involves the use of landscaping and installation of roadside furniture. Landscaping and roadside furniture, including objects located on or near road-related areas such as rest areas, bicycle paths or car parks, shall not cause an unreasonable degree of hazard if struck by a vehicle.

Landscaping, vegetation, structures or other objects shall not:

- (a) Diminish the sight distance to such an extent as to be a hazard, or
- (b) Be placed in a position which would present an unreasonable degree of hazard if struck by an errant vehicle. This includes such items as:
 - (i) non-frangible trees and shrubs, ie trees greater than 100 mm in diameter at the base;
 - (ii) any structure, including fences that use horizontal rails with the potential to cause spearing type injuries; or

(iii) boulders, walls, monuments, or other substantial structures or objects.

Material such as loose gravel, stones or pebbles, bark, wood chips or sand shall not be placed where it would spill or be washed onto the road or footpath and create a hazard to road users, such as by producing slippery conditions or by obscuring pavement or kerb markings.

Austrroads *Guide to Road Safety series* provides further details on the provision of a safe road environment.

1.7.3. Integrity of devices

Devices shall be constructed with adequate strength and durability to withstand all conditions of installation and operation which may be reasonably expected. Devices used on a temporary or trial basis shall be constructed to the same standard as permanent installations.

Kerbs may be manufactured from products other than concrete. The kerb shall be securely fastened to the road pavement so that it is not easily dislodged.

Sand bags shall not be used.

1.8. Accessible facilities

Traffic management treatments involving facilities for pedestrians shall incorporate the provision of accessible facilities for people with mobility or vision impairments.

The Commonwealth [Disability Discrimination Act 1992](http://www.comlaw.gov.au/Current/C2023C00355) (<http://www.comlaw.gov.au/Current/C2023C00355>) provides protection for everyone in Australia against discrimination based on disability. Disability discrimination happens when people with a disability are treated less fairly than people without a disability. A person with a disability has a right to access public places in the same way as a person without a disability. Denying or limiting access to public places by people with mobility or vision impairments is against the law.

Providing accessible facilities includes, but is not limited to, measures such as kerb ramps and cut-outs, holding rails, tactile ground surface indicators and audio tactile push buttons. The reference documents listed in [Section 1.2](#) provide further details on catering for people with mobility or vision impairments within the pedestrian environment.

1.9. Lighting

Where lighting is provided in accordance with the requirements of *AS/NZS 1158 Lighting for roads and public spaces*, it shall be provided before the installation of the traffic control device.

2. Signs

2.1. General

Signs shall only be installed in accordance with AS 1742 (various parts) and the variations and additions contained in DIT's *Operational Instructions and Supplements*, and this *Code of Technical Requirements*.

Signs shall only be installed with approval of the appropriate authority as detailed in the Code (refer to [Section 1.4](#)) and the relevant Instrument (refer to *Part 1: Legal Responsibilities* ('the Instruments') of the *Manual of Legal Responsibilities and Technical Requirements for Traffic Control Devices*). Where the DIT *Sign Index* indicates that a sign requires the approval of the Manager, Traffic Services, the sign shall only be used once specific approval from the Commissioner of Highways or authorised delegate has been granted.

Sign specification details of signs for use in South Australia are provided in the [DIT Sign Index](#) (<https://signindex.dit.sa.gov.au>) and the Australian Standard AS 1743 *Road Signs - Specifications*. The *DIT Sign Index* provides the sign specification details of signs which are not included in the Australian Standards but have been developed for use in South Australia. For all other sign specification details, refer to AS 1743. Signs in AS 1743 which **shall not** be used in South Australia are listed in [Section 2.2](#).

Authorities shall not vary or develop signs for their own particular use. Where no suitable sign exists, a new sign may be developed by contacting DIT's Traffic Engineering Standards (email DIT.TASSAdminSupport@sa.gov.au).

2.2. Signs not to be used

Unless included in the DIT *Sign Index* or AS 1743, the signs shown in Schedule 3 of the [Australian Road Rules](#) (<http://www.legislation.sa.gov.au/LZ/C/R/Australian%20Road%20Rules.aspx>) shall not be used.

The signs listed in this section, although contained in AS 1742 *Manual of uniform traffic control devices*, shall not be installed on or near a road in South Australia.

Where an alternative sign is permitted in the list below, that sign shall be used instead.

Signs which shall not be used		Permitted sign with relevant Instrument
Regulatory signs		
R2-10	Give Way to pedestrians	R2-SA102 (Left or Right) Turn Give Way to Pedestrians & Cyclists (see Section 6.1.4)
R3-4	Children Crossing 40 when lights flashing	R3-SA56 Koala Pedestrian Crossing Speed Limit when lights flashing (refer to DIT's <i>Supplement to AS 1742.10</i>)

Signs which shall not be used		Permitted sign with relevant Instrument	
R4-8	School Zone	R3-SA58	School Zone Speed Limit when children present (refer to DIT's <i>Speed Limit Guideline for South Australia</i>)
R4-9	End School Zone	R3-SA59	End School Zone (refer to DIT's <i>Speed Limit Guideline for South Australia</i>)
R5-39	Tow-away	N/A	
R9-18	To Traffic From Left	See Section 5.3	for alternative treatments
Warning signs			
W1-8-x	Tilting truck with advisory speed series	W1-SA50	Truck Tilting with Curve series
Temporary signs			
T1-19	Stock Ahead (symbolic)	TES 6396	Stock on Road

2.3. Signs requiring separate approval

The following signs may only be used with separate approval from the Commissioner of Highways or authorised delegate:

Regulatory Signs

R2-15	U-turn permitted
R2-20	Left turn on red permitted after stopping
R2-21	Right turn from left only
R2-22	No hook turn by bicycles
R2-SA61	Right turn from left lane only Adelaide Metro Buses
R2-SA62	Right turn from left lane only Adelaide Metro Buses with times
R3-2	Safety zone
R3-5	Pedestrians may cross diagonally
R4 series	Speed limit signs except: <ul style="list-style-type: none"> at works on roads (see Section 12.2) School zones (refer <i>Speed Limit Guideline for South Australia</i>) Wombat crossings (refer <i>Supplement to AS 1742.10</i>) Koala crossings (refer <i>Supplement to AS 1742.10</i>)
R5-50	Clearway (start)
R5-51	End clearway
R5-58	Emergency stopping lane
R6-13	No pedestrians beyond this point
R6-18	Buses must enter
R6-19	Start freeway

R6-20	Freeway entrance
R6-21	End freeway
R6-22	Trucks and buses must use low gear
R6-23	End truck and bus low gear area
R6-27	Trucks must enter
R6-28	Trucks use left lane
R6-29	Keep left unless overtaking
R6-30	Median turning lane
R6-32	End keep left unless overtaking
R6-SA103	End no wheeled recreational devices (Skaters permitted)
R6-SA104	No wheeled recreational devices (All skaters prohibited)
R7-1-1	Bus Lane
R7-1-3	Truck Lane
R7-1-5	Tram Lane
R7-1-6	Bus, bicycle lane
R7-7 series	Transit lane signs
R7-9 series	End transit lane signs
R7-8	Bus only
R7-10	Tram only
R9-19	Give way if going straight ahead
R9-SA106	over xx.x t
R9-SA107	On green arrow

Guide Signs

G9-10	Slow vehicle lane ahead
G9-11	Slow vehicle lane 1km ahead
G9-12	Slow vehicles use left lane
G9-17	Winding road ends x km
G9-46	Very steep climb not suitable for ...
G9-47	Very steep climb next x kms
G9-67-2AA	Keep Tracks Clear (small size)
G9-79	Speed limit ahead
GE9-22-1	Lane ends merge right
GE6-9	End freeway
GE6-10	End freeway 1 km
GE9-3	Reduce speed now
GE6-2	Prohibited on freeway, pedestrians etc
GE2-3	Exit

Signs for temporary purposes

R6-8 / T7-1	Stop / Slow Bat when used for the purpose of an event under Clause E of the <i>Instrument of General Approval to Council</i> . Stop / Slow Bat operators must carry evidence certifying current accreditation in the appropriate DIT approved Temporary Traffic Management training qualification, in the form of a Workzone Traffic Management card issued by DIT.
-------------	---

Other signs

Any signs listed as requiring approval of the Manager, Traffic Services on the DIT Sign Index

2.4. Auxiliary regulatory series

2.4.1. Exception plates

The following signs, in addition to those contained in *AS 1742.2 MUTCD Part 2: Traffic control devices for general use (2022)* Section 2.8.6(b), shall be used with regulatory signs where those classes of vehicle are to be exempted from the control. The signs shall be mounted below the regulatory sign and match it in width.

R9-SA50	Police Vehicles Excepted
R9-SA51	Ambulance Excepted
R9-SA52	High Vehicles Excepted
R9-SA54	Emergency and Maintenance Vehicles Excepted
R9-SA101	Busway Buses Excepted
R9-SA102	Emergency Vehicles Excepted
R9-SA103	Fuel Tankers Excepted
R9-SA104	Trams Excepted
R9-SA105	Local Delivery or Pickup Excepted
R9-SA108	Bus Lane Vehicles Excepted
R9-SA111	Garbage Trucks Excepted

The specific details of these signs are contained in the [DIT Sign Index \(https://signindex.dit.sa.gov.au\)](https://signindex.dit.sa.gov.au).

Refer to Regulation 9 of the Road Traffic (Road Rules – Ancillary and Miscellaneous Provisions) Regulations 2014 for provisions relating to a “Maintenance Vehicles Excepted” sign displayed with a no U-turn sign.

2.4.2. Location plates

The following signs shall be used in conjunction with signs R2-5, R2-6, R2-7, and R2-9 where it is necessary to advise drivers of the road to which the sign applies. The sign shall be mounted below the regulatory signs specified above and match it in width.

R9-SA53-1	AT (two line name of road)
R9-SA53-2	AT (three line name of road)
R9-SA55-1	TO (two line name of road)
R9-SA55-2	TO (three line name of road)

If used, the ‘AT’ sign shall be placed in advance of the intersection, and the ‘TO’ sign shall be placed at the intersection.

The specific details of these signs are contained in the [DIT Sign Index \(https://signindex.dit.sa.gov.au\)](https://signindex.dit.sa.gov.au).

2.4.3. Times of operation module

The term ‘school days’ may only be used on the times of operation module (R9-SA57) to indicate a part time bicycle lane on roads other than those under the care, control and management of the Commissioner of Highways. The use of ‘Mon – Fri’ is preferred, and the term ‘school days’ should

generally be avoided and limited to situations where weekday operation would cause unacceptable restrictions to parking.

'School days' shall only be used where a bicycle facility specifically caters for school traffic, and there is no demand for a bicycle facility at other times.

State school term dates are published on the [South Australian Department for Education web page](http://www.education.sa.gov.au/) (<http://www.education.sa.gov.au/>). Where a bicycle facility is intended to specifically cater for private school traffic, variations from the published term dates may contribute to confusion about times of operation, particularly as the bicycle facility may be remote from the school and it may not be obvious to drivers whether the school is open.

2.5. Hazard markers

The provision of *AS 1742.2 MUTCD Part 2: Traffic control devices for general use (2022)* section 2.12.2 to allow variations to the size of boards or the number and spacing of bands or chevrons is not permitted in South Australia. Hazard markers shall be in accordance with those included on the DIT Sign Index. Two D4-SA1-1 Unidirectional Hazard Markers may be used to form an extended bi-directional marker.

2.6. Sign size

The size of the following signs may be reduced from an A size as stated in *AS 1742* to AA size (previously S size in South Australia) and used only where raised traffic islands or medians are too narrow to accommodate the A size sign:

R2-3L	KEEP LEFT
R2-5	No U-Turn
R2-6R	No Right Turn
R2-9	Right Lane Must Turn Right sign
R9-1-1	Time plate (one time)
R9-1-2	Time plate (two times)

The R2-SA3 KEEP LEFT (vertical) shall only be used where back-to-back median is installed or at sites where R2-3 signs are frequently struck by vehicles.

The [DIT Sign Index](https://signindex.dit.sa.gov.au) (<https://signindex.dit.sa.gov.au>) contains details of specific sign dimensions.

2.7. Sign installation

Only one sign shall be installed on each post facing a particular direction, except where one sign supplements the other, or where route, directional or parking signs are grouped. A supplementary sign shall be placed below the main sign.



Figure 2.1 Good sign installation practice (no overlap)



Figure 2.2 Poor sign installation practice (signs overlap)



Figure 2.3 Poor installation practice (signs overlap, incorrect use and installation)

There shall be no overlap between any sign mounted on the same post.

It is acceptable to mount signs on existing utility service poles provided this will not detract from the proper function of the sign and the owner has given permission.

2.7.1. Duplicated signs

Where a warning sign is installed on both sides of the carriageway, and the symbol shown on the warning sign shows some form of direction, the sign shall be manufactured and installed so that the symbol is facing towards the road or carriageway, as shown in Figure 2.4.



Figure 2.4 Duplicated pedestrian warning signs

2.8. Sign retroreflectivity and illumination

Retroreflective material used on signs shall meet at least the requirement for Class 1 sheeting as specified in *AS/NZS 1906.1 Retroreflective materials*.

Bicycle / Pedestrian Series (R8) and Parking Series (R5) signs shall be non-reflective legend and background, except:

- R5-50 Clearway
- R5-51 End Clearway

R5-58 Emergency Stopping Lane Only

For electronic presentation of signs, refer to *AS 1742.1 MUTCD Part 1: General introduction and index of signs (2021)* clause 1.6.6.2 and *AS 1742.2 MUTCD Part 2: Traffic control devices for general use (2022)* clause 1.7.2.7.

2.9. Sign fluorescence

Fluorescent yellow green retroreflective material shall be used for the following pedestrian related warning signs and associated supplementary plates:

R3-1	Pedestrian Crossing
W3-3-2	Signals Ahead (midblock PACs)
W3-SA2	Give Way Sign Ahead (Left, Right or Straight)
W6-1	Pedestrians
W6-2	Pedestrian crossing ahead
W6-3	Children
W6-SA106	School Zone
W6-SA110	Pedestrian and bicycle
W8-13	Playground
W8-14	School
W8-18	Aged
W8-19	Blind
W8-20	Disabled
W8-22	Crossing ahead
W8-24	Preschool
W8-25	Refuge island
W8-SA3	On side road
W8-SA5	Distance m
W8-SA23	Crossing arrows
W8-SA56	School bus
T1-25-3M	On side road
T1-25-4M	On side road (square)
T1-28-3M	Next 1, 2, 5, 10 km
T1-28-4M	Next 1, 2, 5, 10 km (square)
T1-SA67-1M	Event Ahead
T1-SA67-2M	Event Ahead (square)
T1-SA67	Event Ahead
T2-SA104-1M	End event
T2-SA104-2M	End event (square)
T1-SA104	End event
T2-SA105-1M	Event in progress
T2-SA105-2M	Event in progress (square)
T2-SA107M(L)	Event turn left
T2-SA107M(R)	Event turn right
T2-SA108M	Event parking
T1-SA109B-1M	Speed limit changed
T1-SA125M	Event on side road



Figure 2.5 Fluorescent yellow green

OFFICIAL

T1-SA126M	Event pedestrian
T1-SA127M	Event bike
T1-SA128M	Event runner
T1-SA133M	Community event ahead

The fluorescent yellow green colour shall not be used for any other sign. Some sign specifications may still stipulate yellow for the above signs; however these signs shall be retroreflective fluorescent yellow green in South Australia.

3. Pavement markings and delineation

3.1. General

Subject to this Code, all pavement markings shall conform to the design, installation and justification requirements in the current [DIT Pavement Marking Manual](http://www.dit.sa.gov.au/?a=40257) (<http://www.dit.sa.gov.au/?a=40257>).

3.2. Pavement markings not to be used

The following markings, although contained in *AS 1742 Manual of uniform traffic control devices* or used previously in South Australia, are not to be installed on or near a road in South Australia:

- (a) Single broken dividing line (special purpose) DL3 11 m line, 1 m gap (*AS 1742.2 MUTCD Part 2: Traffic control devices for general use (2022)* figure 5.1 and clause 5.3.2.2).
- (b) Edge line EL2 200 mm wide (*AS 1742.2 MUTCD Part 2: Traffic control devices for general use (2022)* figure 5.2).
- (c) Continuity line type CL3 (*AS 1742.2 MUTCD Part 2: Traffic control devices for general use (2022)* figure 5.2 and clause 5.5.4(b)).
- (d) Continuity line type CL2 (*AS 1742.2 MUTCD Part 2: Traffic control devices for general use (2022)* figure 5.2).
- (e) Outline marking type OL2 (*AS 1742.2 MUTCD Part 2: Traffic control devices for general use (2022)* figure 5.2).
- (f) A Give-way line to indicate the safe position for a vehicle to be held at a slip lane (*AS 1742.2 MUTCD Part 2: Traffic control devices for general use (2022)* clause 5.5.2). A Give-way line at a slip lane may only be used in accordance with section 3.3.18.3 'For left turns at un-signalised intersections' of the [DIT Pavement Marking Manual](#).
- (g) Sequential turn arrows (*AS 1742.2 MUTCD Part 2: Traffic control devices for general use (2022)* section 5.7.2 and figure 5.31).
- (h) Any speed limit marking on the pavement.

The pedestrian crossing markings contained in *AS/NZS 2890.1 Parking facilities Part 1: Off-street car parking* (2004) section 4.4.2 shall not be used. Pedestrian crossings in off-street areas shall conform to Section 8.8 and the [DIT Pavement Marking Manual](#).

Lane change (merge) arrows (*AS 1742.2 MUTCD Part 2: Traffic control devices for general use (2022)* section 5.7.3) shall only be used at termination of overtaking lanes and high speed multilane roads.

3.3. Pavement markings requiring separate approval

The following markings may only be used with separate approval from the Commissioner of Highways or authorised delegate:

- (a) Bus lane markings.
- (b) All skaters prohibited (No wheeled recreational devices).
- (c) Wide dividing line treatment

3.4. Longitudinal lines

On undivided multilane roads in the urban environment, a dividing line shall be provided as either:

- (a) A 200 mm wide single barrier line (referred to as an enhanced single barrier line in the [DIT Pavement Marking Manual](#)), or
- (b) A 200 mm wide single broken dividing line (referred to as an enhanced broken (multi-lane) dividing line in the [DIT Pavement Marking Manual](#)).

3.5. Transverse lines

Give-way lines and Stop lines on roads with a speed limit of 70 km/h or less shall be 450 mm wide. Where the speed limit is 80 km/h or more, Give-way lines and Stop lines shall be 600 mm wide.

Give-way lines and Stop lines shall be located in accordance with *AS 1742.2 MUTCD Part 2: Traffic control devices for general use (2022)* clauses 5.5.2, 5.5.3 and 5.5.4. South Australian examples are shown in the [DIT Pavement Marking Manual](#).

3.6. Pavement bars

Pavement bars may be used on substandard curves on roads with a speed limit of 50 km/h or less.

3.7. Pavement markings on footpaths and shared paths

Pavement markings on footpaths and shared paths shall conform to *AS 1742.9 MUTCD Part 9: Bicycle facilities* and the [DIT Pavement Marking Manual](#). Pavement markings with an educational, advisory or promotional message intended to enhance users' awareness of the road rules or path safety are not considered to be traffic control devices and may be used. Where used, these markings shall be skid and slip resistant to the requirements of *AS 4049 Paint and related materials – Pavement marking materials* and the [DIT Pavement Marking Manual](#) so as not to cause a hazard for path users.

4. Speed control

4.1. General

Speed limits shall comply with DIT's [Speed Limit Guideline for South Australia](http://www.dit.sa.gov.au/?a=338713) (<http://www.dit.sa.gov.au/?a=338713>).

Speed limit signs may only be used with separate approval from the Commissioner of Highways or authorised delegate (except for speed limits associated with school zones, koala crossings, wombat crossings and works on roads).

5. Intersection control signs

5.1. GIVE WAY and STOP signs

GIVE WAY and STOP signs shall conform to the design, installation and justification requirements specified in *AS 1742.2 MUTCD Part 2: Traffic control devices for general use* except that:

- (a) GIVE WAY or STOP signs shall not be installed on adjacent approaches of a four-way intersection.
- (b) Pavement markings used with GIVE WAY and STOP signs shall comply with [Section 3](#).
- (c) GIVE WAY and STOP signs shall not be installed on slip lanes and expressway type entrances.

5.2. Requirements for installation of STOP signs

In addition to the requirements specified in *AS 1742.2 MUTCD Part 2: Traffic control devices for general use*, a STOP sign may be installed when the road to be controlled meets the other road at an angle of 40 degrees or less.

5.3. Modified intersection treatments (AS 1742.2 Section 2.8.6, Section 2.9.7 and Appendix I)

The treatments shown in *AS 1742.2* Figure I.1(a) *Crossroad* and Figure I.1(c) *T-intersection interim treatment where raised island is not possible* shall not be used in South Australia. The TO TRAFFIC FROM LEFT (R9-18) sign shall not be used in South Australia.

For the cross road situation, Section 5.1(a) of the Code does not allow the use of GIVE WAY signs on adjacent legs of a cross road as it may cause driver confusion. Realignment of the intersection, closure of a minor road, or retaining conventional cross road intersection control are the preferred treatment options.

The treatment shown in Figure 5.1 below may be considered as an alternative to the treatment shown in Figure I.1(c). The GIVE WAY (R1-2) / TO TRAFFIC FROM LEFT (R9-18) sign combination and associated Give Way line across the predominant traffic flow may cause additional confusion to drivers and shall not be used. A short section of Give Way line (see Figure 5.1) may be marked within the length of continuous dividing line to highlight the Give Way requirement for traffic turning right from the predominant traffic flow.

Use of the GIVE WAY IF GOING STRAIGHT AHEAD (R9-19) sign requires separate approval from the Commissioner of Highways or authorised delegate. Refer to AS 1742.2 Clause I.4.4 for the numbered notes associated with Figure 5.1.

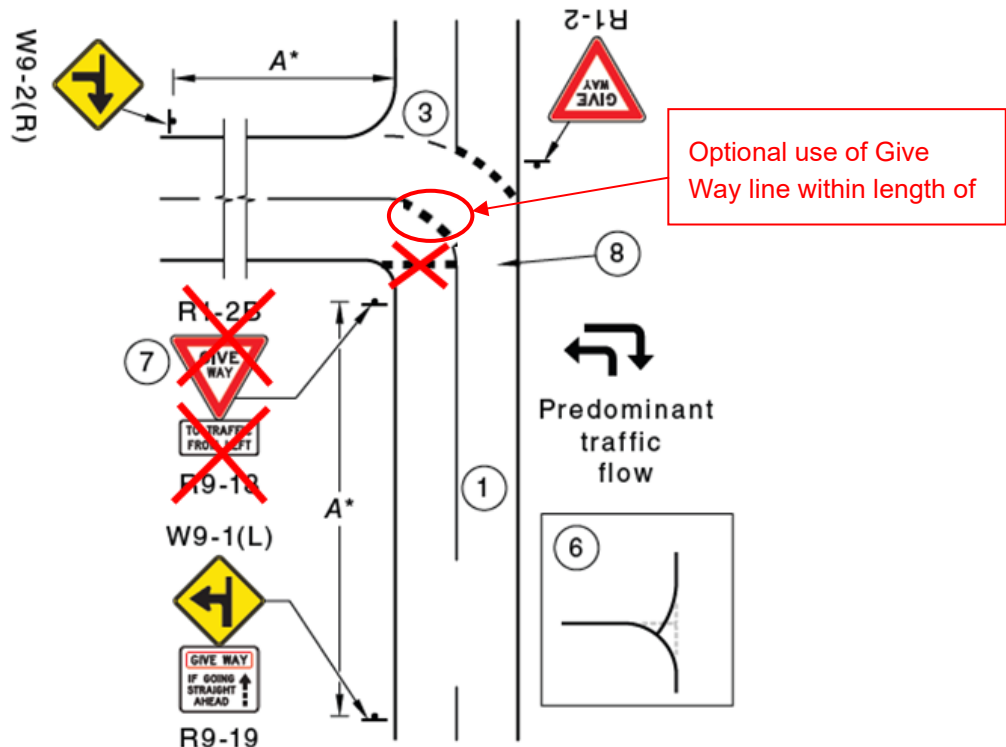

(c) T-intersection: interim treatment where raised island is not possible

Figure 5.1 Alternative to AS 1742.2 Figure I.4(c)

6. Traffic signals

6.1. Intersection signals

The design, installation and operating procedures of traffic signals at intersections shall conform to the requirements contained in *AS 1742.2 MUTCD Part 2: Traffic control devices for general use*, *AS 1742.14 MUTCD Part 14: Traffic signals* and *Austrroads Guide to Traffic Management and Guide to Road Design* (various parts).

Key traffic management considerations for traffic signals at intersections (including numerical guidelines) are contained in *Austrroads Guide to Traffic Management Part 6: Intersections, Interchanges and Crossings Management (2020)* table 3.11.

A graphical representation of this table is shown in Figure 6.1. This figure may assist in assessing the demand for traffic signals. Movement A represents the vehicles per hour on both approaches on the major road, and Movement B represents the corresponding vehicles per hour on the higher volume minor road approach. For the four one-hour periods on an average day plotted on this graph, if all four points are either above the blue line (traffic volume criteria), or above the red line (continuous traffic criteria), traffic signals may be appropriate for the intersection.

The traffic volumes considered in relation to these guidelines shall exclude the left turning vehicles, unless the volume of left turning vehicles is such that it will adversely affect the other movements at the intersection.

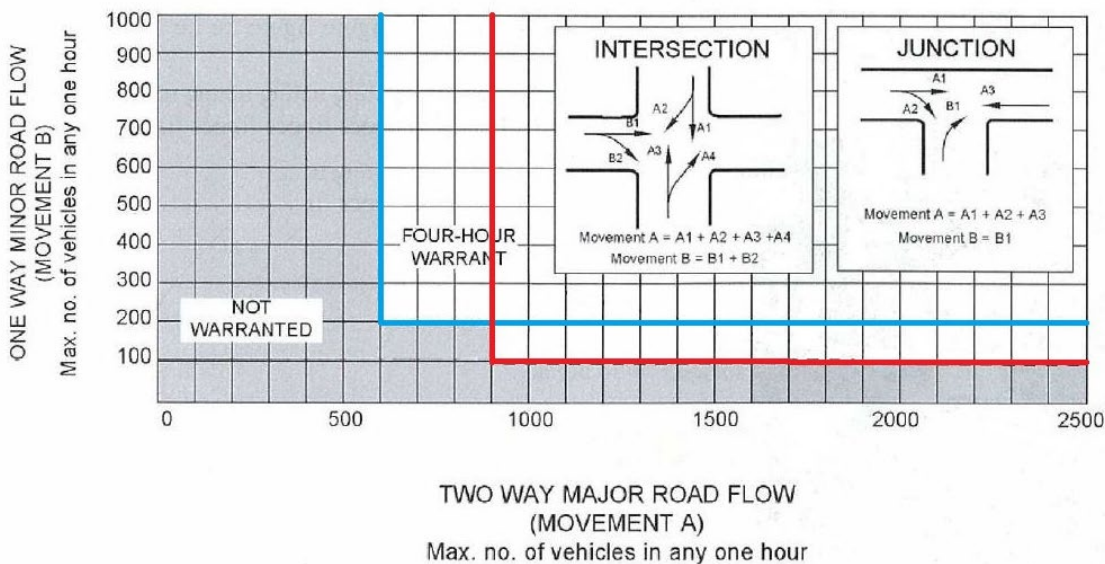

Figure 6.1 Numerical guideline for traffic signals at intersections

Where Figure 6.1 indicates that traffic signals may be appropriate, detailed analysis of the intersection should then be undertaken with the aid of computer modelling programs, taking into account factors such as weekday morning and evening peaks, business peaks and any known special event peaks.

The following factors should also be taken into consideration in assessing the need for traffic signals:

- Role and function of the road
- Speed environment
- Competing priority for traffic signal control at other locations
- Local road access issues
- Public transport access
- Crash history. While traffic signal control is likely to reduce the severity of certain types of crashes it is important to note that the number of crashes, particularly rear end crashes, may increase. As right turn crashes may continue to occur if filter right turns movement are permitted, new traffic signal installations shall not allow for filter right turns.

For traffic signals on roads under the care, control and management of the Commissioner of Highways, the modelling shall be scoped, defined and reviewed by DIT's Network Management Services.

6.1.1. Pedestrian push buttons

Audio-tactile "push button" devices installed in conjunction with traffic signals shall comply with the requirements contained in *AS 2353 Pedestrian push-button assemblies* and DIT's *Supplement to AS 1742.10* Clause 5.2(d). (www.dit.sa.gov.au/?a=1229509)

6.1.2. Pedestrian countdown timers

Where used, pedestrian countdown timers shall comply with *Operational Instruction 14.2 Traffic Signal Faces*. (www.dit.sa.gov.au/?a=40178)

6.1.3. Scramble pedestrian crossings

Scramble pedestrian crossings, as detailed in *Operational Instruction 14.1 Scramble Pedestrian Crossings*, shall only be used with separate approval of the Commissioner of Highways or his/her authorised delegate. (www.dit.sa.gov.au/?a=40177)

6.1.4. Give Way to Pedestrians

The Give Way to Pedestrians (R2-10) sign (*AS 1742.14 MUTCD Part 14: Traffic signals (2014)* clause 6.1.2 (b)) sign shall not be used. The (Left or Right) Turn Give Way to Pedestrians & Cyclists (R2-SA102) sign may be used as an alternative, in accordance with the guidance provided in *AS 1742.14 MUTCD Part 14: Traffic signals (2014)* clause 6.1.2 (b).

For treatment at slip lanes, refer to DIT's *Supplement to AS 1742.10*.

6.1.5. U-turn permitted

The U-turn permitted (R2-15) sign (*AS 1742.14 MUTCD Part 14: Traffic signals* (2014) clause 6.1.2(c)) shall only be used with separate approval of the Commissioner of Highways or his/her authorised delegate. It shall be used only at intersections where:



R2-15

- Geometry is sufficient to allow the U-turn to be made in one manoeuvre by all vehicles;
- There are no conflicts with the u-turning vehicle and other vehicle movements from the side road ie slip lanes;
- There is a fully controlled right turn phase;
- There are no conflicts with pedestrians crossing the road on a pedestrian phase; and
- The lane from which the u-turn is performed is an exclusive right-turn lane sheltered within a raised median.

Where used, the R2-15 sign shall be accompanied with the On Green Arrow (R9-SA107) sign.

Where there are multiple right turn lanes, the u-turn may only be performed from the furthest right lane. This shall be reinforced by the use of pavement marking arrows and lane status signs. In this situation, the R2-15 sign shall be installed on the additional primary signal post only (refer *AS 1742.14 MUTCD Part 14: Traffic signals* (2014) figure 4.1(b)) and a second R2-15 sign on the secondary post is not required. This is intended to limit the visibility of the sign to only the lane which it applies to.

6.1.6. No U-turn

The No U-turn (R2-5) sign (*AS 1742.2 MUTCD Part 2: Traffic control devices for general use* (2022) clause 2.8.4) is not used at signals as U-turns at signals are prohibited under the *Australian Road Rules*. However, where there is a change in traffic conditions upstream or downstream of the signals resulting in a loss of U-turn opportunities along the road (for example the installation of raised medians or continuous lane line for a tram lane), this may result in significant numbers of drivers breaching this rule. In the event that additional enforcement does not result in an improvement in driver compliance, the road authority may seek approval for the use of this sign at signals from the Manager, Traffic Services.



R2-5

6.2. Emergency services traffic signals

Emergency services traffic signals shall be provided with flashing signals in accordance with *AS 1742.14 MUTCD Part 14: Traffic signals* (2014) clause 7.1(b) and *Operational Instruction 14.2 Traffic Signal Faces*. Dimensions for these signals are specified in Appendix C.



R6-9

A stop line shall be provided at emergency service traffic signals. The Stop on Red Signal sign (R6-9), as distinct from the Stop Here on Red Signal sign (R6-6), shall be used in conjunction with these signals, to reflect the application of *Australian Road Rules* Rule 56(1)(a) rather than Rule 56(1)(b) at these signals.

Emergency services traffic signals shall only be operated for use by an emergency vehicle (in accordance with the definition in the *Australian Road Rules*) and shall not be operated at other times.

6.3. Flashing yellow traffic lights

Flashing yellow traffic lights, including flashing yellow arrows, shall only be used as a temporary measure when there is a traffic signal malfunction.

Pelican crossings, as specified in *AS 1742.14 MUTCD Part 14: Traffic signals* and *AS 1742.10 MUTCD Part 10: Pedestrian control and protection*, shall not be used.

7. Roundabouts

7.1. General

A roundabout comprises a central island, with splitter islands, signs, pavement marking and kerb extensions designed to restrict drivers to a safe entry speed, and guide them through the roundabout. The signs and pavement markings associated with roundabouts shall be installed in accordance with *Austrroads Guide to Road Design Part 4B, AS 1742 MUTCD Part 2: Traffic control devices for general use* and the *DIT Pavement Marking Manual*, and *AS 1742.13 MUTCD Part 13: Local Area Traffic Management* for small diameter roundabouts.



Figure 7.1 Typical local street roundabout

A roundabout is a traffic control device and the use of a roundabout and the associated signs and pavement markings are included under Council's Instrument of General Approval and do not require separate approval from the Commissioner of Highways or authorised delegate when used in accordance with the relevant Australian Standards and Austrroads guides, and the variations and additions contained in this section.

Geometric design guidance for roundabouts in low speed or local street environments is provided in [Appendix C](#) for reference purposes. This approach has historically been used as the basis for local roundabout design in South Australia.

Further guidance on roundabout design is provided in the *Austrroads Guide to Road Design Part 4B* and *Guide to Traffic Management Part 6*. The geometric design decisions are the responsibility of the designer and the relevant road authority and do not require separate approval from the Commissioner of Highways or authorised delegate. The designer must use sound, professional judgement in developing the design and take into account the available guidance to assist in making those judgements.

7.2. Construction

A roundabout shall not be installed unless the intersection is sealed and all approach roads are sealed for sufficient distance to ensure the roundabout operates safely.

The Roundabout sign (R1-3) shall be installed on every approach of a roundabout once construction of the central island has begun and vehicles are required to travel in a clockwise direction around the central island. All GIVE WAY, STOP and advance warning signs installed for the original intersection, if any, shall be immediately removed or covered.



R1-3

7.3. Roundabouts on bus routes

Before a roundabout is installed on an existing or intended bus route, consultation shall take place with the South Australian Public Transport Authority (SAPTA) - Integrated Service Planning section and bus operators.

8. Pedestrian crossings

8.1. General

Pedestrian crossing facilities shall be installed only in accordance with *AS 1742.10 MUTCD Part 10: Pedestrian control and protection*, *Austrroads Guide to Traffic Management Part 6: Intersections, Interchanges and Crossings*, *Austrroads Guide to Road Design Part 4: Intersections and Crossings* and the variations and additions contained in DIT's [Supplement to AS1742.10 \(www.dit.sa.gov.au/?a=1229509\)](http://www.dit.sa.gov.au/?a=1229509).

The previous content of this section, *Operational Instruction 10.4* and *Operational Instruction 10.6* is now contained in the *Supplement to AS 1742.10*.

9. Parking

9.1. General

The requirements dealing with parking controls are contained in *AS 1742.11 MUTCD Part 11: Parking controls*, *AS 2890.1 Parking facilities – Off-street car parking*, *AS 2890.5 Parking facilities – On-street car parking*, *AS 2890.6 Parking facilities – Off-street parking for people with disabilities* and in accordance with the [Australian Road Rules](#) under the *Road Traffic Act 1961*.

<http://www.legislation.sa.gov.au/LZ/C/R/Australian%20Road%20Rules.aspx>

The installation of parking zones shall conform to the minimum parking distances contained in the *Australian Road Rules*. Refer to *Austrroads Guide to Traffic Management Part 11 – Parking Management Techniques* for considerations which may necessitate the extension of these distances.

If indented parking or kerb extensions are provided at a pedestrian crossing facility, the minimum parking distances contained in the *Australian Road Rules* may be reduced, provided an assessment is undertaken to ensure that a sight triangle at the crossing facility remains unobscured by parked cars, landscaping, or street furniture. For the sight distance requirements at crossings, refer to Section 3.3 of *Austrroads Guide to Road Design Part 4A – Unsignalised and Signalised Intersections (2017)* and Section 8.2.2 of *Austrroads Guide to Road Design Part 4 – Intersections and Crossings - General (2017)*.

Existing on-street parking zones lawfully established before the introduction of the *Australian Road Rules* (December 1999) may remain provided they comply with the requirements of *Austrroads Guide to Traffic Management Part 11 – Parking Management Techniques* and *AS 2890.5 Parking facilities – On-street car parking*, particularly in relation to sight distance (refer *Austrroads Guide to Road Design Part 4* and *Part 4A*) and protection of parking from through traffic, including cyclists.

Guidance on the design of the parking spaces, including the determination of parking bay dimensions and manoeuvring space is provided in the *AS 2890 Parking facilities* series, and the *Austrroads Guide to Traffic Management Part 11 – Parking Management Techniques*. The use of the off-street car parking standard in on-street areas may be acceptable where the combination of vehicle volumes, speed and the road environment create an environment which makes it reasonable for through drivers to anticipate parking and un-parking manoeuvres. The geometric design decisions are the responsibility of the designer and the relevant road authority and do not require separate approval from the Commissioner of Highways or authorised delegate. The designer must use sound, professional judgement in developing the design and take into account the available guidance to assist in making those judgements.

The pavement markings and signs associated with the parking controls shall be installed only in accordance with *AS 1742.11 MUTCD Part 11: Parking controls*, *Austrroads Guide to Traffic*

Management Part 11 – Parking Management Techniques, the DIT Pavement Marking Manual, and the variations and additions contained in this section.

9.2. Parking control signs requiring separate approval

Clearway (R5-50) and End Clearway (R5-51) signs may only be used with separate approval from the Commissioner of Highways or authorised delegate.

9.3. Drop off and pick up zones

Passenger loading zones, commonly referred to as “kiss-n-drop” zones, are typically signed with a No Parking (R5-40 or R5-41) sign, which prohibits parking but allows drivers to stop and drop off or pick up passengers or goods in accordance with ARR Rule 168.

Often these signs are supplemented with additional explanatory signs (eg on school fences) to further explain the intent of the zone and remind drivers of the requirements of the road rule, such as the need to remain with their vehicle.

An alternative method for signing these zones is the use of two minute permissive parking signs (R5-12), which provides the same time limit as the No Parking signs but provides drivers with a more positive message which may be easier to comprehend. This is a standard sign available for use by Councils in AS 1742.11 MUTCD Part 11: *Parking controls*.

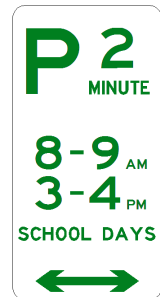

9.4. Angle parking

Austrroads *Guide to Traffic Management Part 11 – Parking Management Techniques* provides guidance on the relative merits of front-in versus rear-in (or reverse-in) parking. Where 90 degree parking is to be restricted to front-in only, it shall be signed ‘FRONT IN’, as Rule 210 (3) of the *Australian Road Rules* permits either front-in or rear-in parking in 90 degree parking spaces unless otherwise signed. Figure 9.1 shows an example of a typical sign for 90 degree parking where pavement marking of the parking spaces is provided. Figure 9.2 shows an example of a typical sign for 90 degree parking without pavement marking.



Figure 9.1 Example of sign for 90 degree parking with pavement marking



Figure 9.2 Example of sign for 90 degree parking without pavement marking

9.5. Centre-of-road parking

Parking on a central portion of a road is only permitted within a road-related area which is physically separated from the road. The access to and egress from individual parking spaces shall not be directly from or to a road.

9.6. Temporary parking

Temporary parking signs may be used where changes to the existing parking conditions are required for a limited period, such as during an event.

The signs shall conform to *AS 1742.11 MUTCD Part 11: Parking controls* and include the words 'TEMPORARY PARKING CONTROL'.

Signs shall be mounted and positioned in accordance with *AS 1742.11 MUTCD Part 11: Parking controls*, except in the following situations:

- (a) Temporary No Stopping signs may be positioned within angled or indented parking bays or on the footpath. The sign shall be clearly visible to drivers at all times, and existing parking control signs shall be covered; or
- (b) Temporary No Stopping signs shall be securely placed over existing parking control signs.

Under (a) and (b) above, temporary parking signs shall not create a hazard to road users, including pedestrians.

9.7. Electric vehicle parking

On 30 March 2024, two new parking offences relating to electric vehicles parking and charging come into effect in South Australia. The first prohibits parking in a designated electric vehicle parking area (Rule 203B). The second prohibits parking in an electric vehicle charging area, when the vehicle is not being charged (Rule 203C).

The *Australian Standard AS 1742.11 MUTCD Part 11: Parking controls*, which will specify the requirements for signs and pavement markings to reflect the new rules, is in the process of being updated. In the interim, the following guidance is provided for Councils or other road authorities wishing to adopt these new signs for electric vehicle parking. See [Section 1.4.1](#) for information on delegations and powers of approval for the installation of traffic control devices (including parking control signs).

The following examples show how the electric-powered vehicle symbol (Rule 203B) and the electric-powered vehicle charging symbol (Rule 203C) in regulation 19A of the *Road Traffic (Road Rules – Ancillary and Miscellaneous Provisions) Regulations 2014* are to be shown on parking control signs:



Figure 9.3 Examples of parking control signs showing use of electric-powered vehicle symbol and electric powered vehicle charging symbols

While Regulation 19A(4) recognises black, red or green car and power cord symbols on a white background, the design of new parking control signs for enforcement under Rules 203B and 203C should follow the convention of a green symbol for permissive parking control signs with the user limitation term “ONLY”, and a red symbol for parking control signs indicating a parking prohibition, with the user limitation term “EXCEPTED” (refer AS 1742.11 (2016) clause 3.3.4). Refer to AS 1742.11 (2016) Appendix C for detailed guidance on the design of parking control panels.

While the new rules allow for pavement marking of the electric-powered vehicle symbol or the electric-powered vehicle charging symbol as a regulatory device, it is preferable that all applicable parking spaces are identified by the relevant sign(s). Typically, the standard requirement for parking controls is that they are indicated by signs, with pavement markings supporting the message to drivers indicated by the signs. If a pavement marking is provided, it must not cause ambiguity or conflict with the signs in relation to which rule (203B or 203C) it is intended to reflect. Standard pavement markings are currently being developed and will be provided in the next update to DIT’s *Pavement Marking Manual*.

NOTE: The R5-SA167 sign on the *DIT Sign Index* shows examples of No Stopping and No Parking signs with an exception for electric vehicles, developed prior to an electric-powered vehicle symbol being recognised by regulation. These designs allowed for the signs to be supplemented with “While Charging” wording to ensure only electric vehicles while charging occupied parking spaces at the charging facility. These signs allowed enforcement under the Australian Road Rules 167 and 168 respectively.



9.8. Electric vehicle charging infrastructure on roads

Electric vehicle charging facilities are best located within Council managed roads/property or on private property, where there are low traffic volumes, a low speed environment, and the potential for conflict between road users and the proposed infrastructure and its users is less likely to become problematic. The provision of these facilities within the road reserve of arterial roads is generally not appropriate.

In considering the suitability of a location for electric vehicle charging, Council should carefully consider the impact of the infrastructure and its management on pedestrians, particularly within the highly pedestrianised environments. Council should be fully satisfied that the pedestrian environment is suitably assessed so that access and mobility is not constrained, and the facility is consistent with all Austroads and Australian Standard requirements. Council should also consider whether the proposed facility provides the best use of the road space, particularly in terms of parking availability for all road users.

The impact of the charging infrastructure on cyclists should also be considered, in particular where charging infrastructure is provided in conjunction with parallel parking. In these situations, left side charging facilities only should be considered to avoid encroachment by the cable and cable connector into the road space typically occupied by cyclists, especially where a bicycle lane is present. In order to achieve left side charging only, the charging cable should be designed so that it cannot physically reach the right-hand side of the parking space. The site would need to be identified on all user apps and associated marketing and on-line information as a 'left side charging unit only'.

Charging cables should be retractable so that they are fully contained with the unit when not in use and minimise any excess cable being exposed when in use, as this excess cable may cause a hazard to pedestrians and cyclists.

10. Local Area Traffic Management

10.1. General

The devices contained in this section are generally used as part of a local area traffic management (LATM) scheme. LATM schemes involve the use of physical devices, landscaping treatments and other measures to influence behaviours with the objective to reduce traffic volumes and speeds in local streets to increase liveability and improve safety. LATM devices shall only be installed on sealed roads.

LATM devices shall be installed only in accordance with *AS 1742.13 MUTCD Part 13: Local area traffic management*, *Austrroads Guide to Traffic Management Part 8: Local Street Management*, and the variations and additions contained in this section.

Before LATM devices are installed, consultation shall take place with emergency (fire and ambulance) services. Where an LATM device is proposed on an existing or intended bus route, consultation shall take place with the South Australian Public Transport Authority (SAPTA) - Integrated Service Planning and bus service operators. The needs of heavy vehicle operators should also be considered.

LATM devices shall accommodate the needs of pedestrians and cyclists, with cyclist bypasses provided where appropriate.

10.1.1. Devices used in series

Devices such as slow points, road humps and road cushions are generally used in series along a road to maintain low vehicular speeds occurring at the entrance to the treated road and to discourage use by through traffic. These devices may be used in isolation on short sections of road.



Figure 10.1 Single lane slow points

10.1.1.1. Entry to treated roads

Vehicles entering the road or section of road treated with road humps, road cushions or slow points must be restricted to low speeds. The following are examples of treatments which would achieve this:

- (a) All vehicles are forced to make a low speed turn such as at a roundabout, or 90° bend or turn.
- (b) Vehicles are controlled by a STOP sign (in accordance with [Section 5.1](#)).
- (c) Vehicles are controlled by a GIVE WAY sign, provided:
 - (i) the uncontrolled road to be crossed is an arterial road; or
 - (ii) all vehicles entering the treated road are constrained to 20 km/h or less by permanent physical site features.
- (d) Another low speed geometric arrangement for example, a driveway entry or driveway link.

Traffic signals do not restrict vehicles to low speeds in all cases. Therefore, they shall not be considered as a means to control the speed of vehicles entering a treated road.

10.1.1.2. Location and siting of devices

The *Austroads Guide to Traffic Management Part 8: Local Street Management* (2020) Sections 4.3.2 and 9.3 provide guidance on spacing of devices. *Austroads Guide to Traffic Management Part 8: Local Street Management* (2020) Section 9.1 recommends that the first device encountered should be placed where it can be clearly seen and speeds are naturally low. Ideally, it should be located within 50 m of the start of the road.

Road humps, road cushions and slow points should not be installed on arterial roads, or roads with a speed limit greater than 50 km/h. They should not be installed on roads with a gradient exceeding 10% unless, in accordance with *Austroads Guide to Traffic Management Part 8: Local Street Management* (2020) 'a comprehensive risk management assessment process is conducted and all necessary requirements are appropriately addressed'.

10.1.2. Kerb extensions

A kerb extension is formed by the construction of a raised island adjacent to the kerb, or by extending the kerb to create a localised narrowing of the road.

Other methods of narrowing the road include the use of pavement marking, pavement bars and RRPMS as described in the [*DIT Pavement Marking Manual*](http://www.dit.sa.gov.au/?a=40257) (<http://www.dit.sa.gov.au/?a=40257>), however these are not 'kerb extensions'.

Kerb extensions may form part of an LATM device. They may also be used at pedestrian crossing facilities to minimise crossing distances.

The pavement markings for kerb extensions may be augmented by frangible or flexible posts with retroreflective devices permanently attached. Unidirectional hazard markers may be used as an alternative where additional delineation is required, however the associated reduction in visual amenity of the streetscape should be taken into consideration. Excessive use of signs should be avoided.

Ideally, a kerb extension should be incorporated in the road verge or nature strip with drainage diverted, channelled underground or incorporated into landscaping to remove the need for a drainage channel between the kerb extension and the existing kerb. Such a channel has the potential to be a hazard to pedestrians. Pedestrians should be prevented from inadvertently stepping into this channel with the use of landscaping, or by physically covering the channel. This requirement does not apply if the channel forms part of a bypass of the device for cyclists.

For typical kerb type details, refer to *DIT Standard Drawing S-4074 Sheet 5*.

10.2. Perimeter thresholds

Perimeter thresholds shall be installed only in accordance with *AS 1742.13 MUTCD Part 13: Local area traffic management*, *Austrroads Guide to Traffic Management Part 8* and the variations and additions contained in this section.

Perimeter thresholds should incorporate a combination of kerb extensions, raised medians and contrasting pavement. Where contrasting pavement is used at a perimeter threshold, it shall be either at grade in accordance with [Section 10.3](#), or raised in accordance with a mid-block raised pavement as per *Austrroads Guide to Traffic Management Part 8* section 7.2.5 and flat-top road hump of minimum 6 m length (refer [Section 10.6](#)).

10.2.1. One lane perimeter thresholds

A perimeter threshold as described in *AS 1742.13 MUTCD Part 13: Local area traffic management* and *Austrroads Guide to Traffic Management Part 8* may be combined with a single-lane slow point to provide for one lane, two-way traffic operation. The lane may either be located centrally between kerb extensions or offset to one side of the road between a kerb extension and the existing kerb. The offset shall favour the vehicle exiting from the treated road (see Figure 10.2).

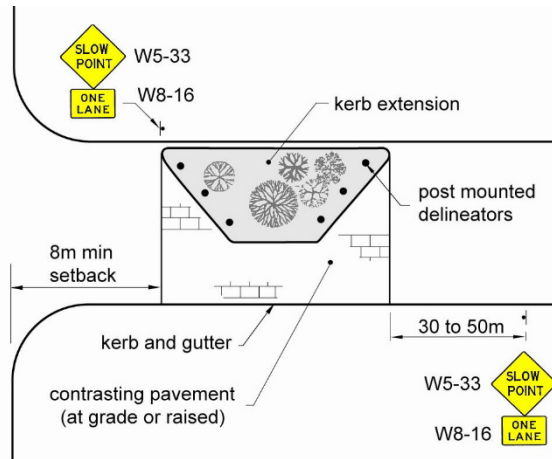

Figure 10.2 Offset one lane perimeter threshold

A one lane perimeter threshold shall be installed at a sufficient distance from an intersection to allow vehicles from the major road to wait in the treated road for vehicles leaving the perimeter threshold. For an offset perimeter threshold the minimum setback is 8 m and the maximum setback should equal the likely queue length of vehicles entering from the major road.

It shall be signed as a single lane slow point. The need for a Road Hump sign (W5-10) with One Lane supplementary plate (W8-16) should be considered in lieu of the Slow Point sign (W5-33) for a raised perimeter threshold. A Give Way sign (R1-2) shall not be erected to assign priority to a one lane perimeter threshold.

10.3. Contrasting pavements

Pavement that is clearly different in appearance from the surrounding road is called 'contrasting pavement'.



Figure 10.3 Contrasting pavement on approach to an intersection

While contrasting pavement is not considered to be a traffic control device, the requirements for its use in this section are specified in order to prevent it from being misinterpreted as a traffic control device. Pedestrians may perceive a strip of contrasting pavement across a road as a type of crossing which gives them priority over vehicles. To prevent this potentially hazardous situation, contrasting pavements shall be a minimum length or pedestrians shall be prevented from crossing there.

10.3.1. Mid-block

Contrasting pavement shall extend at grade across the full width of the road and shall either be:

- (a) at least 12 m in length; or
- (b) where less than 12 m in length, pedestrians shall be discouraged from crossing the road at that point with treatments such as landscaping or a low fence. These treatments shall extend along the full length and on each side of the contrasting pavement and adjacent to or on the footpath. Refer to Section 1.7 on Pedestrian related hazards. Contrasting pavement shall not be less than 6 m in length.

10.3.2. Intersection

Where contrasting pavement is installed at an intersection, the paving shall extend into the approach roads by a minimum length of 8 m.

This length is measured from point of intersection of the prolonged edge of the adjacent road closest to the particular approach road (see Figure 10.4).

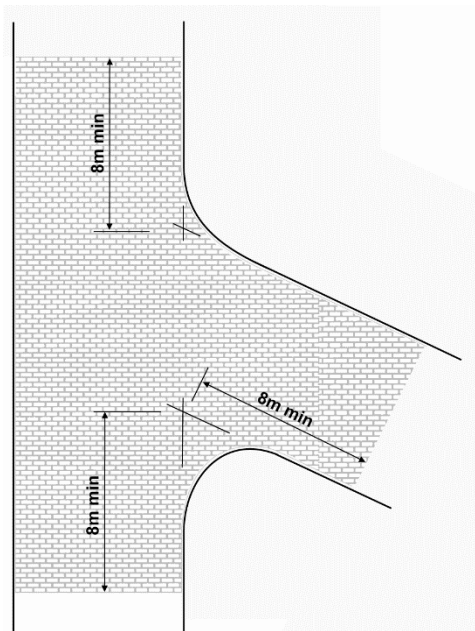

Figure 10.4 Contrasting pavement

Where contrasting pavement is installed on only a single approach i.e. not including the intersection or T-intersection it shall be at least 12 m in length.

10.4. Road murals

A road mural is any piece of 'artwork' painted or applied directly to a road surface. It may be used for street beautification, urban design or place-making purposes to highlight to drivers that they are entering a different environment, which may encourage them to be more alert to the surroundings and slow down.

A road mural shall be located and designed to not adversely affect the safety of road users and to ensure that road user guidance is not compromised. Road murals should not create a significant distraction to road users and should be designed to be easily understood by glance appreciation.

Where DIT is involved in the funding of the artwork, endorsement of the design and conformance with the paint specification and application process is required from the relevant technical areas of the Department.

10.4.1. Mural design requirements

The following requirements and recommendations apply to the design of road murals:

- (a) Artwork must not create a significant distraction to road users.
- (b) The size and orientation of the design shall be such that pedestrian viewing of the road mural is undertaken from the footpath, where one is available.
- (c) Road murals shall not contain any features that could be confused with a traffic control device. To assist with this, colours defined in the [DIT Pavement Marking Manual \(http://www.dit.sa.gov.au/?a=40257\)](http://www.dit.sa.gov.au/?a=40257) or the Australian Standards for traffic control devices should not be used in a way which may be confused with their standard traffic control devices usage, and road murals should not incorporate colours schemes that may interfere with traffic signals. Any lines within the road mural should not be of a width similar to that of a standard road marking and shall not be aligned in such a way as to infer a path of travel for drivers, cyclists and pedestrians. Shapes commonly used on regulatory traffic control devices such as equilateral triangles and octagons, or shapes such as arrows, diagonal stripes or chevrons should not be used, particularly in isolation, to avoid drivers interpreting the artwork as having a formal meaning. The use of geometric shapes in an irregular pattern present less of a risk of misinterpretation by drivers.
- (d) Where possible, the artwork should be associated with the land use adjacent to the road on which the artwork is being applied. There may be opportunities to involve the local community in the project and encourage their interest and involvement in local road safety issues.
- (e) Road murals shall not include any commercial or company logo, or advertising.
- (f) Road murals shall not contain messages or content of a salacious, illegal or controversial nature.

- (g) The road mural design shall be certified by an experienced traffic engineering practitioner to ensure that the installation complies with the requirements of this section and is not a potential traffic control device or facsimile.

10.4.2. Mural location requirements

The following requirements and recommendations apply to the location of the road murals:

- (a) Road murals shall not be installed on or near roads under the care, control and management of the Commissioner of Highways.
- (b) Road murals shall only be used on roads with a speed environment of 60 km/h or less.
- (c) Road murals shall not be used as or with a traffic control device. There must be adequate separation between a road mural and a traffic control device to avoid any association between the two features.
- (d) A road mural shall be positioned and designed such that it does not resemble a pedestrian crossing and could not be confused as such.
- (e) A road mural installation should meet the requirements for contrasting pavements as set out in Section 10.3 to assist in avoiding being perceived as a pedestrian crossing, and to be of sufficient size to allow glance appreciation.
- (f) Road murals should be located so as to not interfere or cause confusion with the safe operation of intersections or median openings.
- (g) Road murals should not be located on or near sharp bends or crests.
- (h) On-street parking should be considered when locating the mural as parked vehicles may impact on the visual appeal and effectiveness of the design.
- (i) Road murals in areas where heavy acceleration and braking occur will exhibit a higher degree of wear and this should be taken into account when locating the mural.
- (j) Lighting shall not be installed to specifically illuminate the road mural.
- (k) Road murals shall not be reflectorized, however the addition of quartz for its skid resistance properties is recommended.
- (l) Any crash history at the site of a proposed road mural should be taken into consideration to avoid the potential perpetuation of a crash risk.

10.4.3. Skid resistance

Road murals shall be skid and slip resistant to the requirements of *AS 4049 Paint and related materials – Pavement marking materials* and the [DIT Pavement Marking Manual](http://www.dit.sa.gov.au/?a=40257) (<http://www.dit.sa.gov.au/?a=40257>) so as not to cause a hazard for road users.

Prior to installation of an artwork, the road surface shall be tested to determine its skid resistance. If testing indicates that the pavement is due for maintenance, which when undertaken would cover or remove the artwork, it is recommended that the artwork be postponed until the maintenance work was completed.

The road with new artwork must be tested for skid resistance within seven (7) days of application. If the skid resistance does not satisfy the skid resistance investigatory levels recommended in [DIT Technical Note 24 – Road Surface Friction \(Skid Resistance & Pavement Texture\) Recommended Investigatory Levels](http://www.dit.sa.gov.au/) (<http://www.dit.sa.gov.au/>

?a=47525), then measures must be put in place to reduce further risk, such as warning signage, traffic calming devices or removal of non-compliant artwork.

Skid resistance testing can be arranged by contacting DIT's Technical Services.

For further information and guidance, refer to Austroads *Guide to Asset Management Part 5F: Skid Resistance*.

10.4.4. Paint specification

Road murals shall not be reflectorized. The specification and application of the paint shall be in accordance with DIT's *TP915 – Use of a Certified Road-Marking Paint for Murals on a Vehicular Road Surface* (currently draft version – contact DIT's Technical Services)

10.5. Raised pavements

Raised pavements shall be installed only in accordance with *AS 1742.13 MUTCD Part 13: Local area traffic management*, *Austroads Guide to Traffic Management Part 8: Local Street Management* and the variations and additions contained in this section.

The ramp grades specified for raised pavements in the *Austroads Guide to Traffic Management Part 8: Local Street Management* are relative to a longitudinal road gradient of 0%, and will vary depending on the existing longitudinal grade of the pavement surface. The longitudinal grade of the platform will generally match the longitudinal grade of the road.

Where unusual road geometry makes it difficult to achieve the geometry requirements of the *Austroads Guide to Traffic Management Part 8: Local Street Management*, the designer should ensure that clearance for the B99 vehicle is achieved.

To control vehicle speeds along a length of road, raised pavements may be used at intersections in conjunction with a series of flat-top road humps.

Raised pavements may also be used as a standalone device to control vehicle speeds at intersections as part of a local area traffic management scheme.

The requirements for road hump markings in *AS 1742.13 MUTCD Part 13: Local area traffic management* shall also apply to raised pavements. Where 'inverted piano key' markings for road humps are provided on the approach and exit ramps of the raised pavement, they shall be in accordance with the [DIT Pavement Marking Manual](http://www.dit.sa.gov.au/?a=40257) (<http://www.dit.sa.gov.au/?a=40257>).

The Road Hump sign (W5-10) with a 20 km/h advisory speed (W8-2) shall be provided at raised pavements in accordance with *AS 1742.13 MUTCD Part 13: Local area traffic management*. It may be located in advance of the raised pavement in order to avoid obstructing or detracting from the intersection control signs.

For sections of raised contrasting pavement in other situations refer to perimeter thresholds ([Section 10.2](#)) and flat-top road humps ([Section 10.6](#)).

At T-intersections where no stop or give-way lines are required (refer [Section 5](#)), the raised pavement should be confined to the intersection (see example in Figure 10.5), extend into the approaches of the intersection (see Figure 10.6), or be a combination of the two (see Figure 7). Where the raised pavement is confined to the intersection, it should be bounded by the prolongation of kerbs of the approaches, however to cater for various intersection geometry it may extend beyond this in order to ensure that any gap between the kerb and the start of the ramp is minimised.

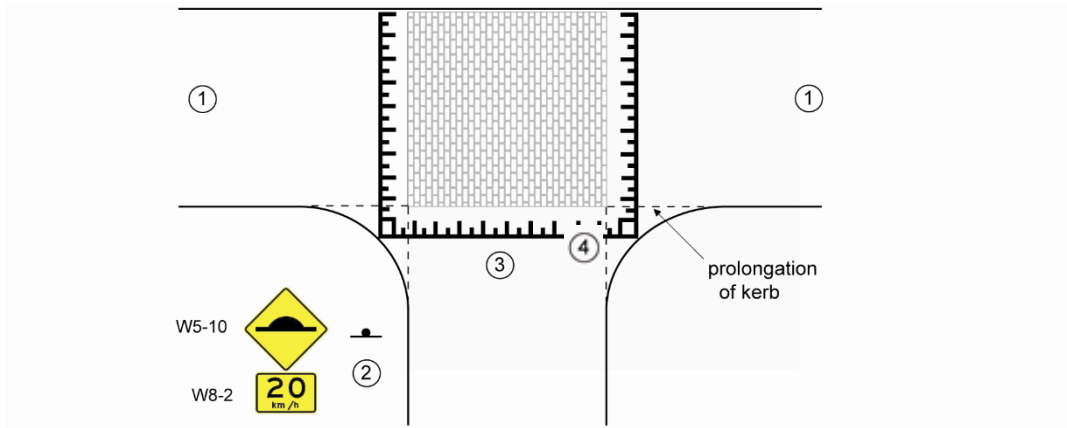

Notes:

- 1 Raised pavements may be used as part of a series of flat-top road humps
- 2 Road hump sign (W5-10) shall be used on the side approach road which does not contain the series of flat-top road humps. Where the raised pavement is used in isolation, the Road hump sign (W5-10) shall be used on all approaches.
- 3 Pavement markings shall be provided in accordance with the requirements for road hump markings in AS 1742.13. 'Inverted piano key' markings shall be in accordance with DIT Pavement Marking Manual
- 4 Where the raised pavement is confined to the prolongation of kerb, consideration must be given to the impact of the ramp on cyclist turning manoeuvres.

Figure 10.5 Raised pavement at a T-intersection (area bounded by prolongation of kerb)

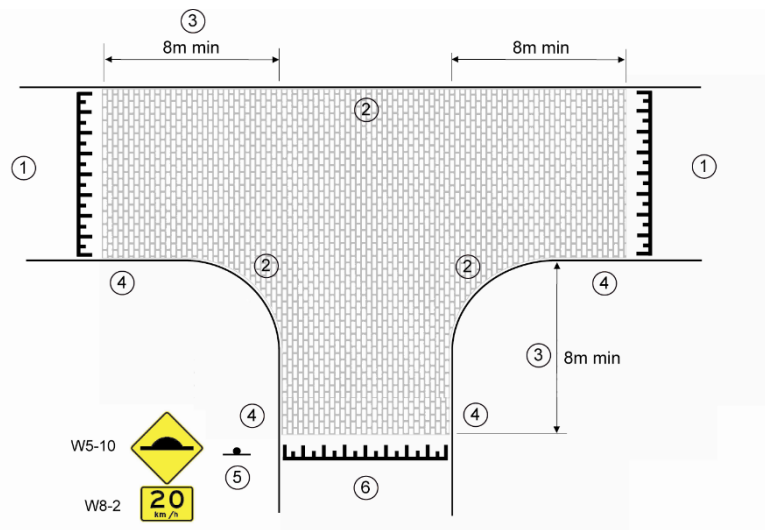

Notes:

- 1 Raised pavements may be used as part of a series of flat-top road humps
- 2 Consideration shall be given to drainage issues. If stormwater is diverted or channelled underground, the loss of delineation due to the absence of kerb and channel shall be addressed
- 3 Extent of raised paving may need to be adjusted to locate the ramp for the raised pavement clear of pedestrian desire lines. If it is impractical to extend the raised pavement into the approaches of the intersection for a minimum of 8 m, the design should include measures to prevent pedestrians from incorrectly perceiving the raised pavement as a form of pedestrian crossing.
- 4 Provisions for pedestrian access shall cater for the needs of people with disabilities. Consideration shall be given to the impact of the change in grade between the footpath and the raised pavement on accessibility for all pedestrians
- 5 Road hump sign (W5-10) shall be used on the side approach road which does not contain the series of flat-top road humps. Where the raised pavement is used in isolation, the Road hump sign (W5-10) shall be used on all approaches.
- 6 Pavement markings shall be provided in accordance with the requirements for road hump markings in AS 1742.13. 'Inverted piano key' markings shall be in accordance with the DIT Pavement Marking Manual.

Figure 10.6 Raised pavement at a T-intersection (extending into approaches)



Figure 10.7 Example of raised pavement at a T-intersection extending into approaches on two legs (Beulah Road, Norwood) (Image from GoogleMaps "Street View")

At intersections where stop or give-way lines are required, the raised pavement should extend into the approaches of the intersection (see Figure 10.8). This requirement aims to avoid confusion between the stop or give-way line marking and the 'inverted piano key' markings for the raised

pavement. Otherwise, stop or give-way lines must be clearly separate from the 'inverted piano key' markings.

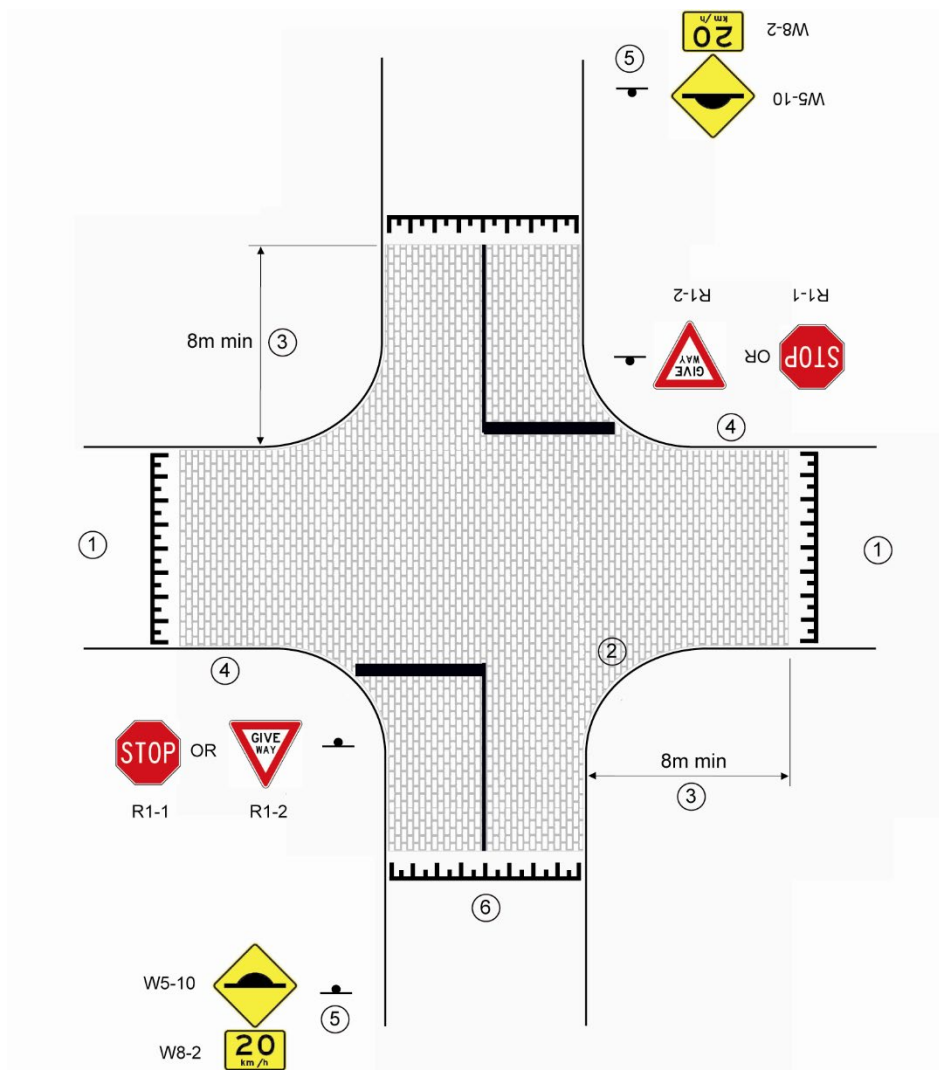

Notes:

- 1 Raised pavements may be used as part of a series of flat-top road humps
- 2 Consideration shall be given to drainage issues. If stormwater is diverted or channelled underground, the loss of delineation due to the absence of kerb and channel shall be addressed
- 3 Extent of raised paving may need to be adjusted to locate the ramp for the raised pavement clear of pedestrian desire lines. If it is impractical to extend the raised pavement into the approaches of the intersection for a minimum of 8 m, the design should include measures to prevent pedestrians from incorrectly perceiving the raised pavement as a form of pedestrian crossing.
- 4 Provisions for pedestrian access shall cater for the needs of people with disabilities. Consideration shall be given to the impact of the change in grade between the footpath and the raised pavement on accessibility for all pedestrians
- 5 Road hump sign (W5-10) may be located in advance of the raised pavement in order to avoid obstructing or detracting from the intersection control sign. Where the raised pavement is used in isolation, the Road hump sign (W5-10) shall be used on all approaches.
- 6 Pavement markings shall be provided in accordance with the requirements for road hump markings in AS 1742.13. 'Inverted piano key' markings shall be in accordance with the DIT Pavement Marking Manual

Figure 10.8 Raised pavement at a four way intersection

Where raised pavements extend into the approaches of the intersection, they should extend a minimum length of 8 metres (measured from the prolongation of the kerb) into the approach of the

intersection. Successful implementation of this treatment requires that the following issues are also addressed:

- (a) Extending the raised pavement into the approaches of the intersection may result in the ramps being positioned on or adjacent to the pedestrian desire lines. This has the potential for the raised pavement to be mistaken as a form of pedestrian crossing. In these situations, the raised pavement may need to be further extended into the approaches of the intersection. Where it is impractical to extend the raised pavement into the approaches of the intersection for 8 m, the design should include measures to prevent pedestrians from incorrectly perceiving the raised pavement as a form of pedestrian crossing. This may be achieved by physically separating pedestrian footpaths from the device by landscaping or other means.
- (b) The raised pavement may be tapered flush to the existing kerb and channel for drainage purposes, however pedestrian access issues will need to be addressed. If kerb ramps are provided for pedestrian access, but pedestrians are then required to travel from the invert level of the channel, up the tapered section of raised pavement and onto the raised pavement, the accessibility requirements of the *Disability Discrimination Act 1992* need to be met. Stormwater may be diverted or channelled underground to remove the need for a drainage channel along the kerb line, and assist in providing a more consistent grade for pedestrian movements.
- (c) If the raised pavement is provided without ramping down to a drainage channel along the kerb line, there may only be a small difference in the level of the raised pavement and the adjacent kerb. This may reduce the delineation of the intersection previously provided by the kerb and additional delineation may be required.
- (d) Raised pavements should not be installed across driveways. Where the raised pavement needs to be installed across driveways, ensure that drivers can negotiate the change in grade between the raised pavement and the driveway without damaging the vehicle.
- (e) Raised pavements shall contrast with the adjacent footpath or shared path/bicycle path pavement to avoid any similarity between the two and avoid the risk of mistaking the raised pavement treatment as a form of pedestrian crossing. Contrast between the raised pavement and the adjacent path may also assist in delineation of the intersection.

10.6. Road humps

Road humps shall be:

- Watt's profile in accordance with *AS 1742.13 MUTCD Part 13: Local area traffic management* and *Austrroads Guide to Traffic Management Part 8: Local Street Management*,
- flat-top in accordance with *AS 1742.13 MUTCD Part 13: Local area traffic management* and *Austrroads Guide to Traffic Management Part 8: Local Street Management* and the variations and additions contained in Section 10.6.2.1,
- sinusoidal profile in accordance with *Austrroads Guide to Traffic Management Part 8: Local Street Management*, or
- road cushions only in accordance with *Austrroads Guide to Traffic Management Part 8: Local Street Management* and the variations and additions contained in [Section 10.6.3](#).



Figure 10.9 Watt's profile hump



Figure 10.10 Flat top hump

10.6.1. Location and siting

Road humps and road cushions should be positioned in accordance with the requirements of Section 10.1.1.2. The entry to the treated road shall conform to the requirements of Section 10.1.1.1.

10.6.1.1. Signing of road humps on side road

Where a road hump is located on a side road at or directly after an intersection and there is insufficient room to provide drivers with warning of the hump once they have completed their turning manoeuvre, the W3-SA4 'Road hump on side road' with the Advisory Speed sign (W8-2) may be used on the through road to provide advance warning to turning drivers.



Where a road hump is located on an intersecting road in both directions at or directly after the intersection and there is insufficient room to provide drivers with warning of the hump once they have completed their turning manoeuvre, the 'Road Hump' (W5-10) with the 'On side road' (W8-SA107) supplementary plate with the may be used on the through road to provide advance warning to turning drivers.



W8-SA107

10.6.2. Road hump profiles

The cross-sectional dimension of a road hump shall be uniform across its width. In the absence of kerb extensions, the last 600 mm at each end should be tapered flush to the edge of the kerb and channel to provide for drainage.

Where a one lane road hump needs to provide for centre of road drainage, the hump should taper to either side of the channel for a length of 300 mm.

The leading and trailing edges of a road hump shall be flush with the adjacent pavement.



Figure 10.11 One lane hump with centre of road drainage

Where the road is wide enough, it is preferable to construct the road hump between kerb extensions formed with semi-mountable kerb. This eliminates the undesirable practice of drivers aligning the vehicle's left wheels close to the kerb so that only the right wheels have to traverse the road hump to reduce the effect of the road hump. This may increase the risk of the vehicle striking the kerb and losing control.

10.6.2.1. Profile of flat top road hump

The cross section of a flat top road hump shall be in accordance with *AS 1742.13 MUTCD Part 13: Local area traffic management*, *Austrroads Guide to Traffic Management Part 8: Local Street Management* Section 7.2.3, or Section 7.2.5 for mid-block raised pavements.

The ramp grades specified for road humps in these documents are based on a longitudinal road gradient of 0%, and will vary depending on the existing longitudinal grade of the pavement surface. The longitudinal grade of the platform will generally match the longitudinal grade of the road.

Where unusual road geometry makes it difficult to achieve the geometry requirements of these documents, the designer should ensure that clearance for the B99 vehicle is achieved.

If the flat top road hump is located on a bus route, the ramps shall be extended to 2.0 m, and the minimum length of the platform shall be extended to 7.0 m.

10.6.3. Road cushions

Road cushions shall be used only in accordance with *AS 1742.13 MUTCD Part 13: Local area traffic management*, *Austrroads Guide to Traffic Management Part 8: Local Street Management* and the variations and additions contained in this section.



Figure 10.12 Road cushions

The dimensions of each road cushion shall be:

Width: 1.6 m to 1.9 m

Height: 70 mm to 80 mm

Length: 2 m to 3 m

Maximum front and back grade: 1:7.5

Road cushions shall be spaced across the road to ensure that they are effective in reducing the speed of cars while allowing bus wheels to travel on either side of the cushion. The gap between kerb and cushion, or adjacent cushions (measured across the road) should not be less than 0.7 m or exceed 1.3 m. Three cushions, or two cushions in combination with kerb extensions or a median may be used to achieve this spacing. Where three cushions are used, the central cushion is not intended to be traversed and a cushion wider than 1.9 m may be used.

The impact on the travel path of cyclists shall be considered when designing the layout of the cushions. Consideration shall also be given to managing the drainage for the road.

An Advisory Speed (W8-2) of 30 km/h shall be posted for road cushions.

Contrasting markings shall be provided on the face of the road cushions such that the cushions are clearly visible under all conditions. As these markings are generally formed by inlaying non-reflectorised white rubber, road cushions shall be illuminated by street lighting.

10.6.4. Road humps and road cushions in off-street areas

Road humps in off-street areas shall be:

- flat-top in accordance with *AS 1742.13 MUTCD Part 13: Local area traffic management* and *Austrroads Guide to Traffic Management Part 8: Local Street Management* and the variations and additions contained in Section 10.6.2.1,
- road cushions only in accordance with *Austrroads Guide to Traffic Management Part 8: Local Street Management* and the variations and additions contained in Section 10.6.3, or
- off-street area Watt's profile road humps in accordance with Section 10.6.4.2.

The Type 1 and 2 road humps and associated pavement markings specified in *AS 2890.1 Parking facilities – Off-street car parking* shall not be used.

Speed control is best achieved by eliminating features such as long straight roads that enable drivers to travel at unacceptable speeds. Off-street area road humps may be used to assist in further reducing speeds to achieve a 20 km/h speed environment.

The requirements listed in Section 10.1.1 for devices used in series also apply to road humps and cushions in off-street areas except that the first hump or cushion should be within 30 m from the start of the circulation roadway with subsequent humps or cushions spaced as uniformly as practicable to a maximum of 50 m.

Off-street areas with a speed environment similar to the general urban road network (ie with 85th percentile speeds in the order of 50 km/h), may be treated with the types of road humps or cushions specified in Section 10.6, with humps or cushions located and spaced in accordance with Section 10.6.1.

The installation of road humps may create an obstacle to people with a disability or people with shopping trolleys or prams, and may present problems with drainage. Road humps should not be located on pedestrian desire lines.

10.6.4.1. Road hump warning signs in off-street areas

The Road Hump Ahead sign (W3-4), supplemented with the Advisory Speed sign (W8-2) indicating the appropriate speed for the type of hump or road cushion shall be used at the start of the circulation roadway treated. If an entire off-street area or physically separated section of an off-street area is treated with road humps or road cushions, these signs are required at the entry points only.



W3-4

10.6.4.2. Off-street area Watt's profile road humps

The cross-section of the off-street area Watt's profile road hump is a segment of a circle with length 1200 mm and height 75 mm (see Figure 10.13). The cross-sectional dimensions shall be uniform across the width of the road hump except where:

- (a) in the absence of kerb extensions, the last 450 mm at each end is tapered flush to the edge of the kerb and channel to provide for drainage; or
- (b) a one lane road hump needs to provide for centre of road drainage. In this case, 300 mm of the road hump is tapered flush to the edge of the channel.

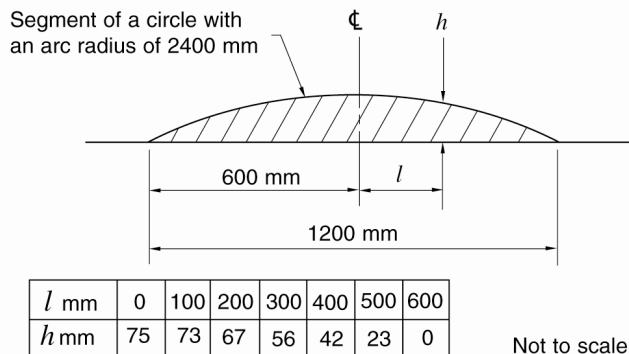

Figure 10.13 Off-street area Watt's profile road hump cross section

The W8-2 Advisory Speed sign shall indicate an advisory speed of 10 km/h for off-street area Watt's profile road humps.

Pavement markings for off-street area Watt's profile road humps shall be in accordance with the [DIT Pavement Marking Manual](http://www.dit.sa.gov.au/?a=40257) (<http://www.dit.sa.gov.au/?a=40257>).

10.7. Road closures

Road closures shall be installed only in accordance with *AS 1742 Manual of uniform traffic control devices*, *Austrroads Guide to Traffic Management Part 8* and the variations and additions contained in this section.

10.7.1. Full closure

A full road closure should create the appearance of a cul-de-sac, rather than a continuing road with a barrier across it. Care should be taken to create this appearance when selecting the type of barrier to physically close the road, while ensuring that the barrier does not itself form a hazard (refer to [Section 1.6](#)). Landscaping at the road closure will play a significant part in creating the appearance of a cul-de-sac.

As with any LATM device, the use of signs on full road closures should be kept to a minimum. Post mounted delineators, consisting of frangible or flexible posts with retroreflective devices permanently attached may be provided at the barrier to improve night time delineation of the closure. An Obstruction board (D4-SA5) may be used if additional delineation is required. The ROAD CLOSED (G9-20) sign specified in *AS 1742.2 MUTCD Part 2: Traffic control devices for general use* should not be used for the installation of full road closures in accordance with *AS 1742.13 MUTCD Part 13: Local area traffic management*.

10.7.2. Part-time closure

A part-time closure may be used where traffic is to be prevented from entering a road, or part of a road at particular times. A part-time closure consists of a barrier, generally in the form of a gate, across the road. The barrier shall not cause an unreasonable degree of hazard if struck by a vehicle (refer to [Section 1.6](#)).

The ROAD CLOSED sign (G9-20) shall be placed at the centre of the barrier. An Obstruction board (D4-SA5) may also be used if additional visibility of the barrier is required to ensure it is visible to approaching drivers under all reasonably expected weather conditions.

Operation of the part-time barrier shall be in accordance with [Section 1.4.2](#).

10.7.3. Vehicle exempt closure

A vehicle exempt road closure permits, by the use of signs, only vehicles of a particular class such as a bus or bicycle to have access through the road closure (see Figure 10.15). They are easily violated and should be used only where other treatments would be inappropriate.

The road through a vehicle exempt closure should be narrowed to one lane and be located centrally within the width of the road.

The NO ENTRY sign (R2-4) and a supplementary sign showing the exempt class or classes of vehicle shall be located on each side of the entry point to the road closure.



R2-4



R9-2



R9-3



Figure 10.15 Vehicle (bus) exempt closure

10.8. Slow points

Slow points shall be installed only in accordance with *AS 1742.13 MUTCD Part 13: Local area traffic management*, *Austrroads Guide to Traffic Management Part 8* and the variations and additions contained in this section.

10.8.1. Location and siting

Slow points shall be positioned in accordance with the requirements of Section 10.1.1.2. The entry to the treated road shall conform to the requirements of Section 10.1.1.1.

10.8.2. Design of angled slow points

Angled slow points shall be installed centrally within the overall width of the road.

The speed of vehicles negotiating an angled slow point is governed by its geometric design. The speed of traffic is reduced by forcing vehicles to travel through them along an elongated 'S' path (see Figures 10.16 and 10.18).

Drivers travelling through an angled slow point tend to use all of the available road and select as large a radius as possible for their vehicle path, to maintain as high a speed as possible through the device.

To assist the designer in producing safe, consistent and effective geometric angled slow point designs, the Standard Design Envelope (SDE) is used. A 1:200 scale SDE is included in Appendix D. The function of the SDE is to assist in the lateral placement of the critical control points of the angled slow point in relation to other components of the angled slow point.

There shall be no 'daylight' (defined in Sections 10.8.2.1 and 10.8.2.2) through the angled slow point.

10.8.2.1. One lane angled slow point

Angled slow points installed to provide for one lane operation shall have the entry located to the right of centre of the road (see Figure 10.16).



Figure 10.15 One lane angled slow point

As shown on Figure 10.16, the SDE shall contact or overlap control point 1 (an area 2 m wide and parallel to the right-hand kerb), contact control point 2 (the approach kerb extension) and contact control point 3 (the exit kerb extension) on each approach.

No 'daylight' is achieved when an imaginary line parallel to the centre-line of the road touches or overlaps both kerb extensions.

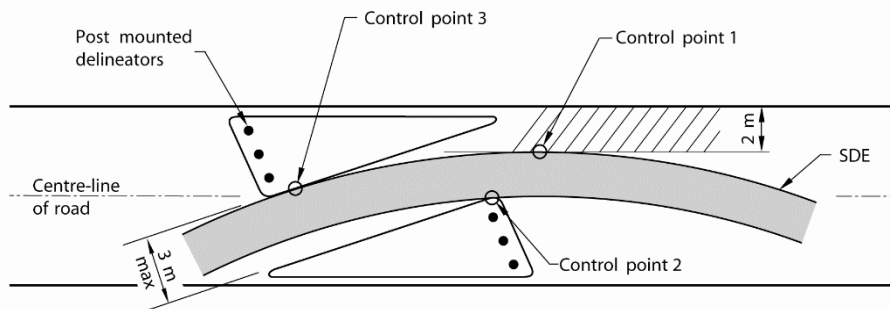

Notes:

- 1) SDE must touch or overlap the shaded area at control point 1
- 2) SDE must touch control points 2 and 3
- 3) There must be no 'daylight' through the slow point
- 4) The entry must be within the right-hand lane
- 5) The design requirements must be met for both directions of travel through the slow point

Figure 10.16 One lane angled slow point design

10.8.2.2. Two lane angled slow point

Angled slow points installed to provide for two lane operation shall use a raised central median not less than 300 mm wide to separate each lane (see Figure 10.18).



Figure 10.17 Two lane angled slow point

Pavement bar medians and dividing lines shall be installed on a curvilinear alignment for sufficient distance on approaches to the raised central median, to guide the driver into the two lane angled slow point. The raised central median may be extended into the curvilinear approaches, with a corresponding reduction in the length of the pavement bar median. Pavement bars shall be placed at a maximum of 1.5 m centres.

As shown on Figure 10.18, the SDE shall contact control point 1 (the pavement bar median), control point 2 (the kerb extension) and control point 3 (the exit end of the central median) on each approach. No 'daylight' is achieved when an imaginary line parallel to the centre-line of the road touches or overlaps the kerb extension and pavement bar median.

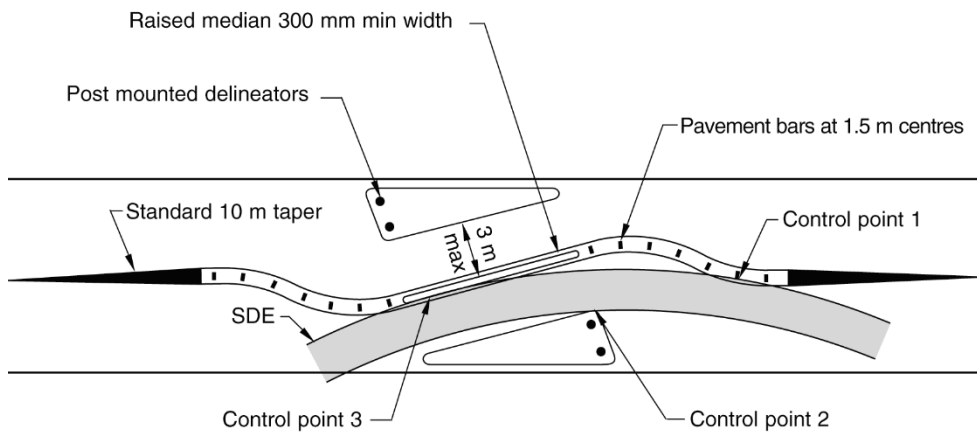

Notes:

- 1) SDE touches control points 1, 2 and 3
- 2) There must be no 'daylight' through the slow point between the kerb extension and median
- 3) The design requirements must be met for both directions of travel through the slow point

Figure 10.18 Two lane angled slow point design

10.9. Centre blister

Centre blisters shall be installed only in accordance with *AS 1742.13 MUTCD Part 13: Local area traffic management*, *Austrroads Guide to Traffic Management Part 8* and the variations and additions contained in this section.



Figure 10.19 Centre blister

A 'centre blister' is comprised primarily of an elliptical, curved, circular or diamond shaped median to create a short section of divided road. Kerb extensions, signs and pavement marking may be required on approaches (see Figure 10.19).

The centre blister is a horizontal displacement 'slow point' type traffic control device for use on local streets in mid-block locations away from intersections.

Noise levels may be increased due to braking and acceleration and the horizontal displacement effects of vehicles.

10.9.1. Design requirements

Some of the design principles and features of centre blisters are similar to the local street roundabout insofar as the design of the centre blister utilises the Standard Design Envelope (SDE) to determine the vehicle paths on the approaches and through the device while minimising the width of the vehicle lanes. Refer to Section 10.9.4.

Centre blisters may be used in a series along a road in accordance with [Section 10.1.1](#) or alone to reduce vehicular speeds and to discourage use by through traffic.

The location of a centre blister should not restrict access to adjacent properties, or require drivers to perform unavoidable illegal movements when accessing these properties.

The road at a centre blister must be kerbed with barrier kerb for sufficient distance on the approaches to prevent corner cutting, and to provide adequate visual guidance into the centre blister.

Semi-mountable kerb shall be used in the construction of the median and any kerb extensions. A painted median or painted kerb extension is not permitted.

Where occasional travel over the central island by a heavy vehicle may need to be accommodated, this shall be facilitated by paving that portion of the median and providing a mountable kerb. If a long vehicle such as a bus will regularly use the centre blister, it shall be designed so that the vehicle does not ride over the median or kerb extensions.

10.9.2. Construction

Once construction of the median has begun a SLOW POINT warning sign (W5-33) shall be installed on each approach.

10.9.3. Signs

A KEEP LEFT sign (R2-3L) may be installed within the median on each approach to a centre blister if it is not readily apparent under all normal driving conditions that drivers should keep to the left.

Although not generally necessary, unidirectional hazard markers (D4-1-2) may be used to increase the visibility of the median.

10.9.4. Speed control

The speed of traffic entering and negotiating a centre blister is controlled by the geometric design of the centre blister. The slow-in-faster-out performance aim is necessary in its design to ensure it will operate safely and ensure that the speed of traffic using it is kept low.

The Standard Design Envelope (SDE) in Appendix D, is used to assist the designer in producing safe and consistent geometric centre blister designs.

The function of the SDE is to position the outer edge of the median relative to the approach and exit kerbs of the centre blister to achieve a design speed of approximately 35 km/h.

For each approach the outer arc of the SDE must contact the approach and exit kerbs or kerb extensions. The inner arc must contact the median (see Figure 10.20 and 10.21). The SDE must contact only at a single point, no overlap is permitted.

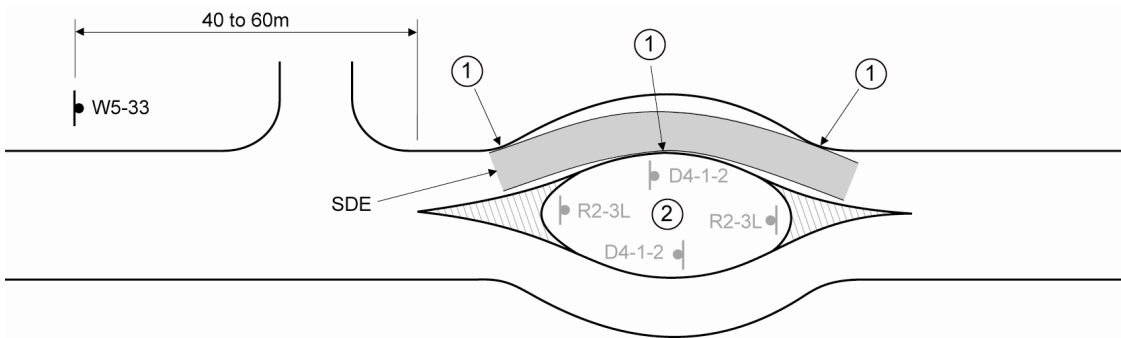

NOTE : 1 The SDE contacts on approach kerb, centre blister median kerb and exit kerb.

2 Signs are only necessary if the centre blister and its width are not readily apparent.

Figure 10.20 Centre blister on narrow roadway

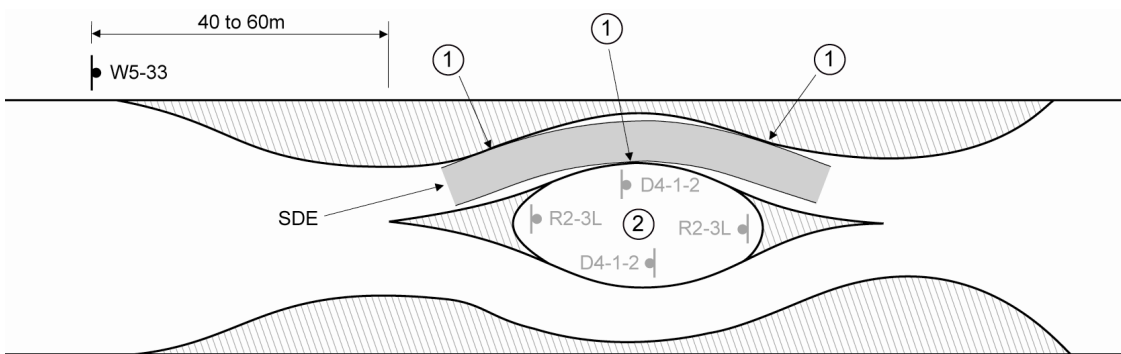

NOTE : 1 The SDE contacts on approach kerb, centre blister median kerb and exit kerb.

2 Signs are only necessary if the centre blister and its width are not readily apparent.

Figure 10.21 Centre blister with kerb extensions

10.9.4.1. Approaching traffic

A centre blister design must also reduce the speed of approaching traffic prior to the entry. The design shall prevent any portion of the vehicle path, approaching the centre blister on a straight trajectory, to pass the median without deflection. Otherwise, vehicles can enter at unacceptably high speeds, which endangers other road users and increases the risk of the driver losing control as the vehicle must reduce speed within the centre blister to exit safely.

10.9.4.2. Straight roads

For a centre blister placed on a straight section of road, the requirement in Section 10.8.4.1 is met when there is no gap between the outer edge of the median and the prolongation of the left-hand 'approach' kerb to the 'exit' kerb. A kerb extension may be required on an approach to cover up any gap (see Figure 10.21).

10.9.4.3. Curved roads

Centre blisters placed on curved roads require special attention to prevent vehicles from being able to enter the centre blister without deflecting and not having to reduce speeds. Figure 10.22 shows how the inadequate design of a centre blister on a curved road produces a gap allowing approaching vehicles to enter at potentially high speed.

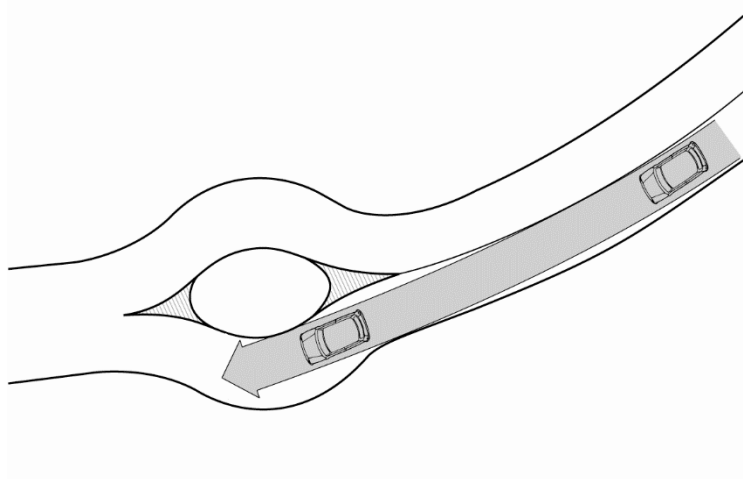

Figure 10.22 Incorrect design of centre blister on curved approach

10.9.5. Swept path

Centre blisters frequently used by long vehicles should be designed so that the vehicle's overhang does not present a hazard to pedestrians and roadside furniture on the footpath. To achieve this, the swept path of the vehicle should be completely contained within the road.

10.9.6. Entry width

The entry width is the shortest distance measured between the 'nose' of the median and the left-hand kerbline or kerb extension. The entry width should not exceed 3.5 m but may be increased for the passage of buses or large vehicles to a maximum of 4 m.

10.10. Driveway entries and links

Driveway entries and links shall be installed only in accordance with *AS 1742.13 MUTCD Part 13: Local area traffic management*, *Austrroads Guide to Traffic Management Part 8* and the variations and additions contained in this section.

10.10.1. General

The aim of driveway entries and links is to give the appearance of a closed portion of road. A driveway entry is located at an intersection or T-intersection (see Figures 10.24, 10.25 and 10.26) while a driveway link is located mid-block along a road (see Figure 10.23).

A driveway entry shall only be located at an intersection of local streets. For treatment of entrances to a local area from an arterial or sub-arterial road, refer to [Section 10.2](#) for perimeter thresholds, or [Section 10.3](#) for contrasting pavements.

The combination of landscaping, installing kerbs, and using contrasting pavement alters the road to give the appearance that the road does not continue. A semi-concealed 'driveway' located off to the side allows local access through the treatment.



Figure 10.23 Driveway link

A heavy reliance is placed on the form and depth of the landscaping to control traffic by redefining the general streetscape. This also serves to enhance the quality of the residential area.

The design principles and features between driveway entries and driveway links are similar, with the difference being where they are located.

10.10.2. Essential design elements

The design principles and features of driveway entries and driveway links are similar.

Visual impact and low vehicle speeds are the main factors that shall be present to produce an effective driveway treatment. From a distance, the treatment should look to the driver as though the road is closed, but when approached the way through should be readily discernible.

To achieve the desired visual impact and reduce speeds, the following design elements shall be present:

- (a) extensive landscaping,
- (b) a vehicle path resembling a private driveway, which is narrow, meandering, and raised above the general road level, and
- (c) an entry to the driveway treatment located on the right-hand side of the road.

10.10.3. Appearance of driveway entries

An intersection treated with a driveway entry should give the appearance of a T-intersection with a 'private driveway' located opposite the terminating leg of the new intersection (see Figure 10.24).



Figure 10.24 Driveway entry at an intersection

The geometric design of a driveway entry located on a continuing leg of a T-intersection makes the T-intersection appear as a single road with a bend in it. The driveway entry gives the appearance of a 'private driveway' entering on the outer edge of the new bend formed (see Figure 10.25).



Figure 10.25 Driveway entry at a T intersection – continuing leg

A driveway entry constructed on a terminating leg of a T-intersection should give the appearance of a single straight road with a 'private driveway' where the terminating road previously existed (see Figure 10.26).



Figure 10.26 Driveway entry at the stem of a T intersection

10.10.4. Urban design elements

The effect sought from the design of a driveway treatment is to create, using suitable landscaping, an environment that visually prevents approaching drivers from having a long distance view of the road beyond the treatment. When approaching the treatment, the landscaping should be visually and physically restrictive and uninviting to deter drivers who are not local residents of the road from entering.

Landscaping may consist of other roadside furniture items such as planter boxes, seating or artwork so long as they meet the objectives of this section.

The major role of the landscaping is achieved by selecting trees that will grow with high level foliage and slender trunks to break the long distance view of the road. While shrubs and bushes provide low level screening, it shall still allow drivers to see oncoming vehicles within or about to enter the treatment. Regular pruning to maintain the screening effect and visibility requirements may be necessary. The selection and placement of plants shall not present an unreasonable degree of hazard if struck by an errant vehicle.

The visual impact of the landscaping in a driveway treatment is an important element and plays a vital part in determining the success of the treatment. The effect sought from the planting should be achieved within 12 months and be maintained all year. Deciduous plants may not achieve this.

The total area of landscaping, excluding the adjacent footpath, should be approximately twice as much as the area of the vehicle path.

The effectiveness of the landscaping is affected by the overall length of the driveway treatment, provisions for drainage, and access to private property.

10.10.4.1. Length of treatment

The length of the treatment to achieve the landscaping requirements is determined by the width of the road, the number and location of private driveways, inclusion of on-street parking and the width of the vehicle path.

Longer treatments will more readily achieve the design aims for a driveway treatment, particularly as the trafficked areas minimise the area for landscaping.

The length of a driveway link shall be greater than 30 m while a driveway entry shall be greater than 20 m.

10.10.4.2. Drainage

To remove the visual continuity of the road produced by the original kerb and allow maximum use of the road reserve for landscaping, the existing kerb and channel on the treated section of road should be removed. Stormwater may be channelled into an underground system or drainage facilities may be incorporated into the landscaping, in accordance the principles of water sensitive urban design.



Figure 10.27 Example of drainage treatment at driveway entry

Where this is impracticable, a covered drainage channel such as a box culvert in place of the original kerb and channel, at least at each end of the treatment, is preferable to an open channel for the full length of the treatment.

10.10.4.3. Private property access

The driveway treatment should be free from private driveways to maximise the area for landscaping. If a private driveway must be integrated into a driveway treatment, an increase in both the length of the treatment and the width of the vehicle path opposite the private driveway may be required (see Figures 10.28 and 10.32).

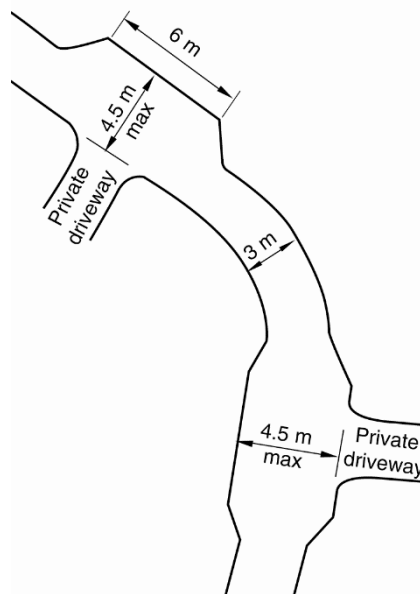

Figure 10.28 Passing areas

10.10.5. Design requirements

The function of the vehicle path is to allow vehicles through the treatment at a low speed. The design speed is 10 km/h and is achieved by a narrow, tightly meandering path over its entire length.

The design of the entrance to a driveway treatment shall ensure that the speed of traffic using it is kept low. The slow-in slow-out performance aim is necessary in the design of the entrance to ensure it will operate safely.

To maintain low vehicle speeds, driveway entries or links shall not be installed on roads with a gradient exceeding 10%, unless, in accordance with *Austrroads Guide to Traffic Management Part 8: Local Street Management (2020)* 'a comprehensive risk management assessment process is conducted and all necessary requirements are appropriately addressed'.

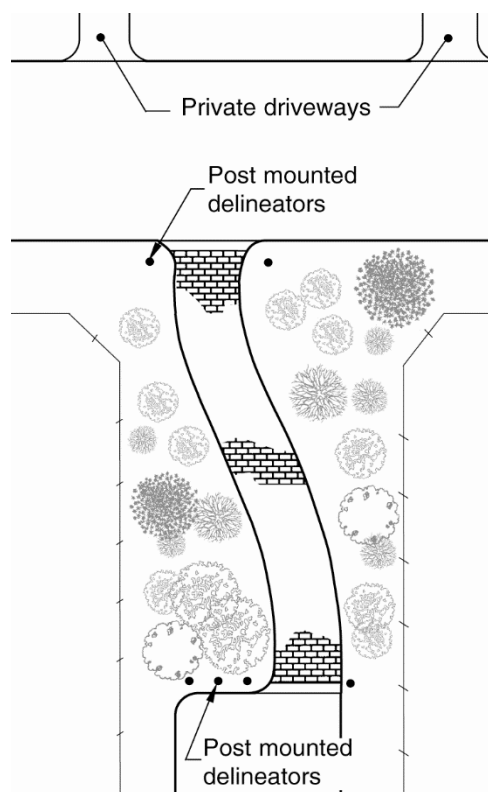

Figure 10.29 Driveway entry on stem of T-intersection

10.10.5.1. Entrance

An entrance should not exceed a width of 3.5 m. This may be increased where it is necessary to provide for the swept path of a large vehicle turning into or out of a driveway treatment, but shall be less than 5 m.

To achieve the design requirements, the entrance shall:

- (a) be located as close as possible to the right-hand edge of the road;

- (b) be located completely within the right-hand side of the road;
- (c) be perpendicular to the centre line of the road so that vehicles cross it at right angles; and
- (d) have a mountable kerb and tray where the vehicle path is raised (see Section 10.10.6).

The location of the entrance to a driveway entry located on a continuing leg of a T-intersection shall, besides that stated previously, be:

- (a) within the former T-intersection; and
- (b) on the outer boundary of the new bend formed (see Figure 10.30).

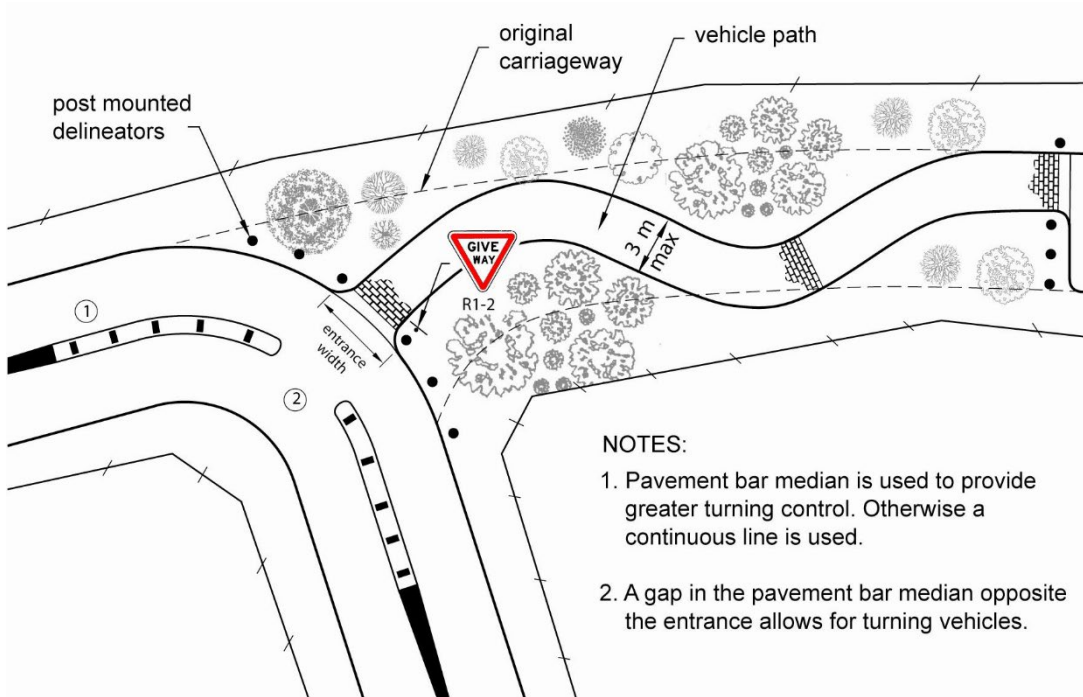

Figure 10.30 Driveway entry on continuing leg of T-intersection

A driveway link, or end of a driveway entry, should be located away from side roads to avoid queued vehicles blocking the side road. A minimum setback from a side road should be equivalent to the longest queue length likely to be encountered or a minimum of 8 m whichever is greater (see Figure 10.31).

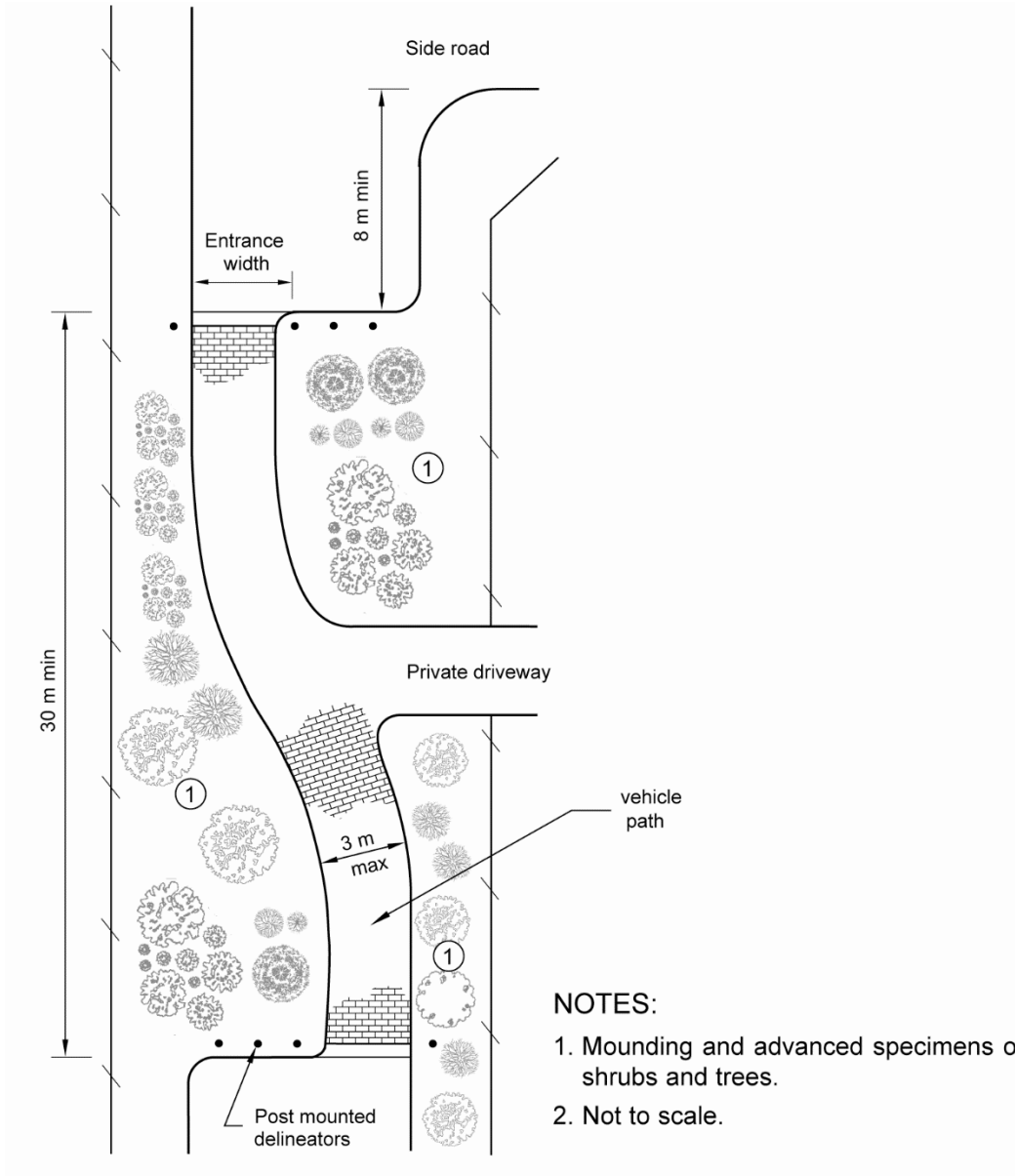
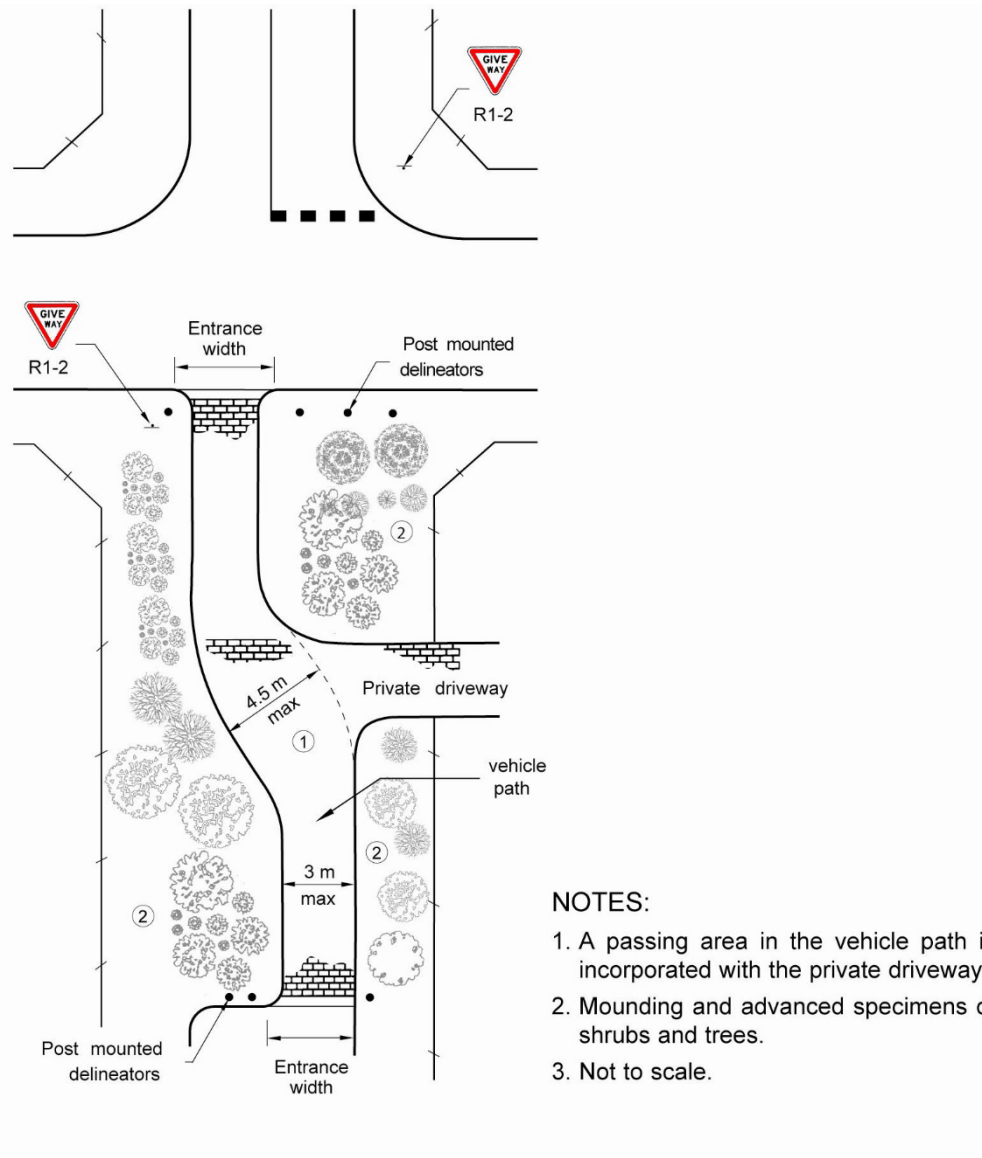

Figure 10.31 Driveway link



- NOTES:
1. A passing area in the vehicle path is incorporated with the private driveway.
 2. Mounding and advanced specimens of shrubs and trees.
 3. Not to scale.

Figure 10.32 Driveway entry at an intersection

10.10.5.2. Width of vehicle path

An important aspect to consider when deciding the width of the vehicle path is that commercial vehicles are generally no wider than 2.5 m. Therefore the vehicle path need not be much wider than the largest vehicle likely to regularly use the road such as the council garbage truck. The maximum width is 3 m unless the length of the treatment, generally greater than 80 m, requires a passing area (see Figures 10.28 and 10.32).

A minimum width is deliberately not prescribed as it is conceivable that in some situations where all commercial vehicles are prohibited from the road, a vehicle path of less than 2.5 m is permitted and indeed preferred.

10.10.6. Construction

The vehicle path surface shall be constructed in a material contrasting in colour and/or texture with that of the road, (e.g. concrete block paving) and should be raised 100 mm above the existing road surface. This height may be reduced or eliminated, where the 85th percentile speed of vehicles on approach to the driveway treatment, is less than 40 km/h.

The driveway treatment shall extend across the full width of the road using barrier or semi-mountable kerb.

Entrances may be constructed with a mountable kerb and tray as shown in Figure 10.33. Another kerb may be used provided its effect on vehicles is not greater than the kerb specified.

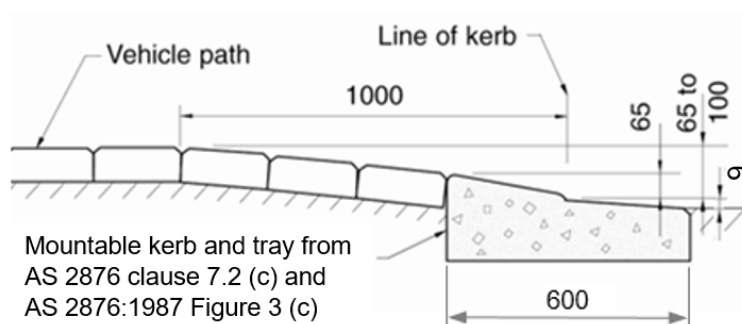

Notes:

- 1) For vehicle path heights less than 65 mm the gradient of the kerb is reduced so that the top of kerb is level with the top of the vehicle path.
- 2) Not to scale

Figure 10.33 Mountable kerb detail

10.10.7. Signs and delineation

A GIVE WAY sign (R1-2) or STOP sign (R1-1) shall not be used at a driveway link or driveway entry unless at an intersection (see Figures 10.30 and 10.32).

The aesthetics of a driveway treatment are an important aspect in creating a low speed environment. The intention of the narrow vehicle path and extensive landscaping is to create the appearance of a private driveway, and the use of warning signs and hazard markers may counteract this effect.

The SLOW POINT (W5-33) sign with ONE LANE (W8-16) supplementary sign shown in *AS 1742.13 MUTCD Part 13: Local area traffic management* should only be used where the device may not be visible to approaching drivers at prevailing traffic speeds.

Post mounted delineators, consisting of frangible or flexible posts with retroreflective devices permanently attached may be provided at the entrances to driveway links or driveway entries to improve night time delineation of the device (see Figures 10.29, 10.30, 10.31 and 10.32). Unidirectional hazard markers may be used if additional delineation is required.

10.10.8. Pavement markings

At a driveway entry located on a continuing leg of a T-intersection, a continuous dividing line or pavement bar median shall be marked around the new bend formed (see Figure 10.30). A gap in the pavement bar median shall be provided opposite the entrance to allow for turning vehicles.

10.11. T-intersection re-arrangement

T-intersection re-arrangements (modified T-intersections **with** change in priority) shall be installed in accordance with *AS 1742.13 MUTCD Part 13: Local Area Traffic Management* and *Austrroads Guide to Traffic Management Part 8*. Additional guidance is also provided in *AS 1742.2 MUTCD Part 2: Traffic Control Devices for General Use (2022)* Section 2.9.7 and Appendix C, and the variations in [Section 5.3](#) of this document.

T-intersection re-arrangements (modified T-intersections **without** change in priority) shall be installed only in accordance with the *Austrroads Guide to Traffic Management Part 8* and the variations and additions contained in this section.



Figure 10.34 Modified T-intersection without change in priority
(Valiant Rd / Southern Tce, Holden Hill)



Figure 10.35 Modified T-intersection without change in priority
(Morgan St / Watkin St, Parafield Gardens)
(Image from GoogleMaps "Street View")



Figure 10.36 Modified T-intersection without change in priority
(Collins Parade / Susan Road, Hackham)
(Image from GoogleMaps "Street View")

Modified T-intersections without a change in priority are used to slow traffic via a horizontal deflection of traffic movement similar to a slow point, but located at a T-intersection.

The speed of vehicles negotiating the T-intersection is governed by its geometric design. The Standard Design Envelope (SDE) contained in [Appendix D](#) is typically used for the geometric design to produce a safe, consistent and effective design consistent with the design speed of other horizontal deflection devices.

Modified T-intersections without a change in priority may be used in series with other devices such as slow points, or in isolation as a localised traffic calming device. As such, variations to the design envelope and the associated design speed may be used to achieve the desired outcome. This must be documented in the traffic impact statement for the treatment, including the reasons for the selection of the design speed and the risks associated with it. Figures 10.34, 10.35 and 10.36 are examples of various designs of this type of device.

The following signs and line marking should be used with this device where appropriate:

- Give Way (R1-2) sign and pavement marking to indicate to vehicles on the terminating leg where to hold, while providing clearance to the through vehicles. The Give Way line will also assist in delineating the travel path for through vehicles
- Continuity line in accordance with the *DIT Pavement Marking Manual* (<http://www.dit.sa.gov.au/?a=40257>)
- Slow Point (W5-33) signs, particularly where the device is installed in isolation
- Keep Left (R2-3 or R2-SA3) signs on raised medians
- Hazard marker (D4-1-2) on the kerb extension
- Where it is impractical to provide a raised median and kerb extension, painted medians and islands, supplemented with pavement bars (or RRPMS in accordance with the *DIT Pavement Marking Manual* (<http://www.dit.sa.gov.au/?a=40257>)) may be used.

Landscaping and vegetation at the intersection must not obstruct sight lines, particularly as the position where drivers on the terminating leg hold to give way may alter as part of the T-intersection re-arrangement.

11. Off-street traffic control

11.1. General

Requirements for the following devices in off-street areas are specified in this Code:

- Roundabouts in off-street areas (See Appendix C4 for requirements for roundabouts in off-street areas).
- Pedestrian crossings in off-street areas (See the Off-street Zebra and Off-street Wombat Crossing clauses in DIT's [Supplement to AS 1742.10](http://www.dit.sa.gov.au/?a=1229509) (www.dit.sa.gov.au/?a=1229509)).
- Road humps and road cushions in off-street areas (See [Section 10.6.4](#) for requirements for road humps and road cushions in off-street areas).

Other traffic control devices specified in the Australian Standards, except those prohibited by the Code, may be used in off-street areas.

All traffic control devices in off-street areas shall comply with the requirements of the Code, including the requirement to obtain separate approval from the Commissioner of Highways or authorised delegate for the use of any of the devices listed in [Appendix A](#). In particular, speed limits in off-street areas shall only be used with separate approval from the Commissioner of Highways or authorised delegate. Refer to the *Speed Limit Guideline for South Australia* for details of appropriate speed limits for off-street areas.

11.2. Stop and Give Way signs at access driveways

AS/NZS 2890.1 Parking facilities Part 1: Off-street car parking (2004) clause 4.3.4(b) states that GIVE WAY and STOP signs are normally required where an access driveway meets a frontage roadway. They shall only be installed where an access driveway meets a frontage roadway and the requirements of *AS 1742.2 MUTCD Part 2: Traffic control devices for general use* and this document are met.

Where an access driveway has been constructed in such a way that it may appear to road users to be an intersection of two roads rather than an access driveway meeting a road, a GIVE WAY sign may be installed to promote the priority for pedestrians crossing this driveway. This situation may occur where the driveway is at the same level as the road, is constructed from the same material as the adjoining road and has kerb ramps where the footpath meets the driveway. In this case, the GIVE WAY sign should be located before the kerb ramps as drivers exit the driveway, so that drivers give way to pedestrians at this point.

12. Traffic control at works on roads

12.1. General

Traffic control devices at works on roads shall comply with DIT's [SA Standards for Workzone Traffic Management](http://www.dit.sa.gov.au/?a=316525). (www.dit.sa.gov.au/?a=316525)

12.2. Speed limits at works on roads

Speed controls at works on roads shall comply with DIT's [SA Standards for Workzone Traffic Management](http://www.dit.sa.gov.au/?a=316525). (www.dit.sa.gov.au/?a=316525)

Appendix A: Traffic control devices requiring separate approval

The devices listed below require approval from the Commissioner of Highways or authorised delegate for their use.

[Section 1.4](#) of this Code contains further details on the legal framework, approval process for traffic control devices in accordance with the Instruments, and the preparation of Traffic Impact Statements.

NOTE: The Austroads *Guide to Road Design Part 7: New and Emerging Treatments (2020)* contains innovative treatments which are yet to be included in other parts of the Guides. These treatments are considered to be non-standard and shall only be used on a trial basis subject to consultation with DIT and the appropriate approvals for traffic control devices under the *Road Traffic Act 1961* (see [Section 1.4.2](#)).

A1. Signs

Regulatory Signs

R2-15	U-turn permitted
R2-20	Left turn on red permitted after stopping
R2-21	Right turn from left only
R2-22	No hook turn by bicycles
R2-SA61	Right turn from left lane only Adelaide Metro Buses
R2-SA62	Right turn from left lane only Adelaide Metro Buses with times
R3-2	Safety zone
R3-5	Pedestrians may cross diagonally
R4 series	Speed limit signs except: <ul style="list-style-type: none"> • at works on roads (refer Section 12.2) • School zones (refer <i>Speed Limit Guideline for South Australia</i>) • Wombat crossings (refer <i>Supplement to AS 1742.10</i>) • Koala crossings (refer <i>Supplement to AS 1742.10</i>)
R5-58	Emergency stopping lane
R5-50	Clearway (start)
R5-51	End clearway
R6-13	No pedestrians beyond this point
R6-18	Buses must enter
R6-19	Start freeway
R6-20	Freeway entrance
R6-21	End freeway
R6-27	Trucks must enter

R6-28	Trucks use left lane
R6-29	Keep left unless overtaking
R6-30	Median turning lane
R6-32	End keep left unless overtaking
R6-SA103	End no wheeled recreational devices (Skaters permitted)
R6-SA104	No wheeled recreational devices (All skaters prohibited)
R7-1-1	Bus Lane
R7-1-3	Truck Lane
R7-1-5	Tram Lane
R7-1-6	Bus, bicycle lane
R7-7 series	Transit lane signs
R7-9 series	End transit lane signs
R7-8	Bus only
R7-10	Tram only
R9-SA106	over xx.x t
R9-SA107	On green arrow
R9-19	Give Way If Going Straight Ahead

Guide Signs

G9-10	Slow vehicle lane ahead
G9-11	Slow vehicle lane 1km ahead
G9-12	Slow vehicles use left lane
G9-46	Very steep climb not suitable for ...
G9-47	Very steep climb next x kms
G9-17	Winding road ends x km
G9-67-2AA	Keep Tracks Clear (small size)
G9-79	Speed limit ahead
GE9-22-1	Lane ends merge right
GE6-9	End freeway
GE6-10	End freeway 1 km
GE9-3	Reduce speed now
GE6-2	Prohibited on freeway, pedestrians etc
GE2-3	Exit

Signs for temporary purposes

R6-8 / T7-1	Stop / Slow Bat when used for the purpose of an event under Clause E of the <i>Instrument of General Approval to Council</i> . Stop / Slow Bat operators must carry evidence certifying current accreditation in the appropriate DIT approved Temporary Traffic Management training qualification, in the form of Workzone Traffic Management card issued by DIT.
-------------	---

Other signs

Any signs listed as requiring approval of the Manager, Traffic Services on the DIT Sign Index (<https://signindex.dit.sa.gov.au/signs>)

A2. Pavement markings

Bus lane markings

All skaters prohibited (No wheeled recreational devices)

Wide dividing line treatment

A3. Traffic signals

Scramble pedestrian crossings

A4. LATM devices

Type 1 and 2 road humps and associated pavement markings specified in *AS 2890.1*

Appendix B: Emergency services traffic signal details

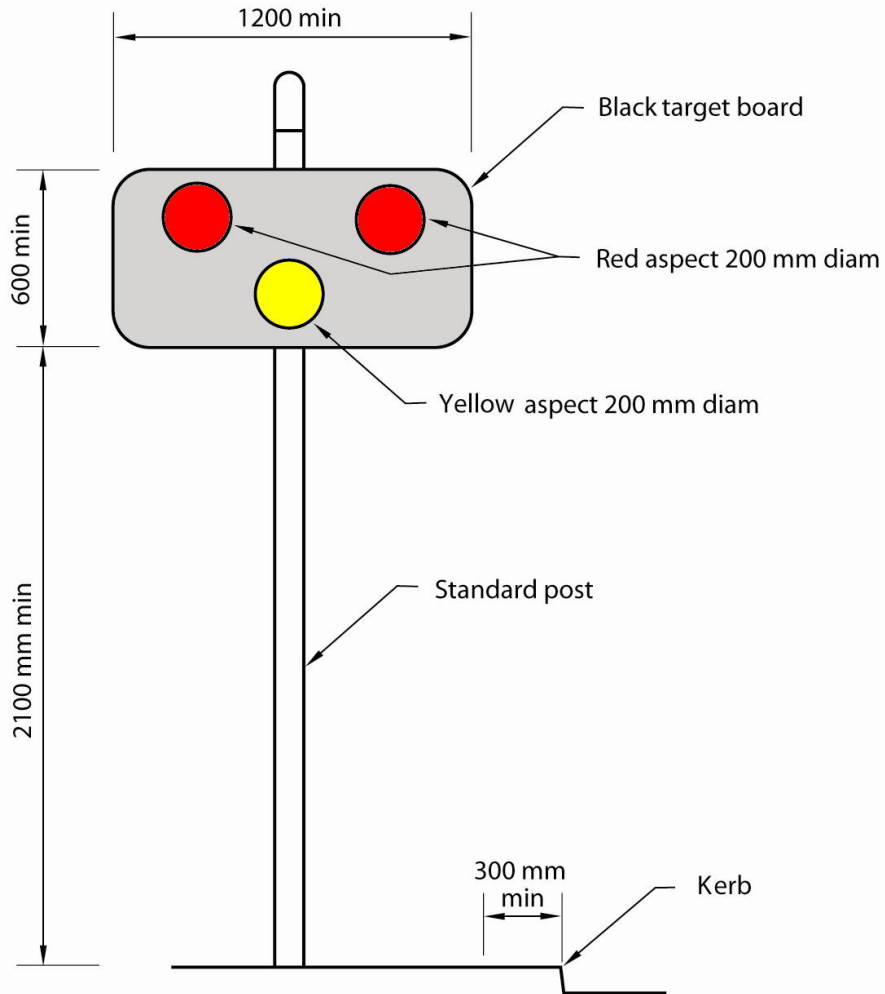

NOTES:
All aspects use standard louvres

Appendix C: Local Street Roundabouts

Local street (refer [Section 1.3](#) Definitions) roundabouts are generally located on low speed roads in areas which are primarily residential, but may also be used within commercial or business precincts.

C1. General design requirements

The central island should, where practicable, be circular in plan. Where the central island is not circular, ideally the ratio between the longer and shorter dimensions should be 4:3 or less with the smaller radius being 3.5 m or greater.

Splitter islands should be provided on each approach to deter wrong way movements by right turning vehicles. Fully kerbed splitter islands are preferred, but if this is impracticable due to essential property access requirements or it is in a narrow road, a painted splitter island may be used. Where the speed environment is 60 km/h or less, a painted splitter island should be supplemented with pavement bars.

The circulating lane of a roundabout and its immediate approaches and exits should be free from driveways accessing properties where their presence would, under normal operation, result in unavoidable illegal movements within the roundabout.

C1.1. Design vehicle considerations

If there is a possibility of long vehicles riding over the central island, that portion of the central island should be paved. If the roundabout is located on a bus route, or subject to regular use by long vehicles, it should be designed so the vehicle does not ride over the central island. Emergency services requirements should also be considered.

Roundabouts frequently used by long vehicles should be designed so that the vehicle's swept path does not present a hazard to pedestrians or road furniture. To achieve this, the swept path of the vehicle should be completely contained within the road. Where occasional travel over the central island by a heavy vehicle may need to be accommodated, this shall be facilitated by a 40 mm high mountable kerb. Any necessary signs shall be located clear of this area.

C1.2. Entry width

The entry width is the shortest distance between the outer edge of the splitter island to the corner kerb or kerb extension prior to the give way line. It should not exceed 3.5 m but may be increased for the passage of buses or large vehicles to a maximum of 4 m.

C1.3. Kerb

The full length of each corner curve at a roundabout should be kerbed for sufficient distance on the approach to each corner to prevent corner cutting and to provide adequate visual guidance into the roundabout. A barrier kerb should be used.

Barrier kerb should not be used in the construction of central islands, raised splitter islands and kerb extensions.

C2. Speed control

The speed of traffic entering and within a roundabout is controlled by the geometric design of the roundabout. A design tool referred to as a Standard Design Envelope (SDE) has been developed to assist the designer in producing safe and consistent geometric roundabout designs. The SDE consists of two concentric arcs with an outer radius of 36 m and an inner radius of 34 m. The function of the SDE is to position the central island relative to the other components of the roundabout for a design speed of approximately 35 km/h. A 1:200 scale SDE is included in Appendix D.

C2.1. Through traffic

For each approach to a roundabout, the outer arc of the SDE shall contact the corner kerbs or kerb extensions and the inner arc shall contact the central island (see Figure C1). The SDE shall contact at a single point at each location.

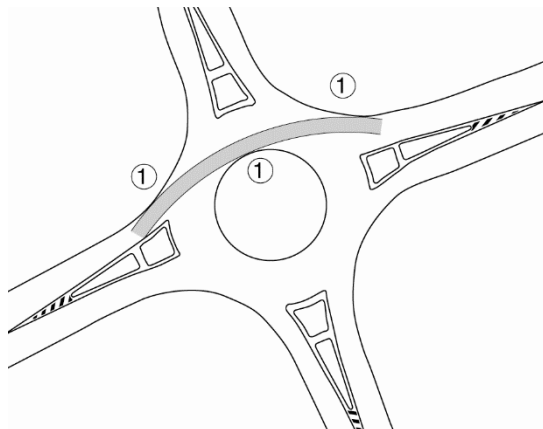

NOTE:

1. The SDE touches the corner kerbs and central island for all approaches.

Figure C1 Local street roundabout design for through traffic

For geometrically constrained intersections such as Y-intersections or where roads meet obliquely, it is acceptable to use the SDE by an alternative method. In these circumstances the outer arc of the SDE contacts the leading edge of the splitter

island and the central island, and the inner arc contacts the kerb extension (see Figure C2).

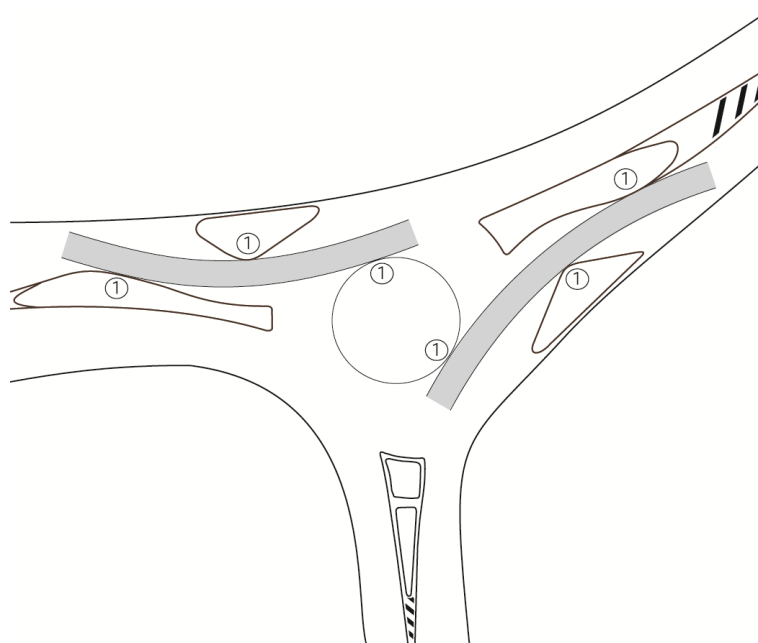

NOTE:

1. The SDE touches the splitter island, kerb extension and central island

Figure C2 Local street roundabout design for geometrically constrained intersections

The only exception where the SDE can overlap the central island is when an existing intersection is large enough to meet all other conditions of this section without altering any corner kerbs. In these cases, the amount of overlap shall be minimised, be not greater than 1 m and be approximately the same for all approaches to the roundabout to produce a consistent degree of speed control for each approach.

C2.2. Left turn traffic

Speed control at roundabouts is also important for traffic turning left. Generally, left turning vehicles are constrained to low speeds due to the geometric design of the roundabout. Higher speeds can occur where there is a large corner radius, or where roads meet obliquely such as at Y-intersections. At these sites, left turn speeds shall be limited by restricting the maximum turn radius. The SDE, when oriented as a left-hand curve (see Figure C3), defines the maximum turn radius when:

- (a) the outer arc contacts the splitter island, median or dividing line at the approach and exit of the roundabout at a single point; and
- (b) the inner arc contacts the kerb or kerb extension at a single point.

Contact with the central island is not a necessary requirement for this component of the design.

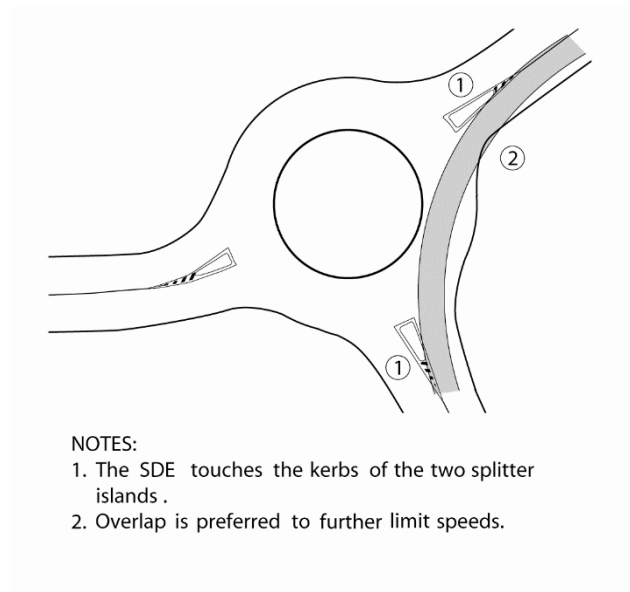

Figure C3 Local street roundabout design for left turn traffic

C2.3. Approaching traffic

A roundabout design shall also reduce the speed of approaching traffic prior to the entry. The design shall prevent any portion of the vehicle path, approaching the roundabout on a straight or near straight trajectory, to pass the central island without deflection. Otherwise, vehicles can enter the circulating lane at unacceptably high speeds, requiring them to reduce their speed within the roundabout to exit safely. This endangers other users of the roundabout and increases the risk of the vehicle losing control.

On straight approaches, the above requirement is met when there is no gap between the central island and the prolongation of the approach kerb across the side road. A kerb extension may be used on an approach to bridge this gap (see Figure C4).



Figure C4 Local street roundabout design – use of kerb extensions

On curved approaches special attention is required to prevent vehicles from entering the roundabout without having to reduce speeds. Figure C5 shows how the inadequate design of the roundabout produces a gap allowing approaching vehicles to enter at high speed.

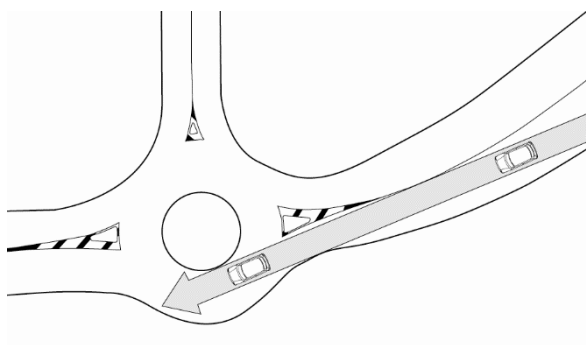

Figure C5 Inadequate design for a curved approach

C3. Small diameter roundabouts

A small diameter roundabout (as referred to in *AS 1742.13 MUTCD Part 13: Local area traffic management*) should have a circular central island with a diameter of between 4 metres and 6 metres. Smaller diameter roundabouts may lack the physical presence and visual impact to achieve appropriate driver behaviour and compliance with the road rules.

C3.1. General design requirements

The Standard Design Envelope (see Appendix D) should also be applied to small diameter roundabout design in the same way as a local street roundabout.

Alternatively, the SDE may be applied to the entry geometry of the roundabout by the outer arc of the SDE contacting the splitter island and central island, and the inner arc contacting the corner kerb or kerb extension.

There should be no clear line of sight between the left kerb alignment and the central island. A gap of not more than 1 metre is generally permissible providing it is kept to a minimum and consistent on all approaches.

The wheel path of passenger vehicles should be contained within the carriageway of the circulating lane, particularly for turning vehicles. The entry width to the circulating lane should be in accordance with the local street roundabout design requirements.

C3.2. Kerb type and construction

All splitter islands and the central island should be constructed in a mountable kerb. Kerb extensions and corner kerbs should be constructed in 150 mm high barrier kerb. The central island and splitter islands should be fully paved.

C3.3. Signs

Signs shall be installed in accordance with *AS 1742.13 MUTCD Part 13: Local area traffic management* and [Section 7](#) of this document. The 'roundabout ahead' (W2 7) warning sign should not be used unless visibility of the roundabout is poor.

C4. Off-street roundabouts

A roundabout in an off-street area should be designed to suit the speed environment, with consideration to the principles in this Appendix.

Appendix D: Standard Design Envelope

